



1718 W. Fullerton Chicago, IL 60614  
 Ph: 773.770.1195 • Fax: 773.935.5613  
 www.PureEdgeLighting.com • info@PureEdgeLighting.com  
 © 2016 PureEdge Lighting. All Rights Reserved.

## Installation Instructions for **Verge Wall 24VDC**

VG-\_-\_-

### IMPORTANT INFORMATION

- This instruction shows a typical installation.
- It is recommended more than one person assist in this installation.

**SAVE THESE INSTRUCTIONS!**



## Section One: Install the Remote Power Supply

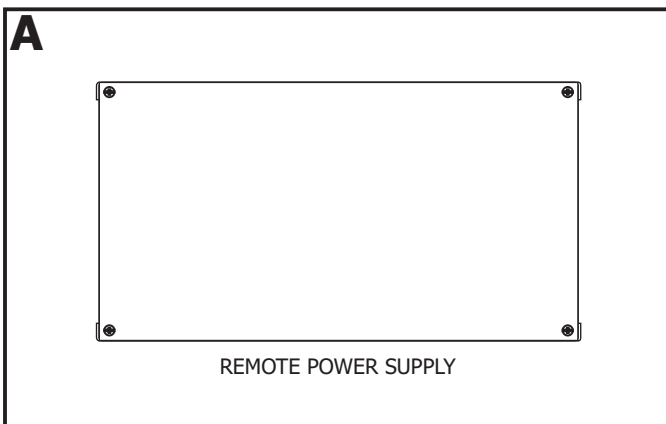

**1:** Remote power supplies must be installed within 40ft of the junction box. Refer to the instructions and wiring diagram provided with the remote power supplies.

## Section Two: Install the Junction Box

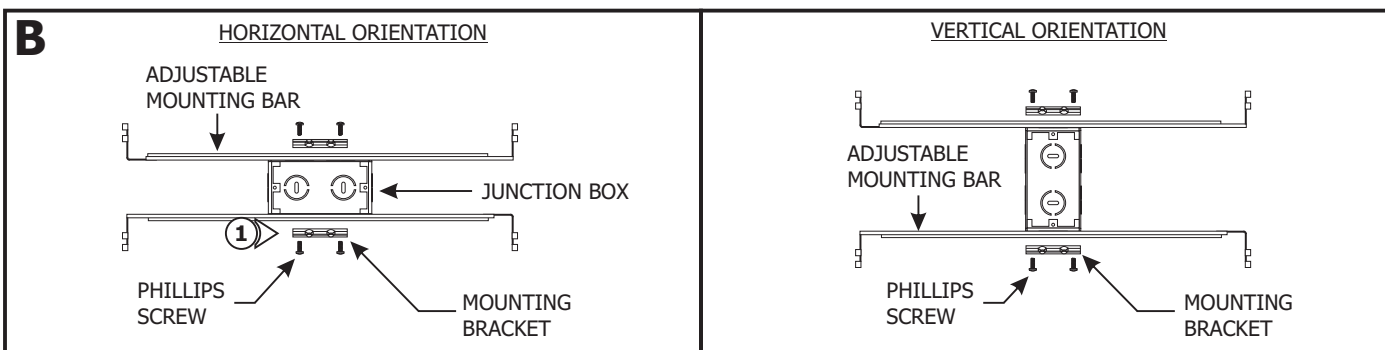

**NOTE:** The adjustable mounting bars mount to studs that are spaced 13" to 24" apart.

**1:** Mount each adjustable mounting bar to one side of the junction box (mounts to any side of the housing depending on the orientation of the channel) and secure them with the mounting brackets and two Phillips screws provided.

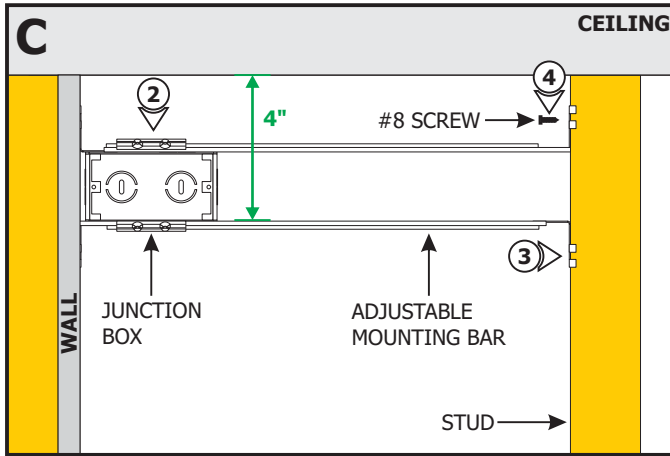

**NOTE:** junction box must be installed at least 4" from the wall when using the provided back plate.

**2:** Select the location between the two studs for the junction box to be mounted.

**3:** Place the adjustable mounting bars between the studs.

**4:** Make sure the lips on the adjustable mounting bars are against the studs. Secure the adjustable bars to the studs with the #8 screws.

**5:** Cut the drywall 4-1/8" from the ceiling (or adjacent wall.)

**6:** Mount the drywall to the studs. Mark the stud locations on the drywall for reference.

**NOTE:** For areas with lots of vibrations, use shim wood behind drywall and against studs as cross braces, or install 2x4 cross brace supports behind the drywall as needed (suggested spacing is 32") to avoid cracking of plaster. Mark the cross brace supports locations to the drywall for reference.

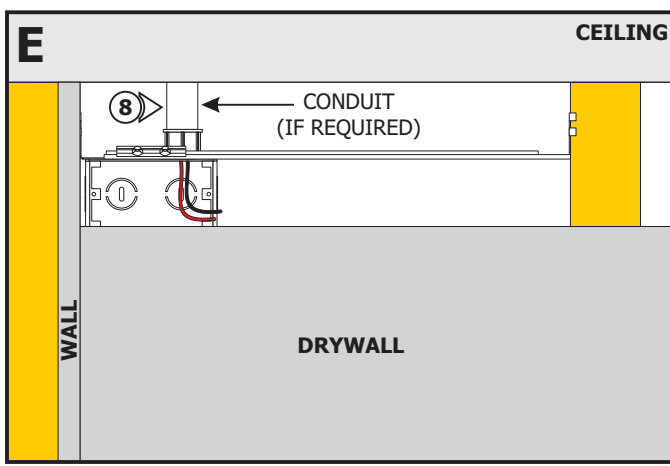
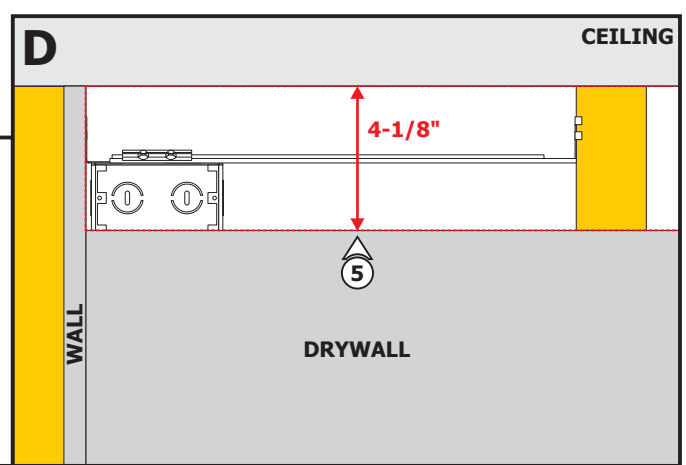

**7:** Remove a knockout to install the power line conduit.

**8:** Install the conduit (if required by local electrical codes) and run the low voltage 24VDC power wires coming from the remote power supply to the junction box.

**9:** Refer to the instruction provided with the power supply along with the wiring diagram for proper wiring.

**NOTE:** If installation requires RGB, RGB+W, or Tunable White, refer to wiring diagrams on pages 7 and 8.

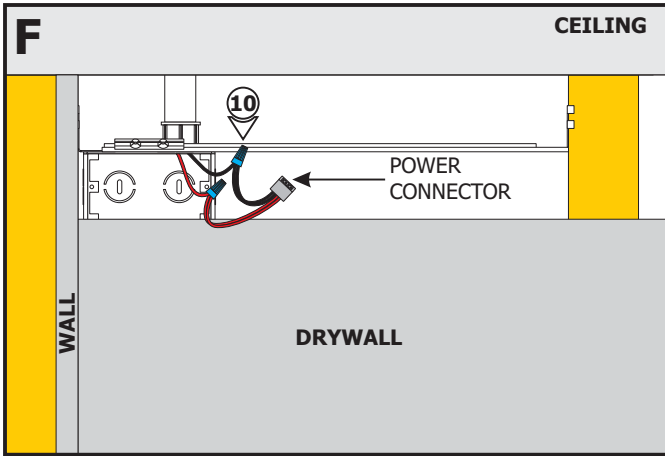

**10:** Connect the +24VDC power supply wire to the red power connector wires using a wire nut. Connect the -24VDC power supply wire to the black power connector wires using a wire nut.

**11:** Place the wire nut connections into the junction box, leaving the power connector free.

**CAUTION:** Unroll the entire LED strip from the reel and use the power connector to power the strip making sure there is no outage before continuing with the installation. Afterwards, carefully roll the LED strip loosely back into the reel.

### Section Three: Install the Backer Plate and Channel

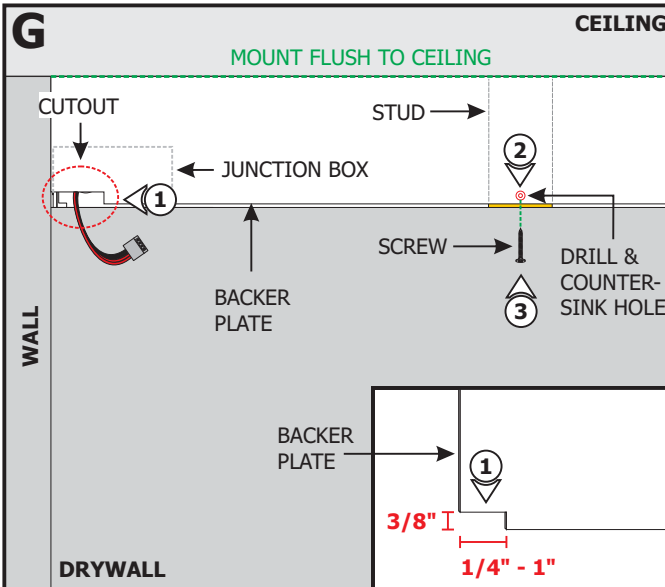

**CAUTION!** It may be necessary to remove material from the stud, backer plate, Verge channel, or lens to route power to the installation. Consult installation design when considering routing power.

**1:** Use a Dremel or other appropriate tool to make a 1/4" to 1" x 3/8" cutout on the backer plate that will be placed over the junction box.

**2:** Using the marked locations on the drywall, carefully make holes to the backer plate using the provided square drill with counter sink bit. Ensure the top edge of the backer plate is flush with the ceiling or wall.

**3:** Secure the backer plate to the studs with the #6 screws using the provided square recess bit.

**4:** Apply caulk or plaster to the backer plate to cover seams, and then paint the backer plate. For best results, use matte paint for finishing the backer plate.

**CAUTION!** It may be necessary to remove material from the stud, backer plate, Verge channel, or lens to route power to the installation. Consult installation design when considering routing power.

**5:** Use a Dremel or other appropriate tool to cut away a 1/4" to 1" section of the channel that will be placed over the electrical access junction box.

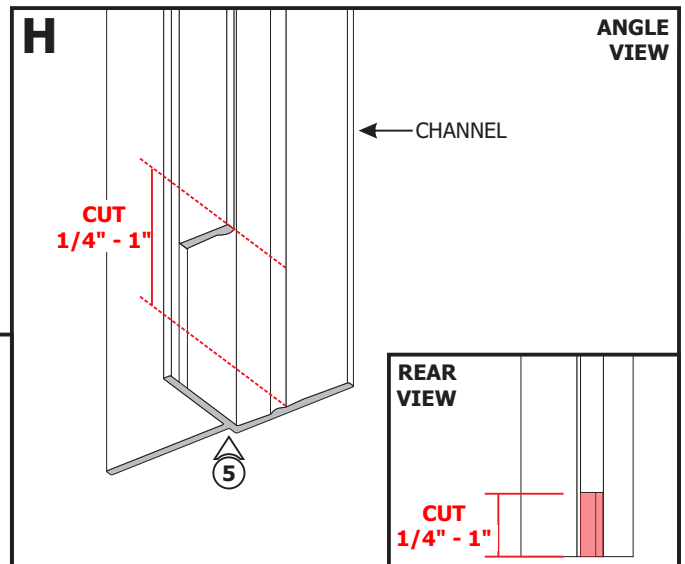

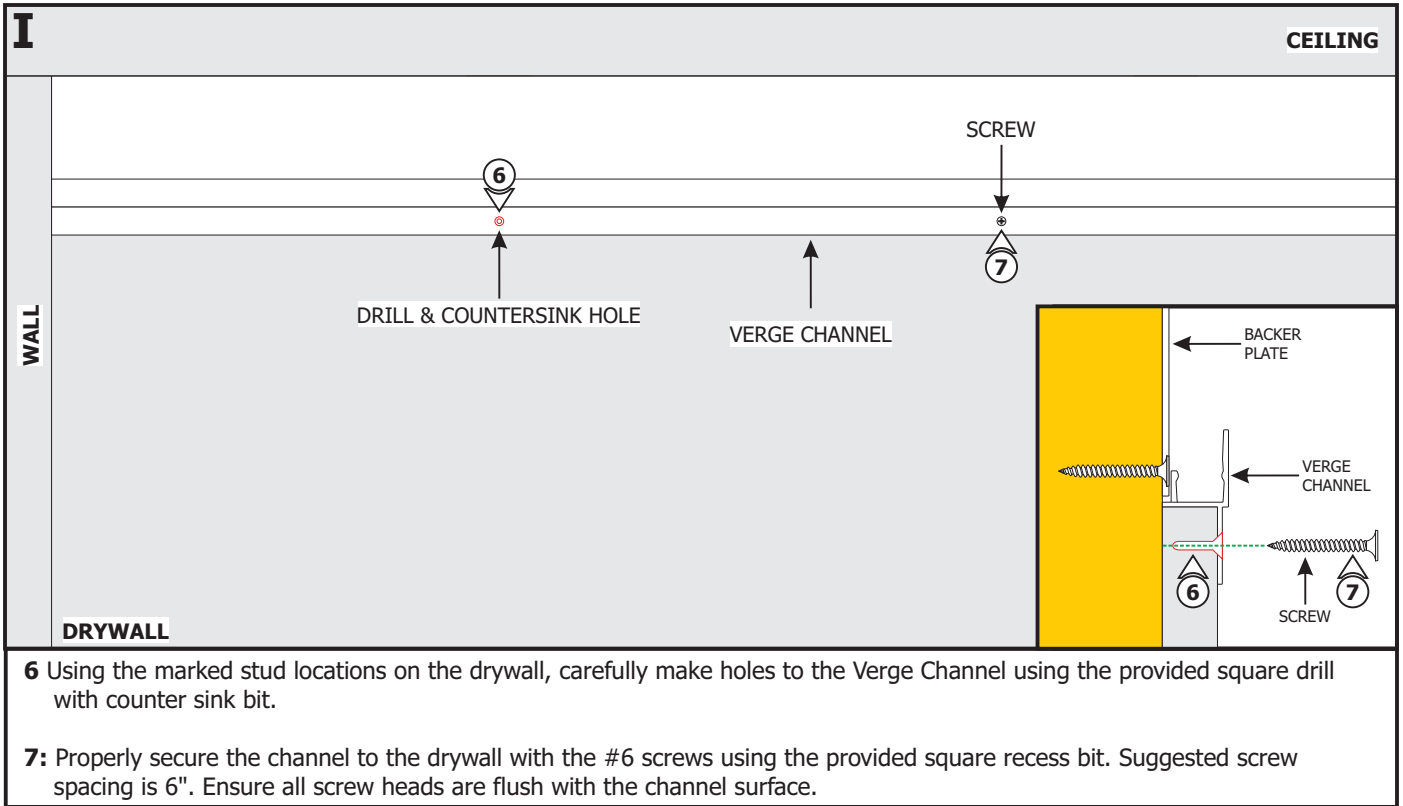

## Section Four: Plaster, Sand and Paint

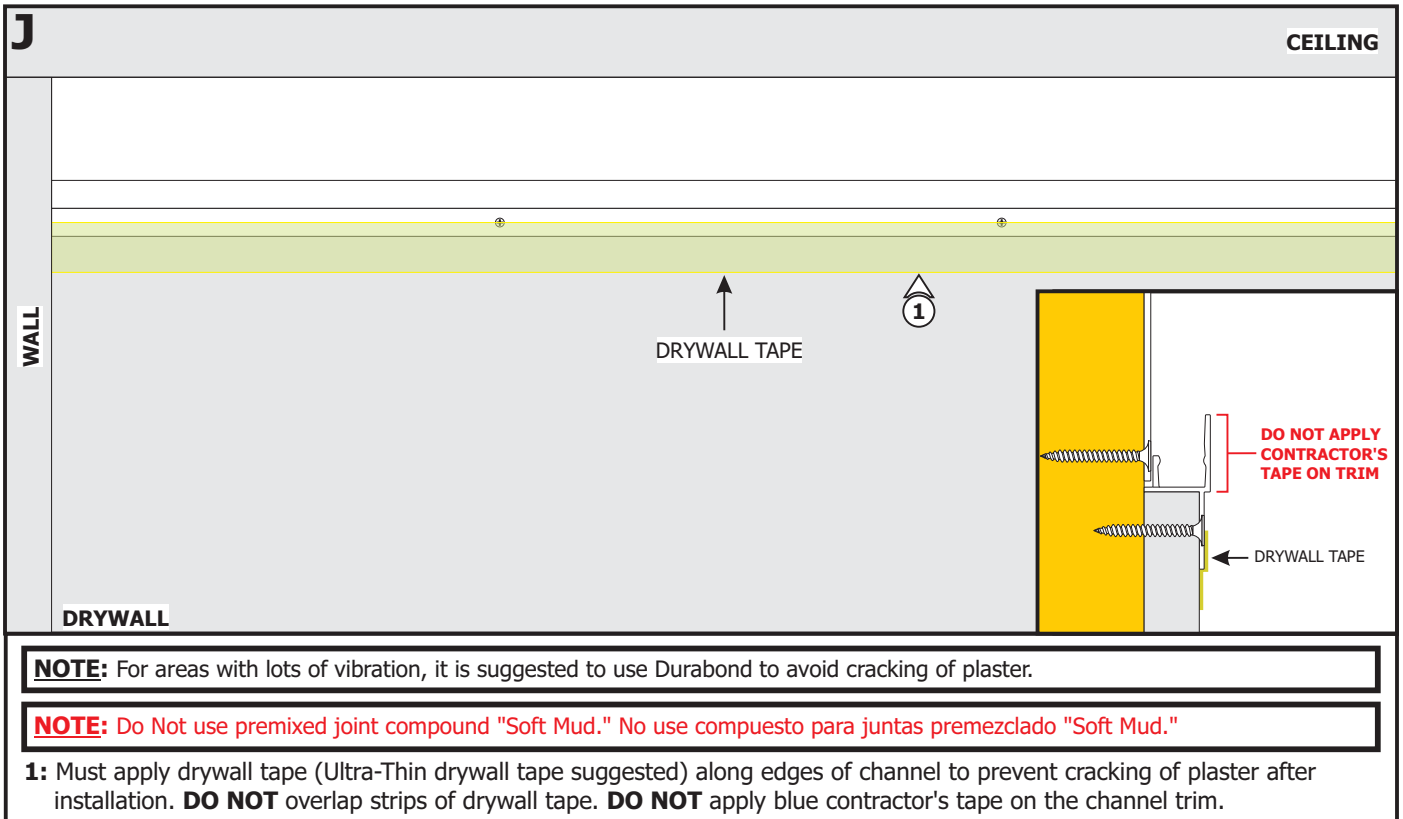

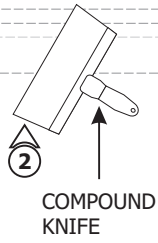
**K****CEILING****WALL**

COMPOUND KNIFE

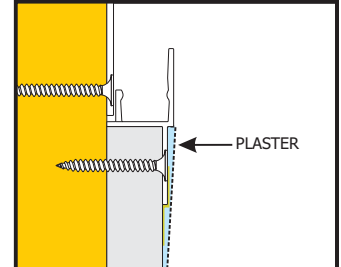

**NOTE:** Recommended plaster method: 1st Coat - Durabond 25 with 8" Blade, 2nd Coat - Easy Sand 45 with 10" Blade, 3rd Coat - with 12" blade. Taper the plaster to blend with the drywall.

**2:** Use a compound knife for a smooth compound spread. Plaster the channel flange edges to the wall & fill the screw holes.

**L****CEILING****WALL**

HAND SANDER

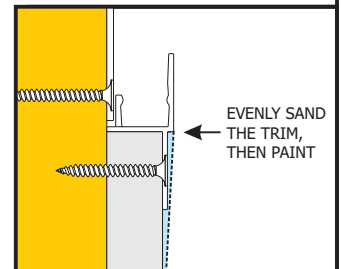

**3:** Evenly sand the plaster so that there are no seams and then paint the wall.

**4:** Clean the inside of the channel surface with alcohol to remove any dust or debris before continuing.

## Section Five: Install the LED Strip

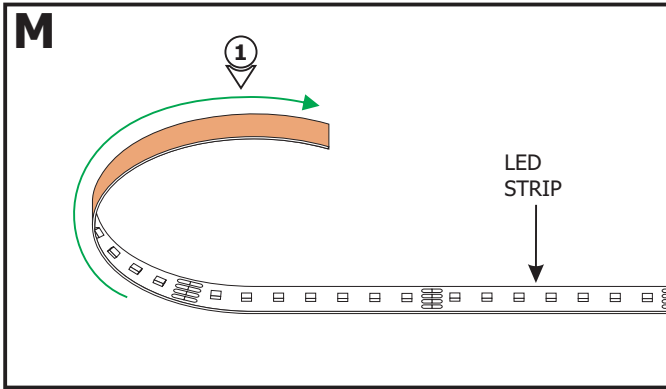

**IMPORTANT:** LED strip may not properly adhere to channel surface unless the channel is cleaned with alcohol prior to application.

**1:** Gently uncoil the LED strip before applying to the channel otherwise the strip may lift off of the surface.

**2:** Align the red wire side of the power connector with the "+24VDC" marking on the LED strip. Push the pins of the LED strip into the power connector.

**3:** Carefully remove the backing from the LED strip, making sure not to remove the tape from the LED strip. Firmly press down the adhesive portion of the LED strip onto the channel surface while removing the rest of the backing, making sure there are no air bubbles that can cause surface irregularities.

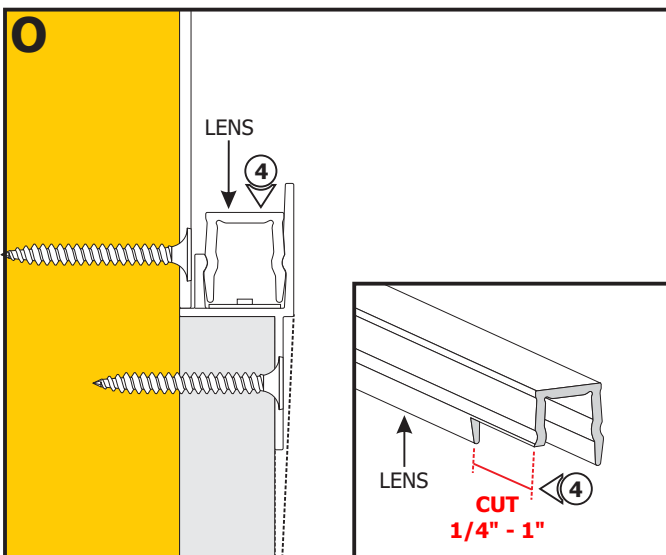
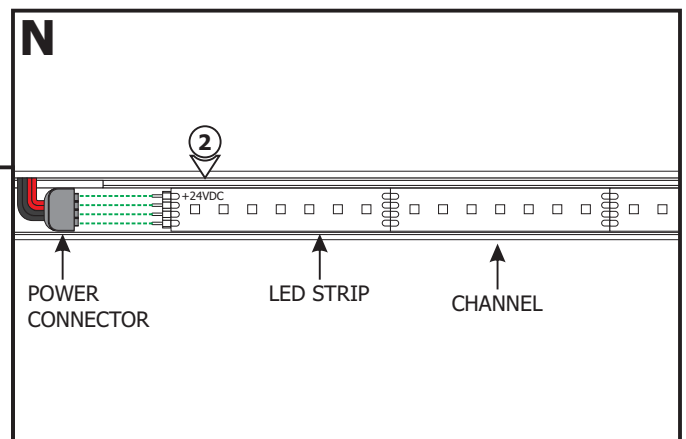

**4:** If necessary, remove material from the lens to allow room for the power connection. Snap the lens into the channel. Ensure the lens is fully seated.

# General Wiring Diagrams

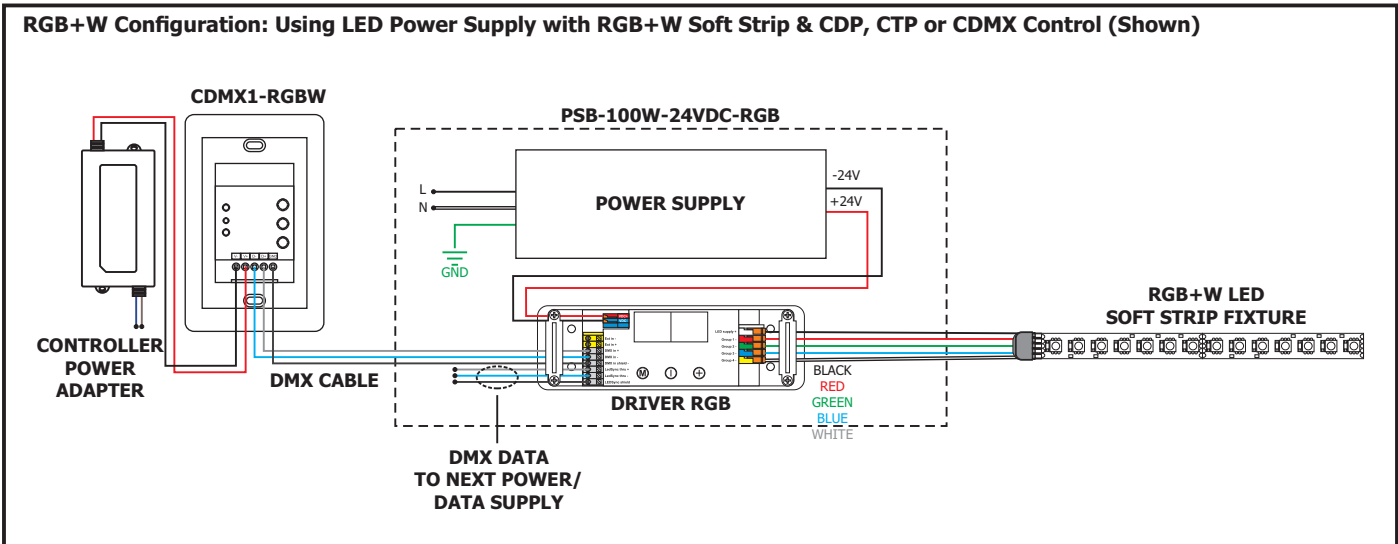
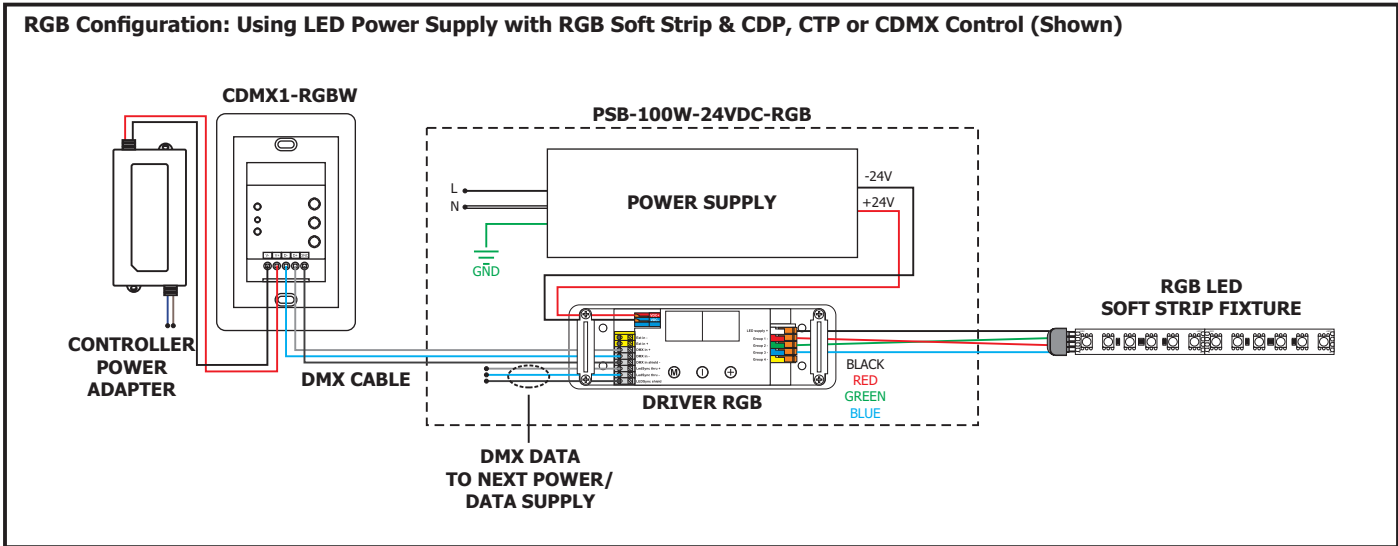
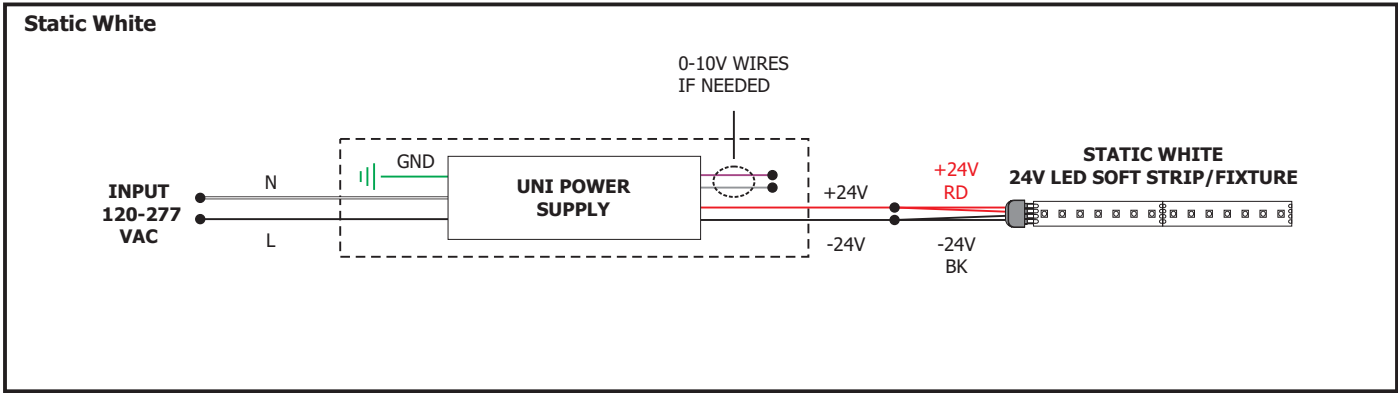

**Tunable White: 2XK Power Supply with DMX Controls**

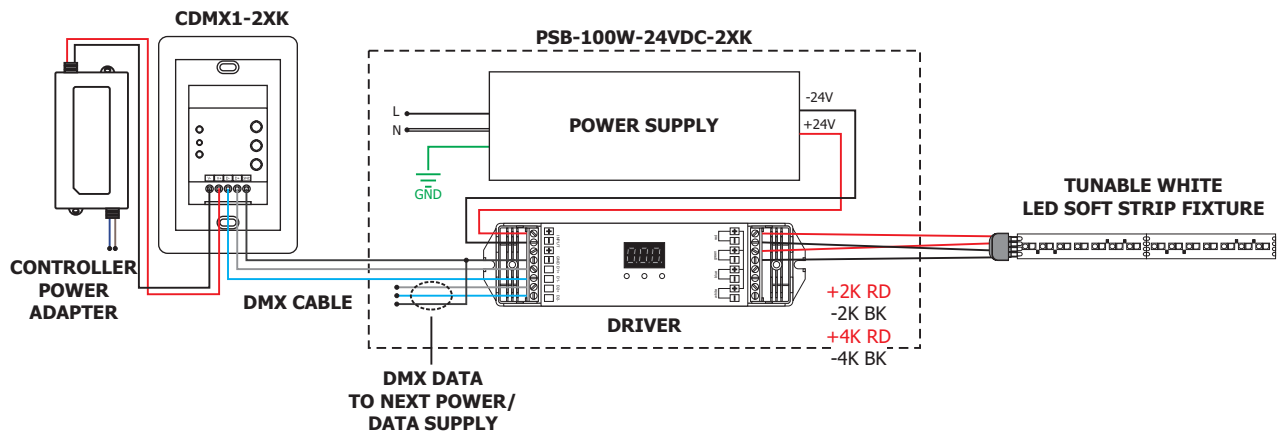

**Tunable White: LED Power Supply with two Channel Controls, for Intensity and Color Temperature**

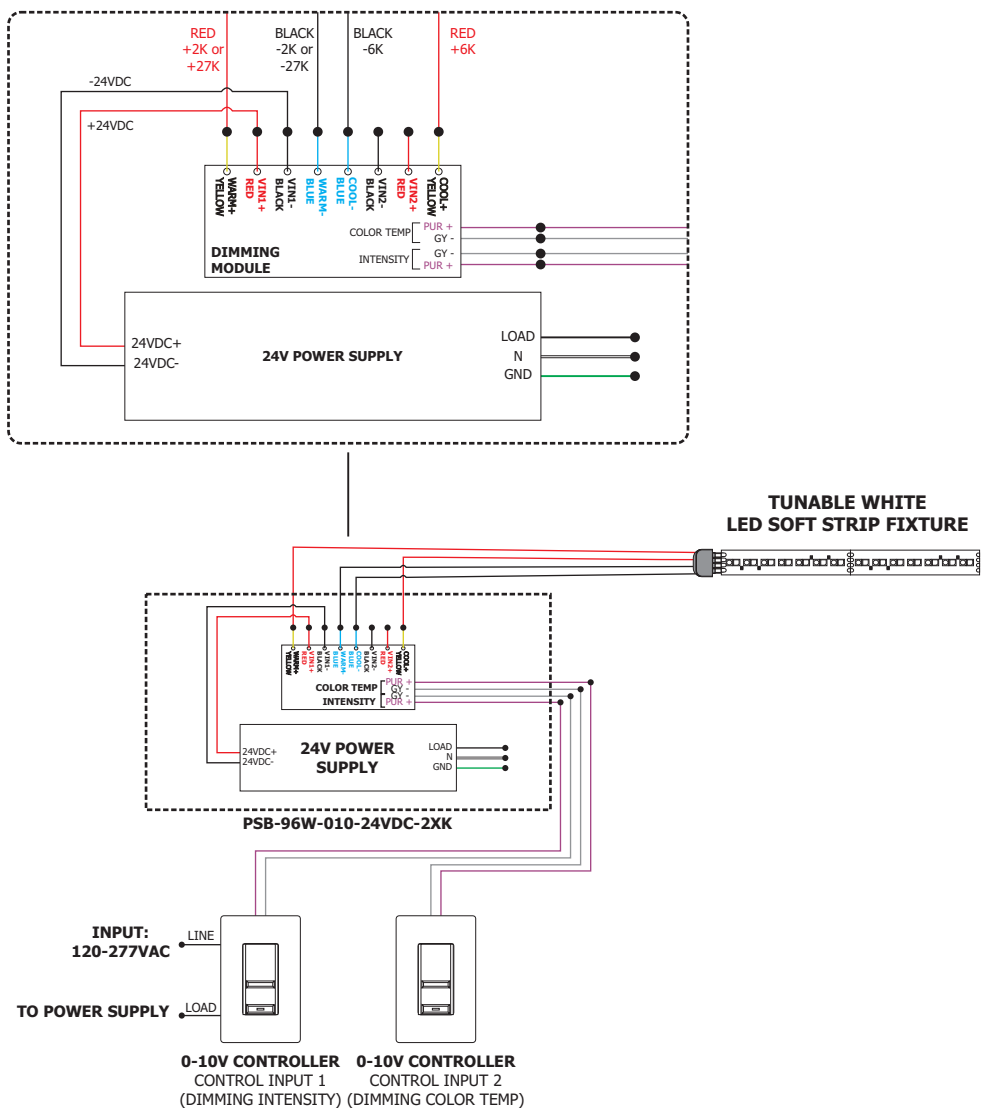



## IMPORTANT INFORMATION REGARDING INSTALLATION AND REWORK OF SOFT STRIP LED

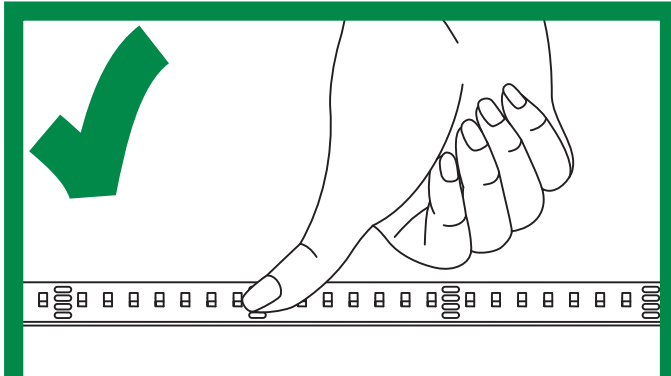
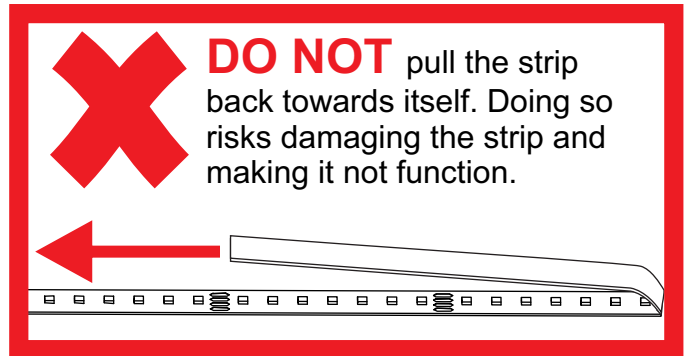
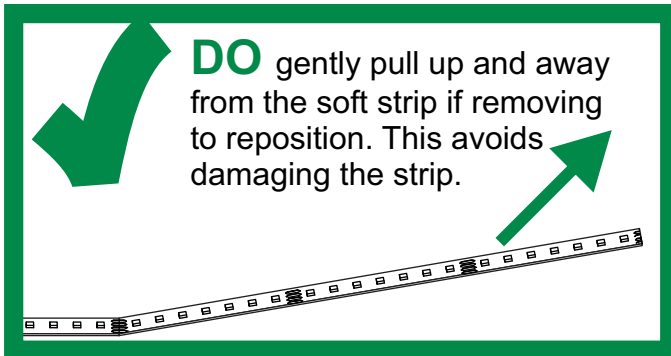

**DO** only ever use fingers to gently install soft strip to a surface **AFTER** cleaning the surface with alcohol.

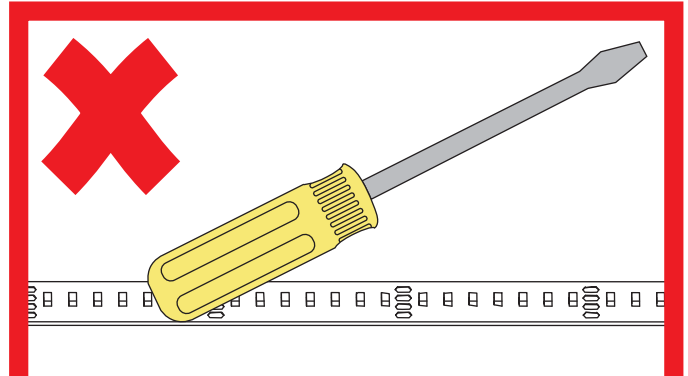

**DO NOT** use any tool to install soft strip to a surface. This will damage the soft strip component.

### Relocating Soft Strip (Optional)

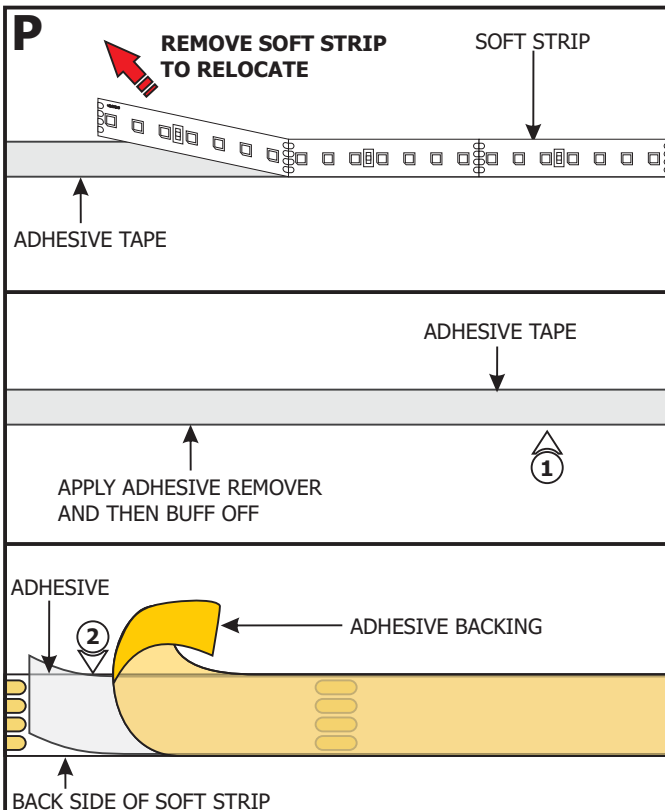

**NOTE:** If relocating the installed soft strip, make sure that the adhesive tape on back of the soft strip covers the entire strip. The adhesive tape isolates the strip from the installation surface. Damaged or inconsistent adhesive tape may cause the contacts on the back of the strip to come in contact with the conductive heat sink which will cause the strip to short and burn. Call Edge Lighting to get replacement adhesive tape and/or optional aluminum heat sink tape (SS-HR-F).

- 1:** To remove tape residue from back of the strip, apply WD-40, Goo Gone, or a mixture of warm water and lemon oil to the corner of a clean, dry towel. Gently buff the area containing the adhesive residue until it is completely removed.
- 2:** Gently remove a few inches from one side of the tape backing. Attach the adhesive tape to the back of the soft strip and apply moderate pressure to affix the tape. Continue this step a few inches at the time until the entire adhesive tape is attached to back of the soft strip.
- 3:** Refer to Section Five to reinstall the soft strip.