



1718 W. Fullerton Chicago, IL 60614
 Ph: 773.770.1195 • Fax: 773.935.5613
 www.PureEdgeLighting.com • info@PureEdgeLighting.com
 © 2016 PureEdge Lighting. All Rights Reserved.

Installation Instructions for Zip Ceiling/Wall Build-It-Yourself

ZC__ _

IMPORTANT INFORMATION

- This instruction shows a typical installation.
- This product is ceiling or wall mount.
- Room Wrapping Design Note: This product installs on a horizontal single surface around the perimeter of a room or on a wall vertical plan across the ceiling.

SAVE THESE INSTRUCTIONS!

Section One: 4" Square Split Canopy

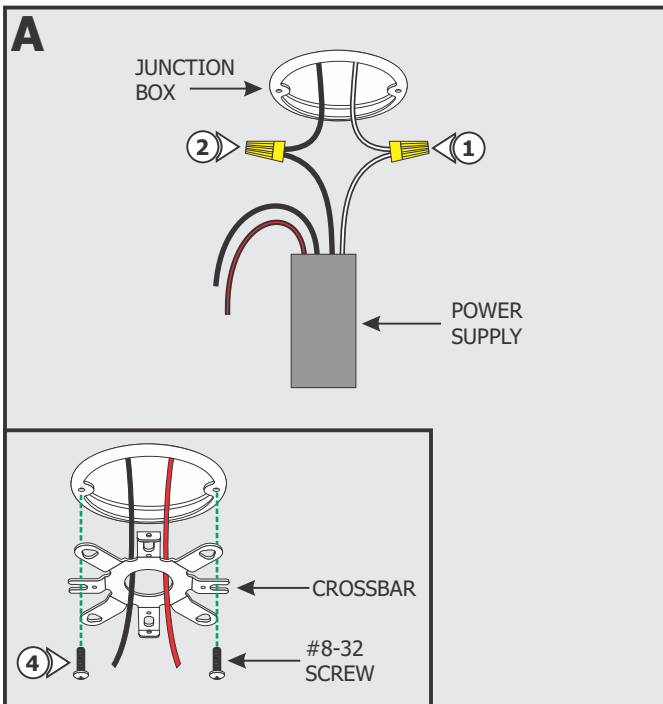

NOTE: Omit this section if using 1" Rectangle Canopy. See Section Two.

NOTE: Omit steps 1 through 3 if using remote power supply.

NOTE: Remote power supply must be installed within 40ft of junction box. Ensure remote power supply wires are present in the junction box. Refer to instructions provided with the power supply.

- 1:** Connect the white wire of the power supply to the 120VAC neutral wire with a wire nut.
- 2:** Connect the black wire of the power supply to the 120VAC line wire with a wire nut.
- 3:** Place the power supply and all wire nut connections inside the junction box.
- 4:** Feed the low voltage wires from the power supply through the crossbar center hole and mount the crossbar to the junction box holes using two #8-32 screws.
- 5:** Complete installation by following steps in Section Three.

Section Two: 1" Rectangle Canopy

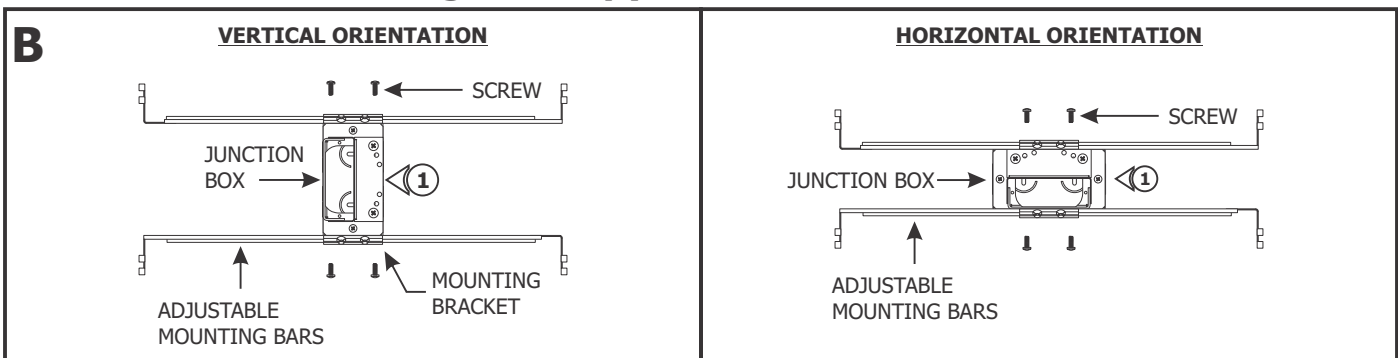

NOTE: Omit this section if using 4" Square Split Canopy.

- 1:** Mount each adjustable mounting bar to one side of the junction box (mounts to any side of the housing depending on the orientation of the channel) and secure them with the mounting brackets and Phillips screws provided.

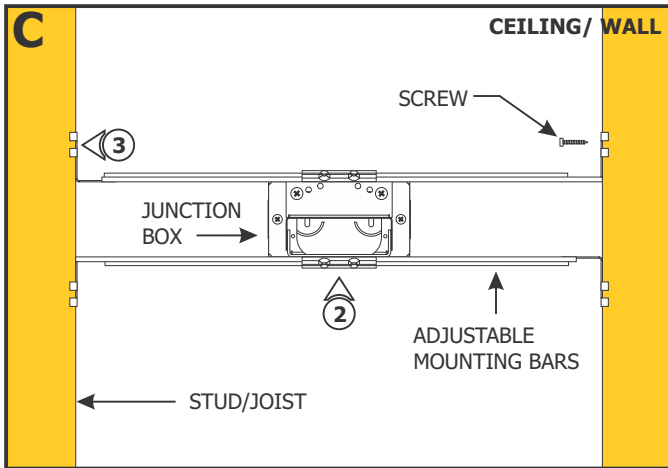

NOTE: The adjustable mounting bars mount to studs/joists that are spaced 15"-24" apart. If the span needs to be shorter than 15", then break the arms at dedicated lines.

NOTE: Ensure the opening of the junction box is aligned with the center of the desired fixture location. If necessary, adjust the junction box location by loosening the screws and sliding the junction box to the proper location. Tighten the Phillips screws after adjusting.

- 2:** Select the location between two studs/joists to mount the junction box.
- 3:** Place the lips of the adjustable mounting bars against the studs/joists. Secure the adjustable bars to the studs/joists with the #8 screws.

4: Remove a knockout to install a conduit into the junction box.

5: Install conduit(s) (if required by local electrical code) and run 120V power wires to the junction box.

NOTE: If using remote power supply, then run the low voltage wires coming from the power supply into the junction box.

NOTE: Remote power supply must be installed within 40ft of junction box. Ensure remote power supply wires are present in the junction box. Refer to instructions provided with the power supply.

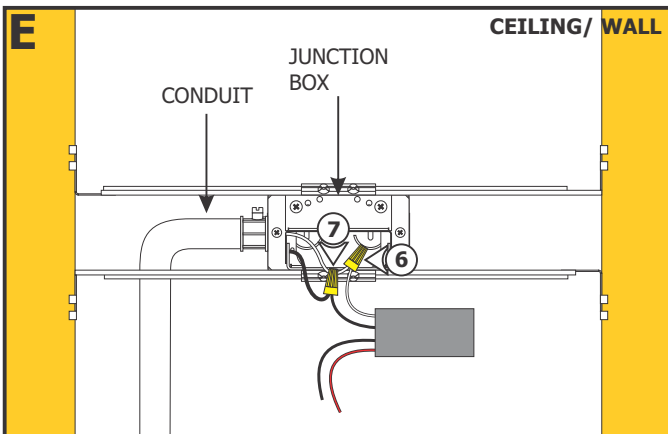
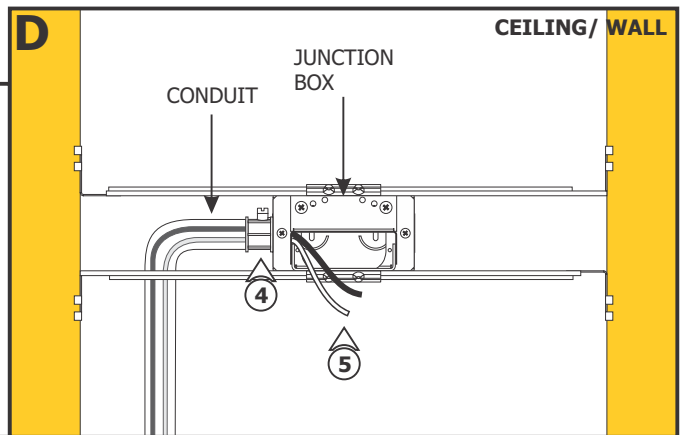

NOTE: Omit steps 6 through 8 if using a remote power supply.

- 6:** Connect the white wire of the power supply to the 120VAC neutral wire with a wire nut.
- 7:** Connect the black wire of the power supply to the 120VAC line wire with a wire nut.
- 8:** Place the power supply and all wire nut connections inside the junction box.

9: Mark a rectangle shape on the drywall where the junction box opening will be located depending on the selected position.

10: Cut out the marked rectangle opening, using a "Dremel Multi-Max" with the "wood & drywall" cutting bit.

11: Install & finish drywall.

12: Complete installation by following steps in Section Three.

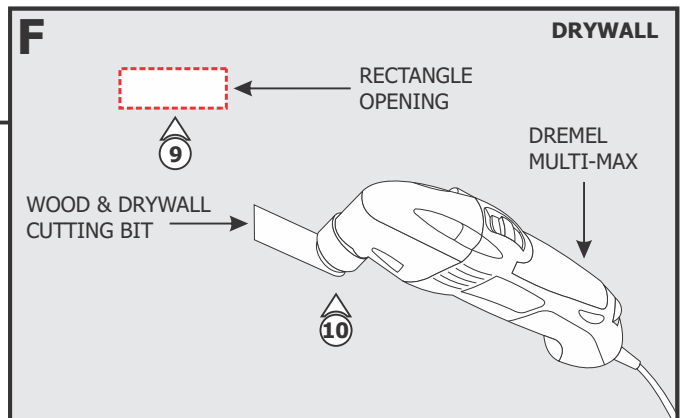

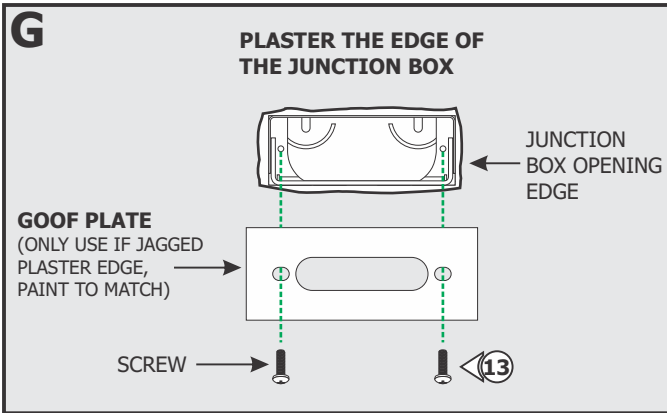

13: Optional: Use the Goof Plate if the junction box opening has imperfection/ jagged edges. Install the provided goof plate (paint to match prior) with the two screws.

Section Three: Assemble the Fixture

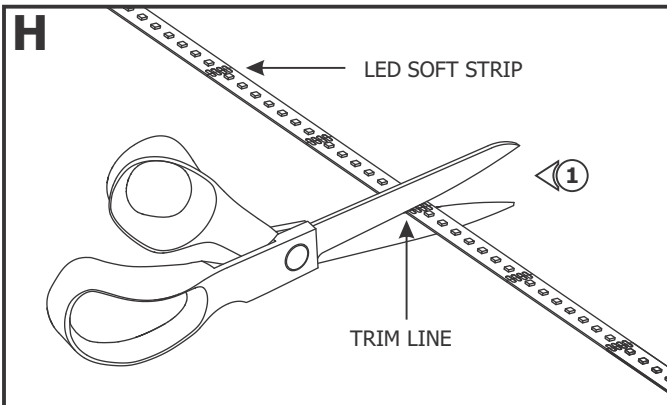

NOTE: Do not trim the strip at unmarked sections which may cause that section of the strip to not light up.

1: Determine the amount of LED Soft Strip needed. Trim the LED Soft Strip at the marked line above the contacts with a sharp scissor.

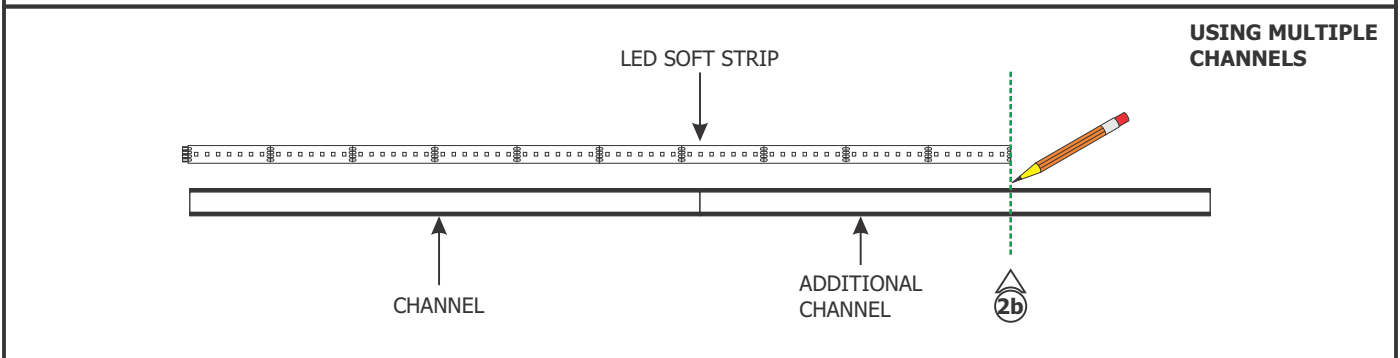
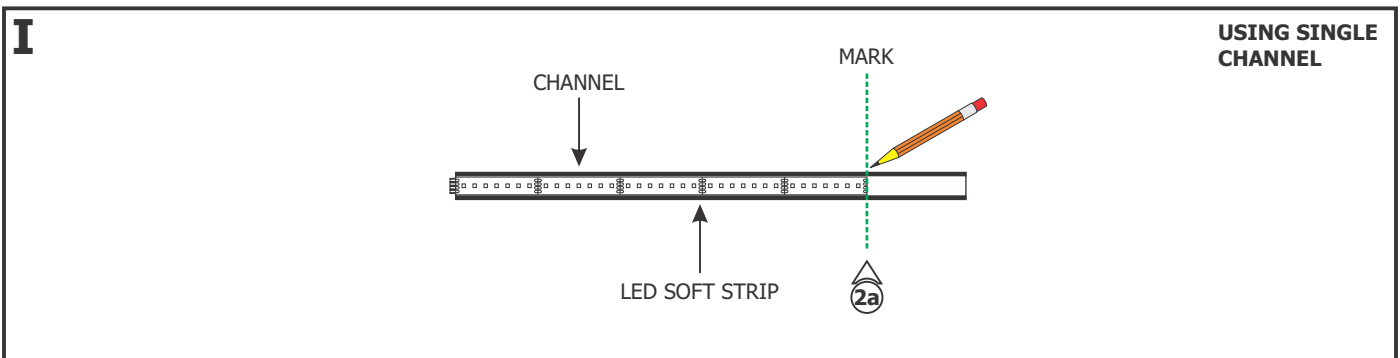

2a: Lay the LED Soft Strip inside the channel flush to one end and mark the length of the LED Soft Strip on the channel.

2b: For multiple channels, put the channels next to each other from one end to another. Lay the LED Soft Strip inside both channels flush to one end and mark the length of the LED Soft Strip on the channel.

3: Remove the LED Soft Strip.

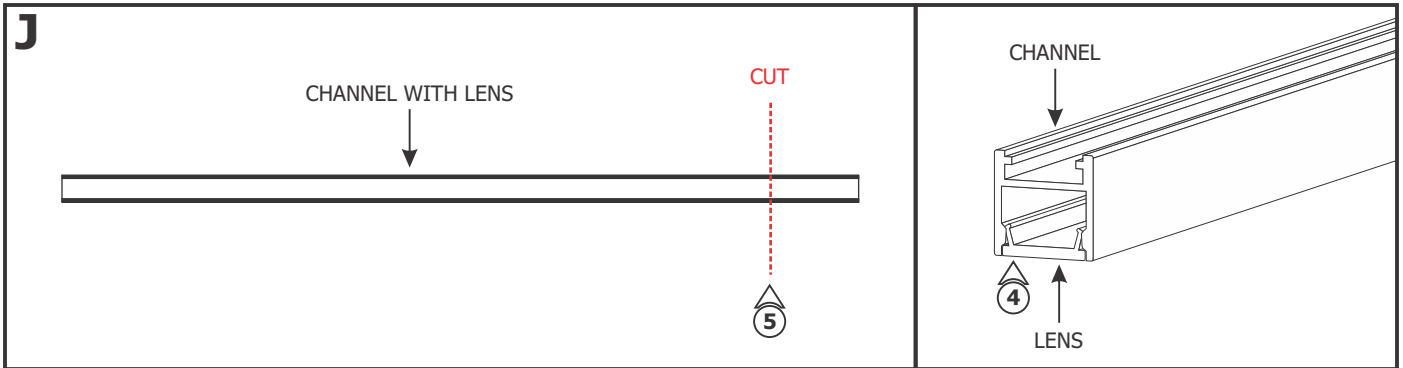

4: Snap the lens on the channel **BEFORE** cutting to length. This ensure a proper fit after installation.

5: Cut the channel and lens to match the LED Soft Strip length.

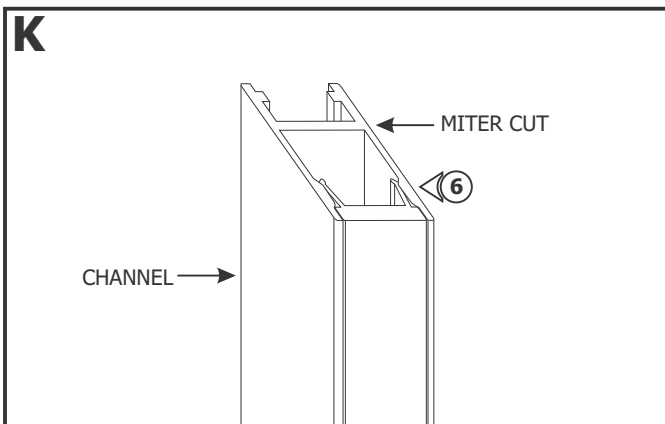

6: For Room Wrapping Installations, miter cut the channel and lens to match the angle of the corner. In a 90° inside or outside installation, each channel section is cut at a 45° angle to form a complete corner.

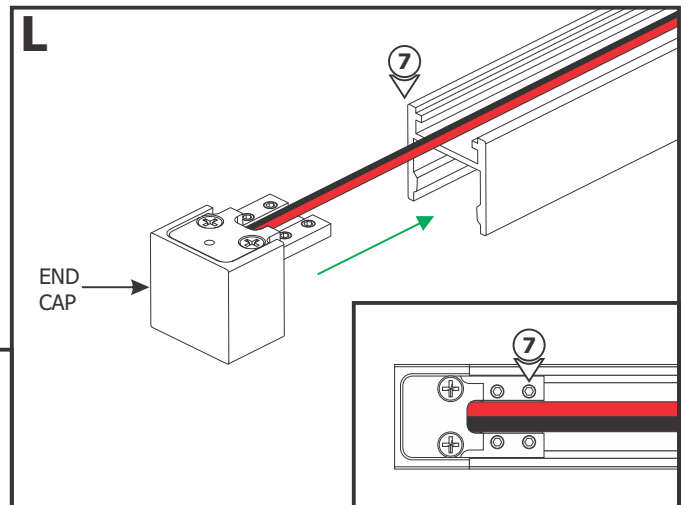

7: Slide the power end cap (CAP) into the end of the channel. Secure by tightening the four #4-40 set screws using a 0.05" Allen wrench.

8: Repeat step 7 to install the Dead End Cap (DCA).

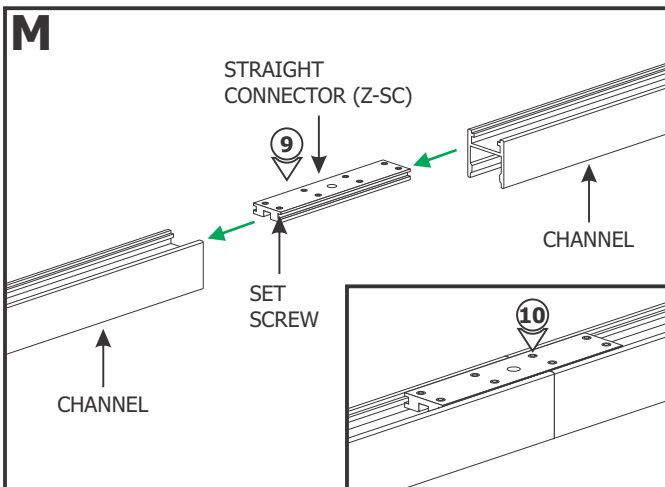

9: To join two channels in a straight run, insert the Straight Connector (Z-SC) halfway into one channel. Tighten the four 4-40 set screws with a 0.05" Allen wrench.

10: Slide the other channel onto the Straight Connector and tighten the remaining set screws.

Section Four: Install the Mounting Clips for Drywall Ceiling/Wall

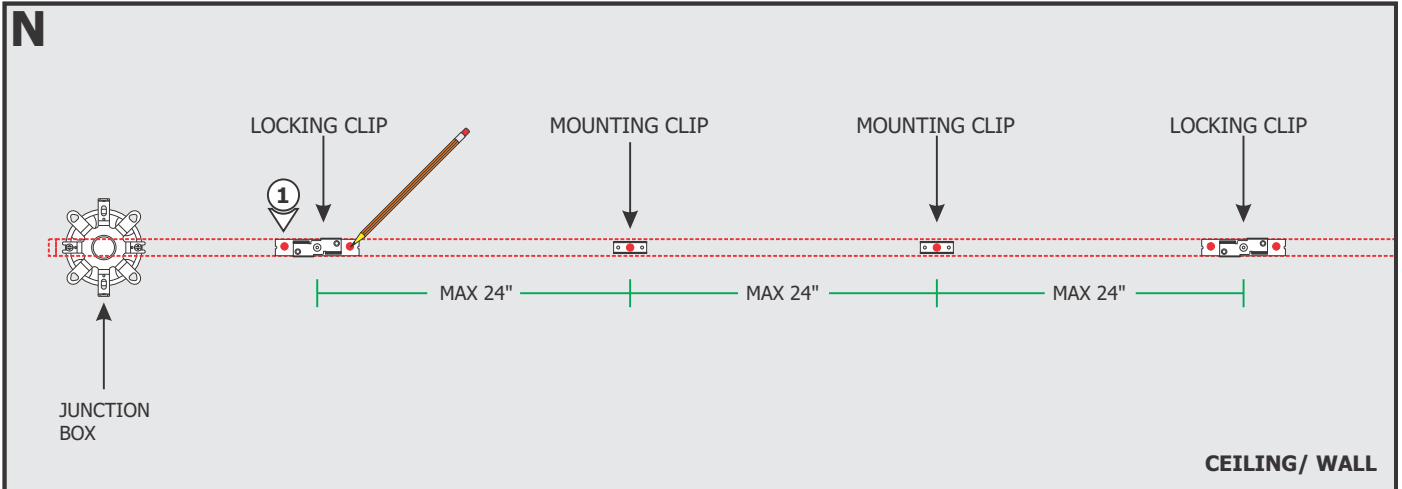

NOTE: Omit this section if mounting onto T-Bar Ceilings. Refer to Section Six and Seven to install onto T-Bar Ceilings.

NOTE: 4" Square Split Canopy shown for demonstration purposes.

NOTE: The channel must pass through the center of the junction box.

1: Begin installation using side of the channel with power wires. Lay the channel to the desired location & make all necessary markings on the ceiling or wall which will consist of the channel ends, mounting clips, or locking clips. Clips must be installed maximum 24" from each other.

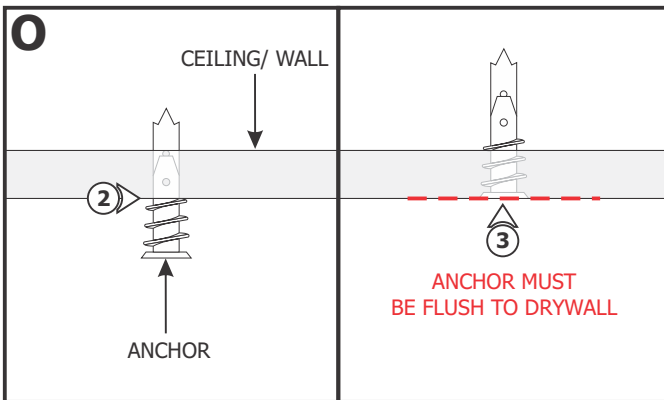

NOTE: Steps 2 and 3 are for drywall mounting. Omit these steps if mounting the clips to a wood surface directly.

Install Anchor(s):

- 2:** Tap the anchor onto the marked point up to the threaded portion with a hammer.
- 3:** Screw in the threaded portion of the anchor with a Phillips screwdriver.

Ceiling Mounting Clips (recommended):

- 4:** Line up the mounting clip to the anchor and secure by tightening the screw through the center clip hole into the anchor.

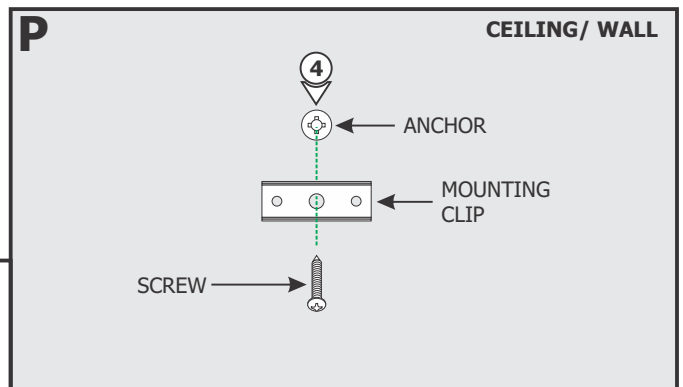

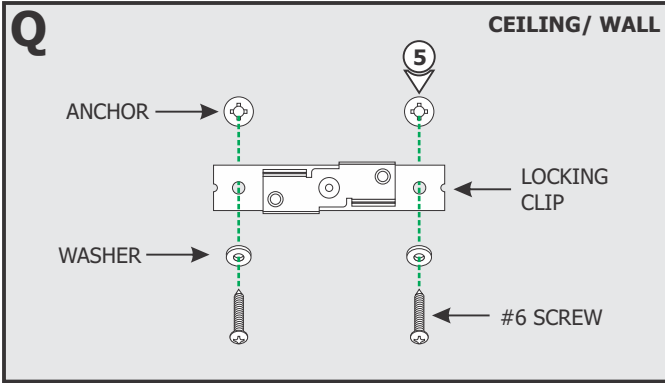

Ceiling Mounting Locking Clip (recommended):

5: Line up the locking clip to the anchors and secure them by tightening the two #6 screws through the washers and clip holes into the anchors.

Section Five: Power the Fixture for Drywall Ceiling/Wall

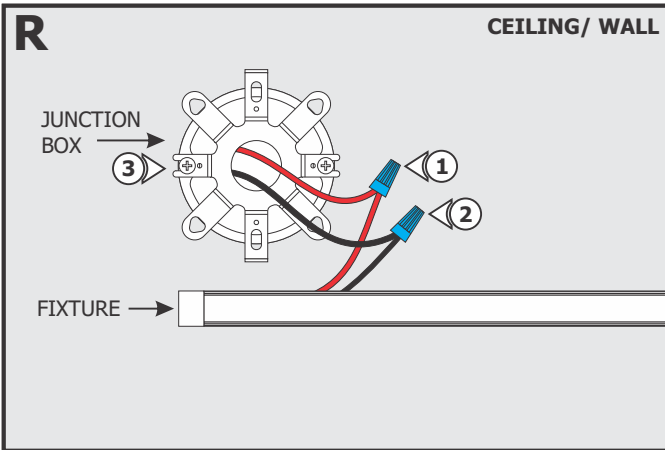

1: Connect the low voltage +24VDC power supply wire to the red wire of the fixture using a wire nut.

2: Connect the low voltage -24VDC power supply wire to the black wire of the fixture using a wire nut.

3: Place all wire nut connections inside the junction box.

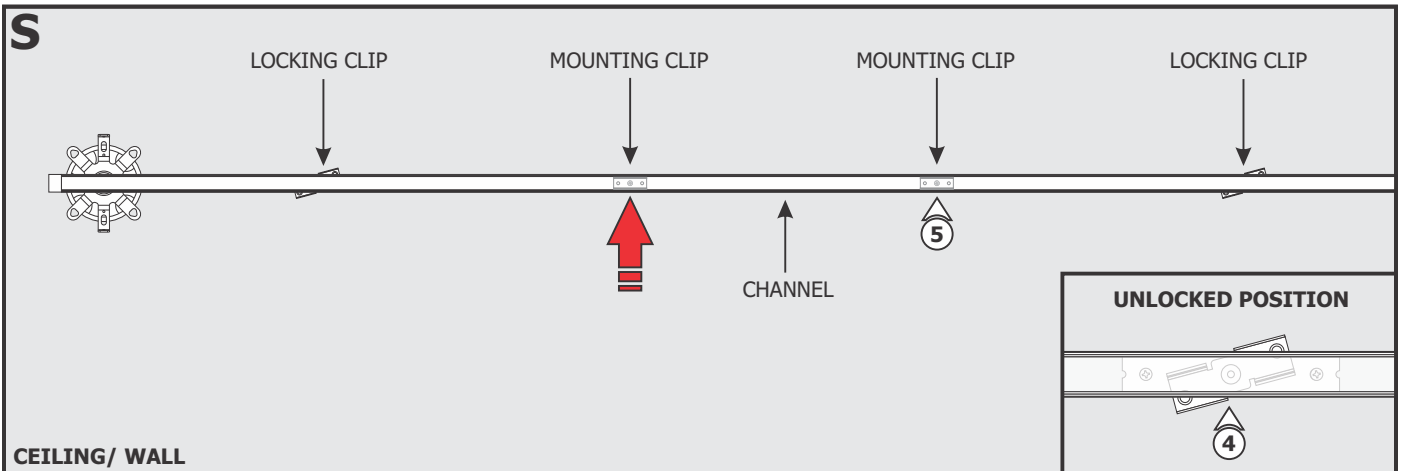

4: Make sure the locking clips are in the unlocked position before installing the fixture to the mounting clips.

5: Carefully SNAP the channel onto the mounting clips. Make sure not to nick the wires.

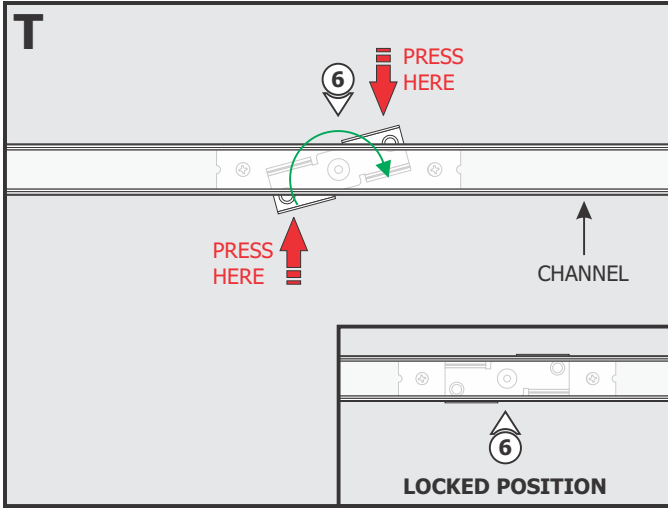

6: Twist each locking clip to lock the channel in place.

7: Align additional channels with corners. Repeat steps 4 through 6 to lock the channels in place.

8: Continue installation by following steps in Section Eight.

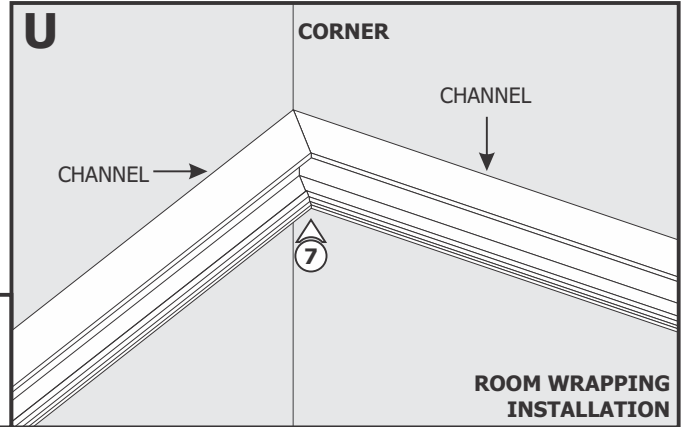

Section Six: Install the Mounting Clips for T-Bar Ceilings

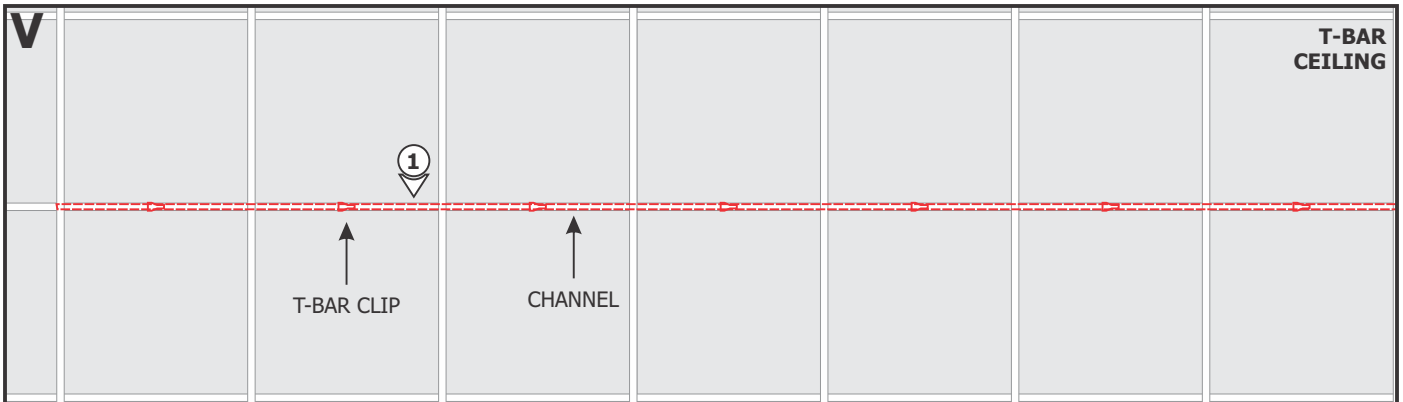

NOTE: Omit this section if mounting onto drywall ceilings/walls.

1: Determine the location of the channel on the T-Bar ceiling.

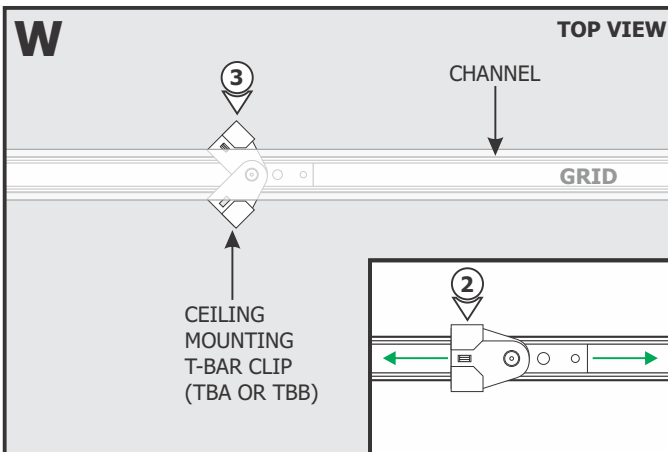

Ceiling Mounting T-Bar Clips for Flush Ceiling Panels TBA and Ceiling Panels 3/8" below grid TBB:

2: Adjust the position of the Ceiling Mounting T-Bar Clip on the channel and align channel with the ceiling grid.

3: Open the T-Bar clip arms to fit over the grid.

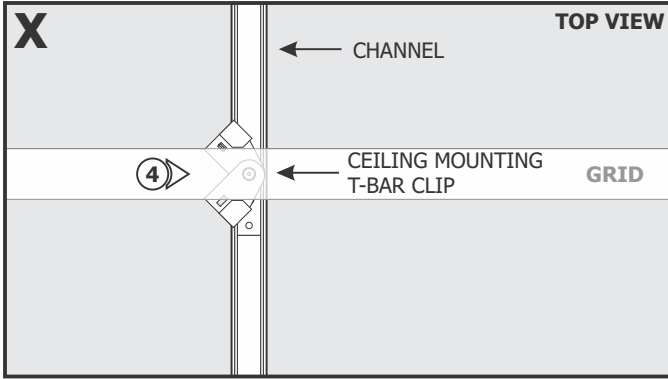

4: If aligning the channel perpendicular to the grid, rotate the arms into position.

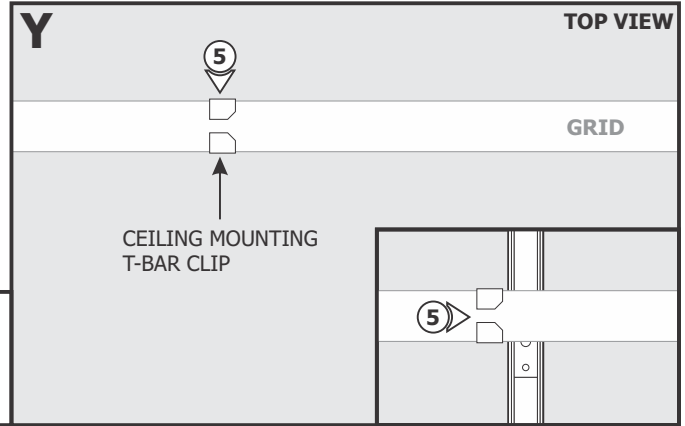

5: Place the T-Bar clip onto the grid and squeeze the arms together to secure in place.

6: Repeat for the other Ceiling Mounting T-Bar clips.

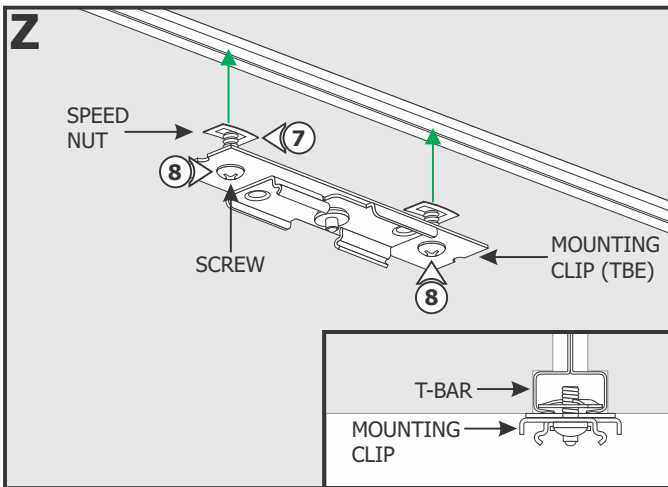

T-Bar End Mounting Clip TBE (For T-Bar 9/16" Grid)

7: Ensure the speed nuts on the T-Bar End Mounting Clip are parallel with the T-Bar. Insert the T-Bar End Mounting Clip into the T-Bar and adjust the position.

8: Tighten the two Phillips screws to secure in place.

9: Repeat for the other T-Bar End Mounting Clips.

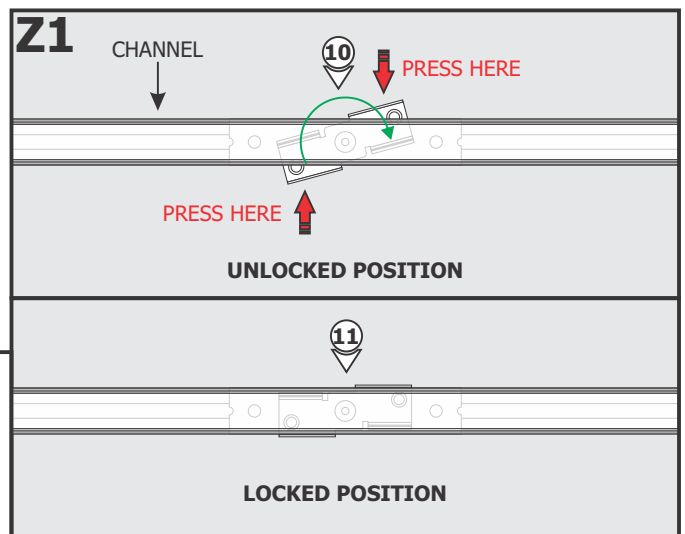

10: Make sure the T-Bar End Mounting Clips are in the unlocked position before placing the channel over the T-Bar End Mounting Clips.

11: Twist each T-Bar End Mounting Clip to lock the channel in place.

Section Seven: Power the Fixture for T-Bar Ceilings

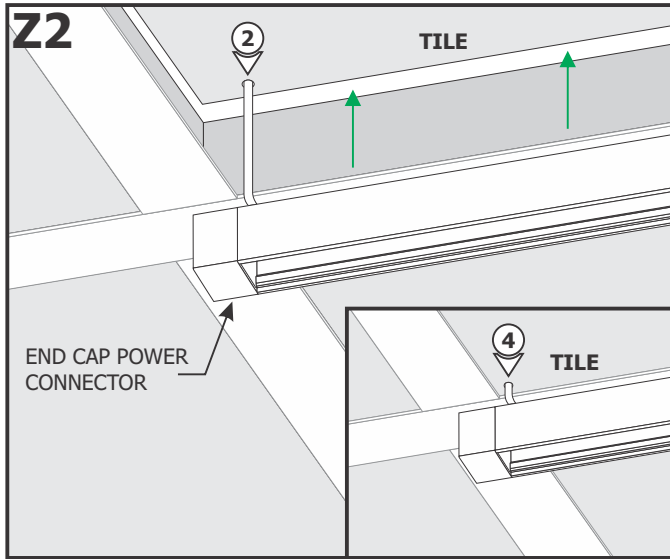

- 1:** Mark the location of the power cord on the ceiling tile. Remove the ceiling tile.
- 2:** Drill a hole through the ceiling tile and feed the power cord through the hole.
- 3:** Route the power cord to the remote power supply. Refer to the instructions provided with the power supply.
- 4:** Replace the ceiling tile.

- 5:** Strip 3/8" off of the fixture power wires and the 24VDC power supply wires.
- 6:** Pull up the levers of one lever nut and insert the +24VDC power supply wire and the red fixture wire. Push the levers down to connect and lock in place.
- 7:** Pull up the levers of the second lever nut and insert the -24VDC power supply wire and the black fixture wire. Push the levers down to connect and lock in place.
- 8:** Lightly tug on the wires to ensure they are secured in place.

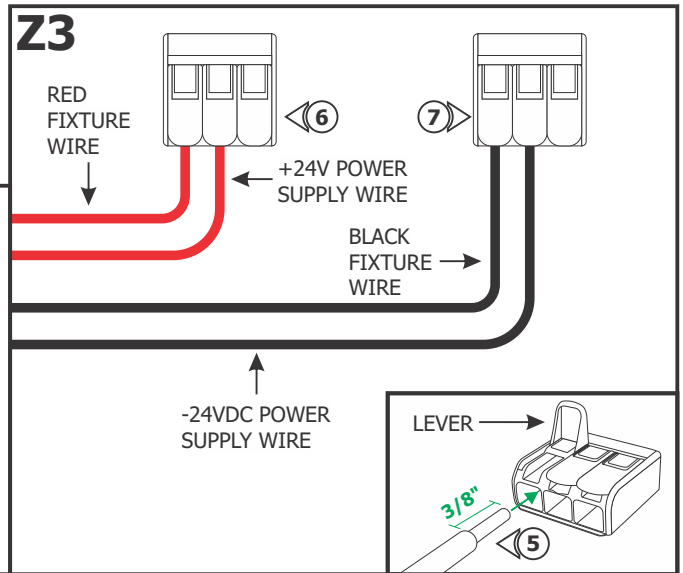

Section Eight: Install the LED Soft Strip, Lens and Canopy

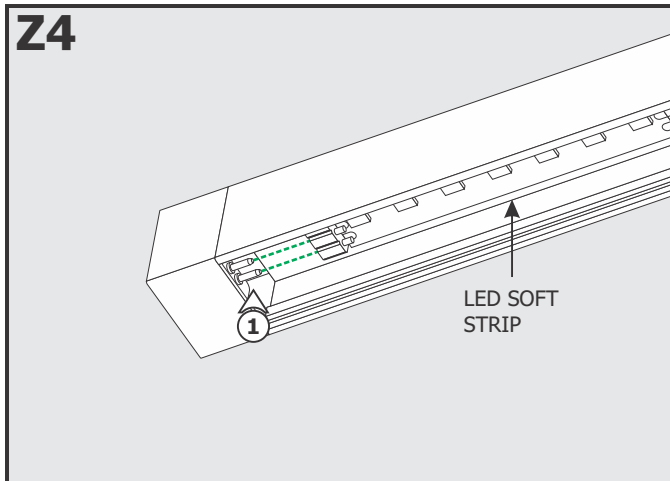

- 1:** Carefully remove the backing from the LED Soft Strip, making sure not to remove the tape from the LED Soft Strip. Push the LED Soft Strip onto the pins of the powered end cap until they are properly mated.
- 2:** Firmly press down the adhesive portion of the LED Soft Strip onto the surface of the channel while removing the rest of the backing, making sure there are not air bubbles that can cause surface irregularities.

NOTE: Refer to page 12 for more important information regarding installation and rework of the LED strip.

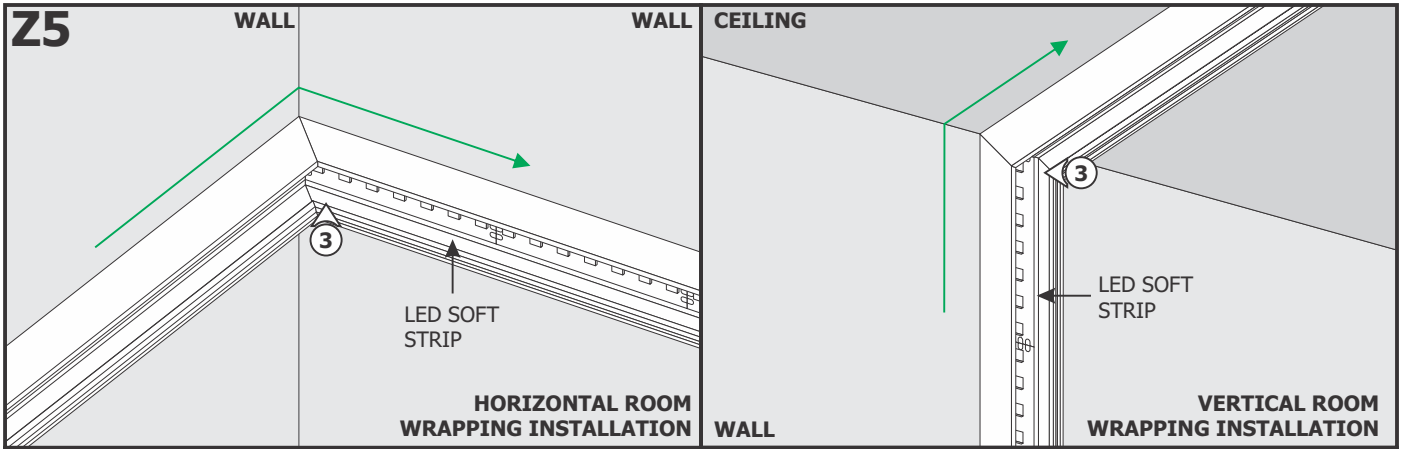

3: For Room Wrapping configurations, bend the LED Soft Strip 90° flat on the channel to match the channel corners. Ensure the entire length of the channel is covered with LED strip to avoid unlit areas.

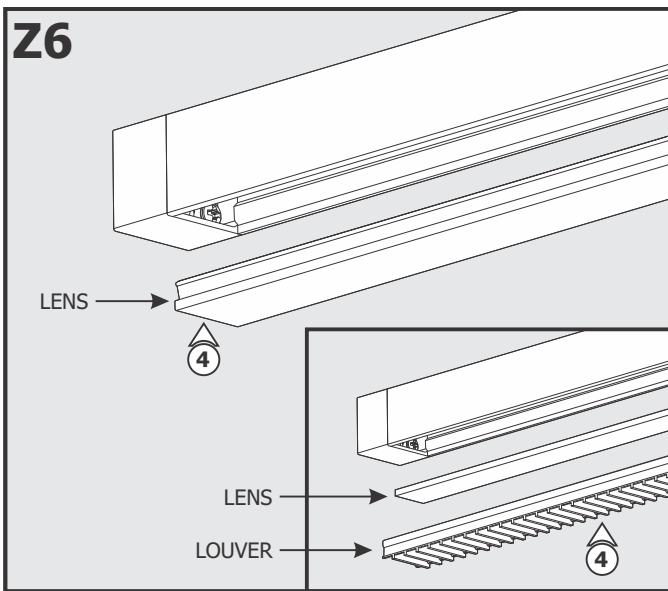

4: Snap the lenses and optional louvers to the assembled channels.

5: For 4" Square Split Canopy installations, place each canopy piece against the fixture and align the canopy holes with the crossbar holes. Secure the canopy pieces in place with the two #4-40 screws and 1/16" Allen wrench provided.

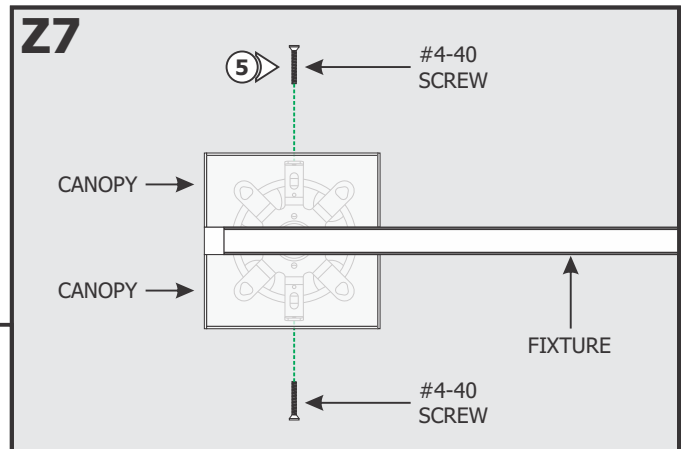

96W, 24VDC LOW VOLTAGE WIRE SIZE CHART

3% VOLTAGE DROP	WIRE LENGTH IN FT	UP TO 33FT	35FT-52FT	53FT-86FT	87FT-130FT
	WIRE SIZE	14 AWG	12 AWG	10 AWG	8 AWG
	VOLTAGE AT END OF THE WIRE	23.28VDC	23.29VDC	23.28VDC	23.28VDC

General Wiring Diagrams

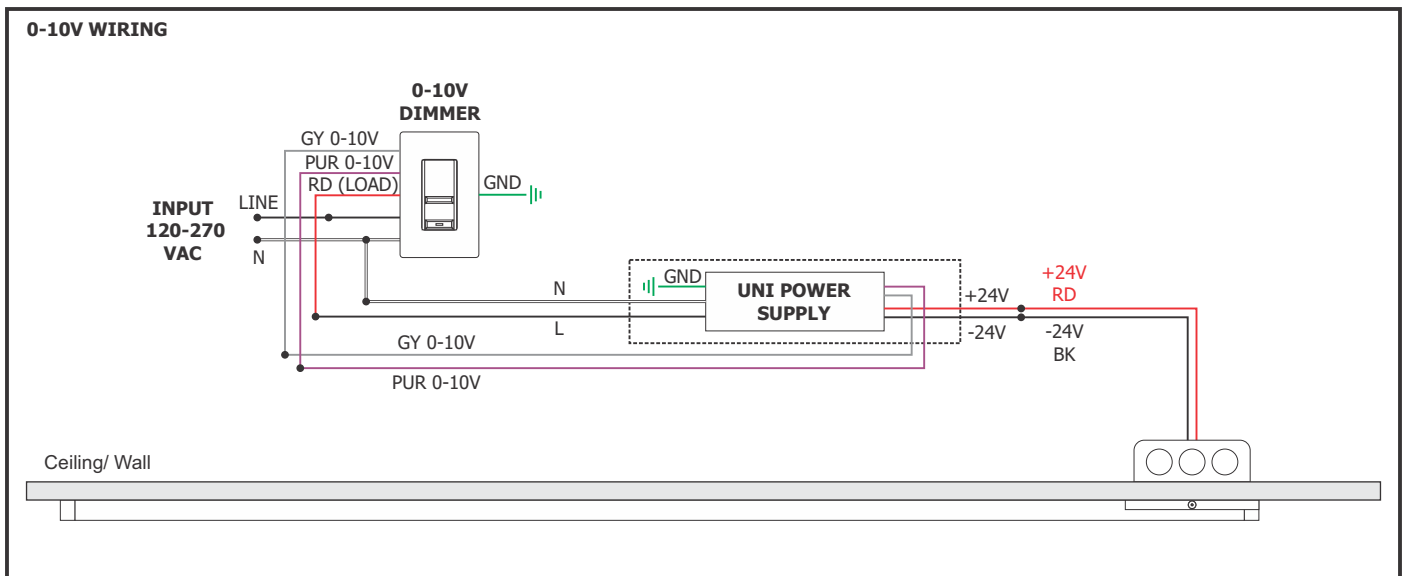
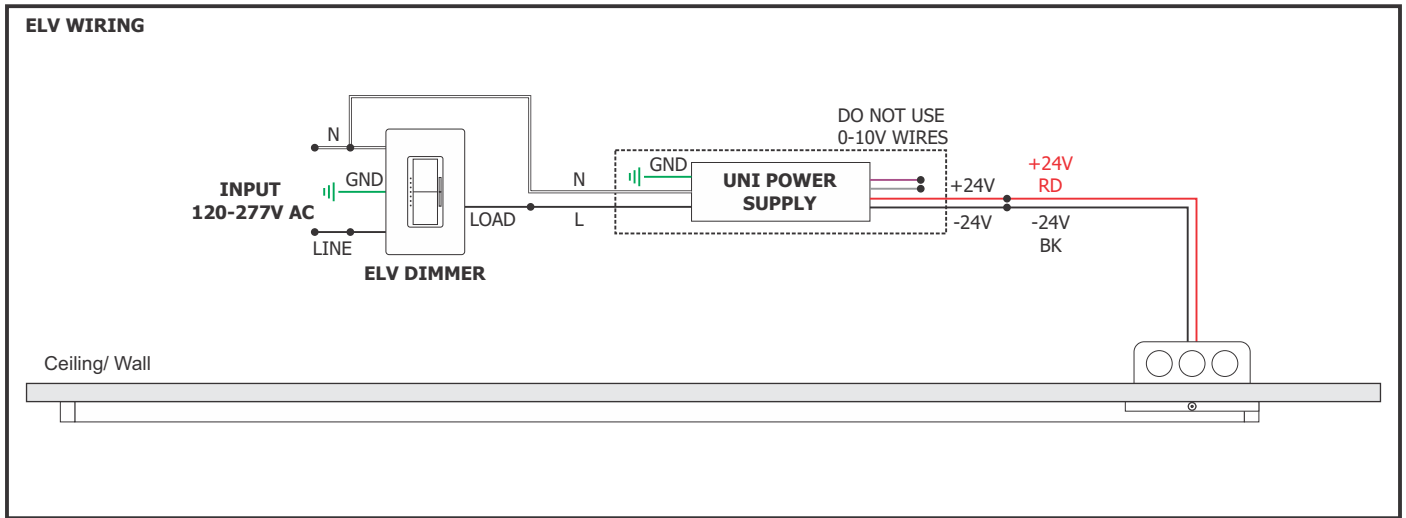

IMPORTANT INFORMATION REGARDING INSTALLATION AND REWORK OF SOFT STRIP LED

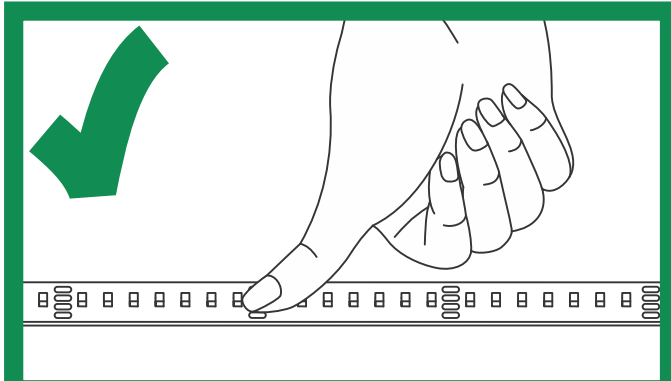
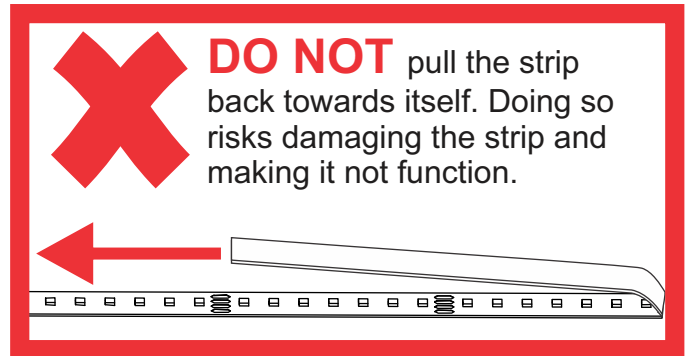
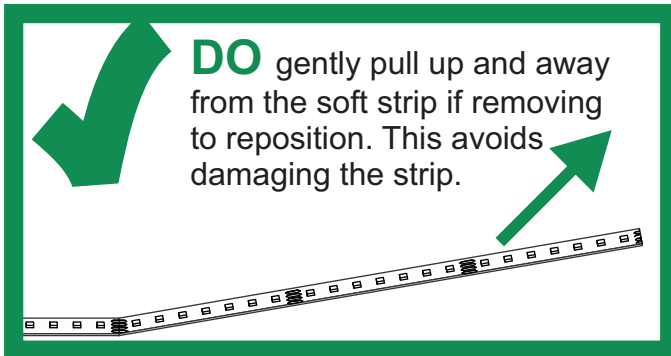

DO only ever use fingers to gently install soft strip to a surface **AFTER** cleaning the surface with alcohol.

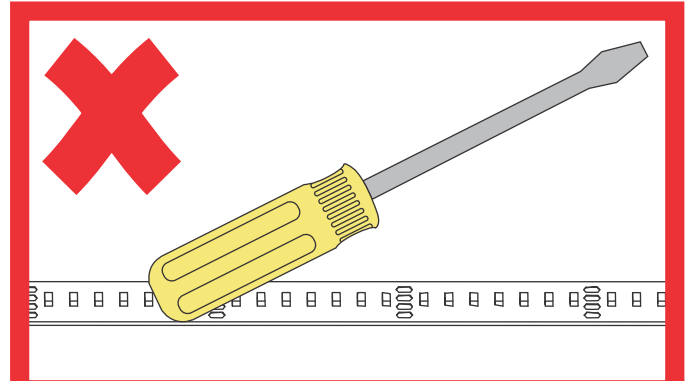

DO NOT use any tool to install soft strip to a surface. This will damage the soft strip component.

Relocating Soft Strip (Optional)

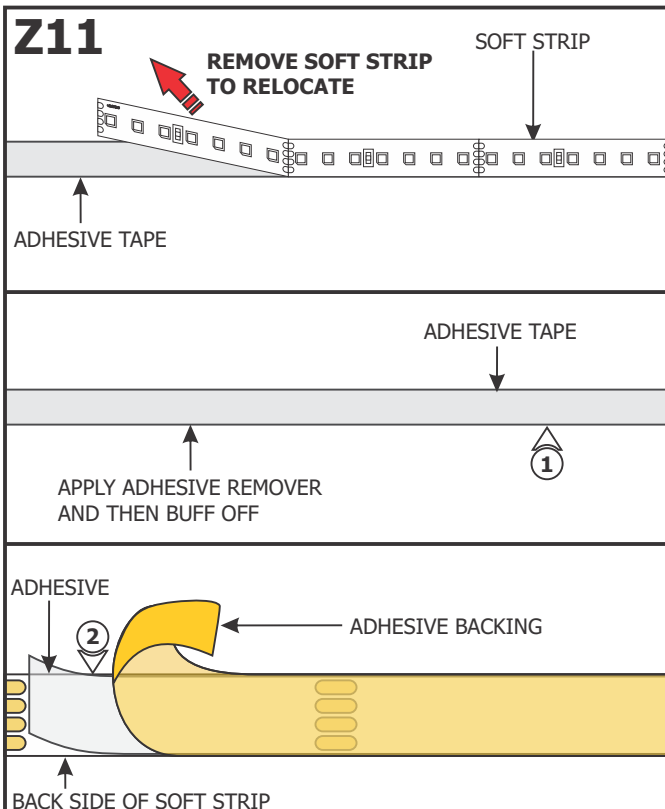

NOTE: If relocating the installed soft strip, make sure that the adhesive tape on back of the soft strip covers the entire strip. The adhesive tape isolates the strip from the installation surface. Damaged or inconsistent adhesive tape may cause the contacts on the back of the strip to come in contact with the conductive heat sink which will cause the strip to short and burn. Call Edge Lighting to get replacement adhesive tape and/or optional aluminum heat sink tape (SS-HR-F).

- 1:** To remove tape residue from back of the strip, apply WD-40, Goo Gone, or a mixture of warm water and lemon oil to the corner of a clean, dry towel. Gently buff the area containing the adhesive residue until it is completely removed.
- 2:** Gently remove a few inches from one side of the tape backing. Attach the adhesive tape to the back of the soft strip and apply moderate pressure to affix the tape. Continue this step a few inches at the time until the entire adhesive tape is attached to back of the soft strip.
- 3:** Refer to Section Eight to reinstall the soft strip.