



1718 W. Fullerton Chicago, IL 60614  
 Ph: 773.770.1195 • Fax: 773.935.5613  
 www.PureEdgeLighting.com • info@PureEdgeLighting.com  
 © 2016 PureEdge Lighting. All Rights Reserved.

## Installation Instructions for **Twist Strip LED 3.3W/ft 24 Volt High Output Commercial**

**TS3C-24V\_**

### IMPORTANT INFORMATION

ETL LISTED

 Intertek  
 3028534

- Conforms to UL STD 1598 & UL STD 2108 Certified to CAN/CSA STD C22.2 NO 250.0
- Suitable for Under-Cabinet Mount
- Dry Location Only
- Use Only With Class 2 Power Unit
- Peut être fixé Sous Une Armoire
- Pour Emplacements Secs Seulement
- Utiliser Seulement Avec Classe 2 Unité d'alimentation électrique

**SAVE THESE INSTRUCTIONS!**

## Section One: Prepare the Twist Strip

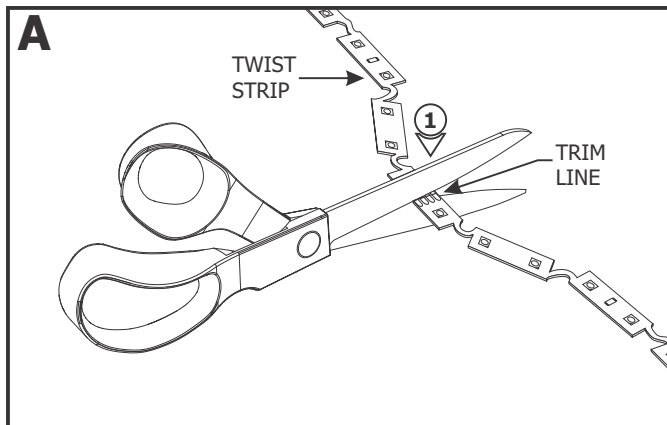

**1:** If necessary trim the LED strip at the marked line above the contact (every 4" apart) with a sharp scissor to fit the design.

**NOTE:** Do not trim the strip over the sections that are joined together by soldering. The soldered contact will not connect to the Snap & Light connector easily.

**NOTE:** Do not trim the strip at unmarked sections which may cause that section of the strip not to light up.

**2:** Place the LED Soft Strip on a flat, stable surface. Using a utility knife, carefully scrape the protective coating from the contacts.

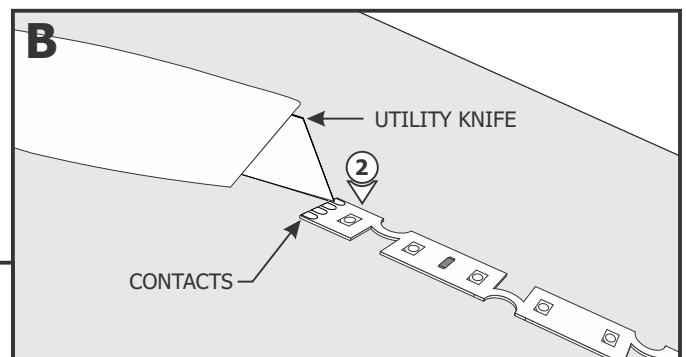

## Section Two: Install the Soft Strip

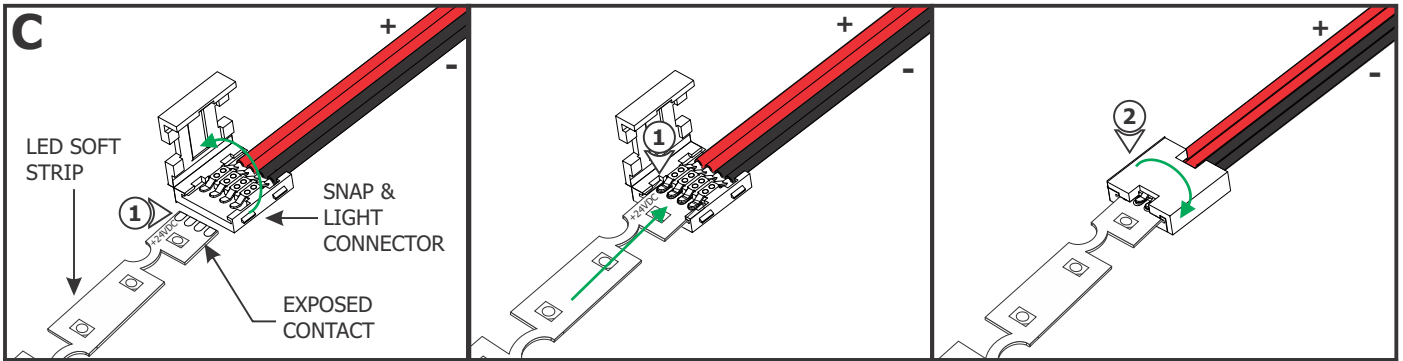

**NOTE:** Aluminum heat sink tape (SS-HR-F) is sold separately to help dissipate heat generated by LEDs.

**1:** Align the +24VDC marking on the soft strip with the red wires of the Snap & Light connector. Insert the exposed contact at the end of the LED strip under the Snap & Light contacts ensuring that the strip contacts are aligned and covered under the connector contacts.

**2:** Close the Snap & Light cover and ensure it snaps securely into place.

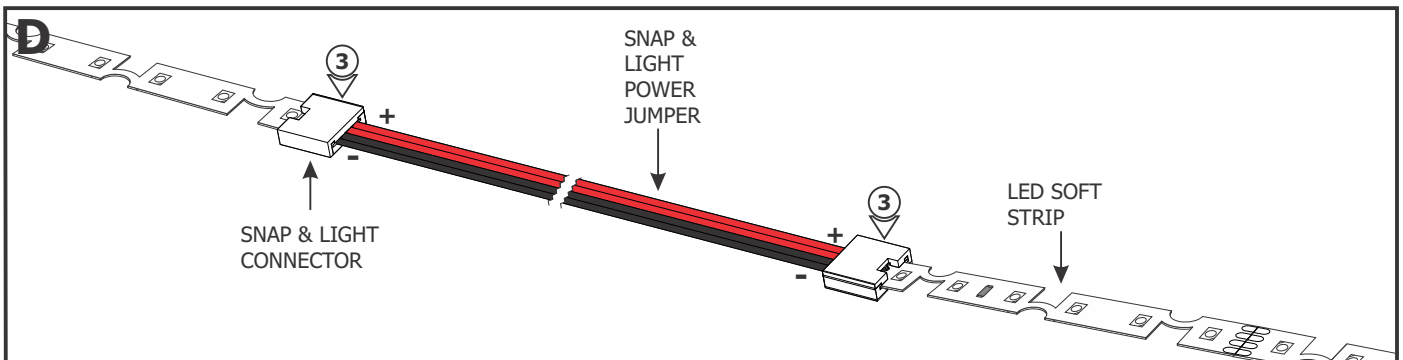

**3:** When using the Snap & Light power jumper with another soft strip, then follow the steps on Section One; steps 1 and 2 on Section Two.

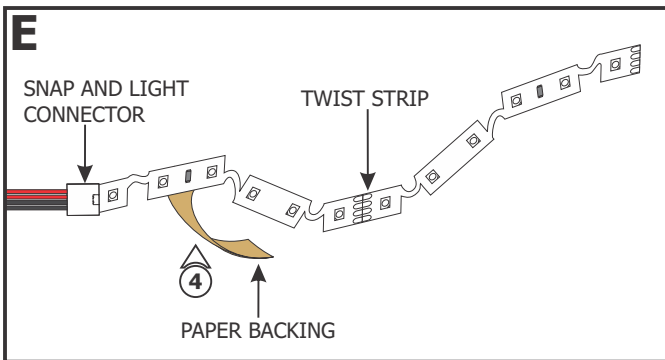

**4:** Carefully remove the backing from the LED twist strip, make sure not to remove the tape from the twist strip. Firmly press down the adhesive portion of the soft strip onto the mounting surface while removing the rest of the backing, making sure there are no air bubbles that can cause surface irregularities.

**5:** Trim the other end of the Snap & Light connector when it is used as the power cord. Refer to the wiring diagram on page 4 and the instructions provided with the power supply to complete the installation.

**NOTE:** TS3C Twist Strip consumes on average 3.3 Watt per foot.

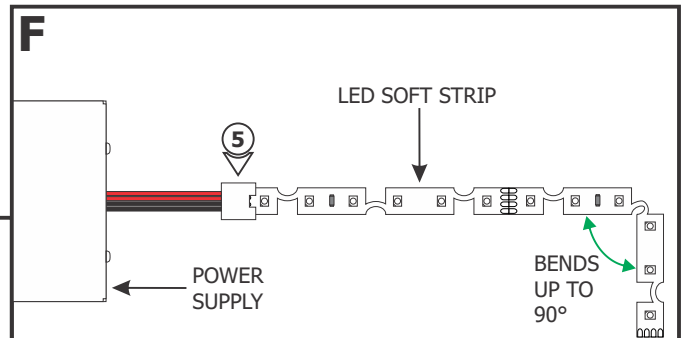

## IMPORTANT INFORMATION REGARDING INSTALLATION AND REWORK OF SOFT STRIP LED

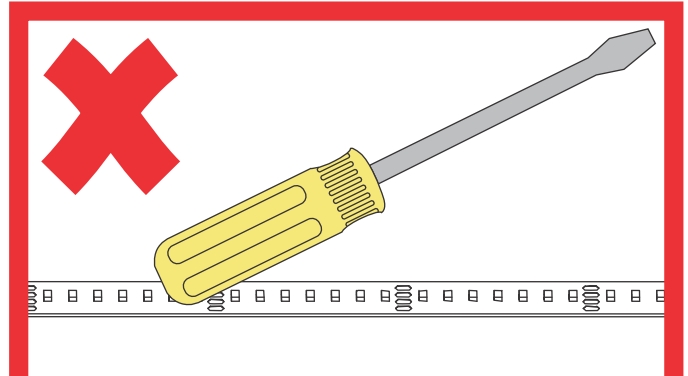
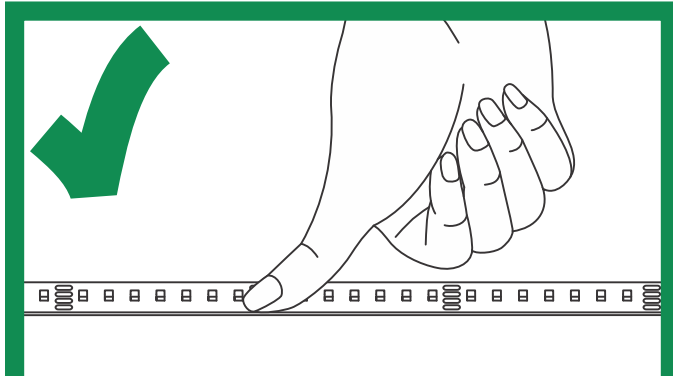
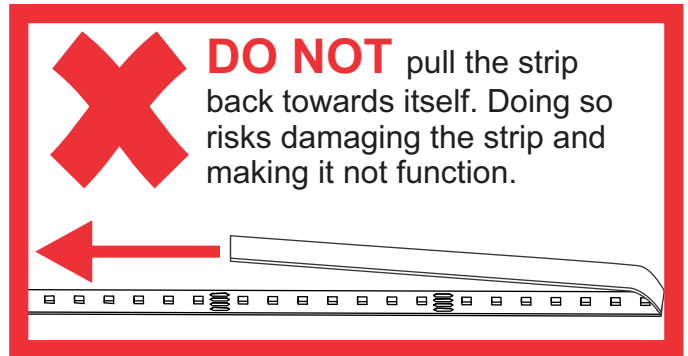
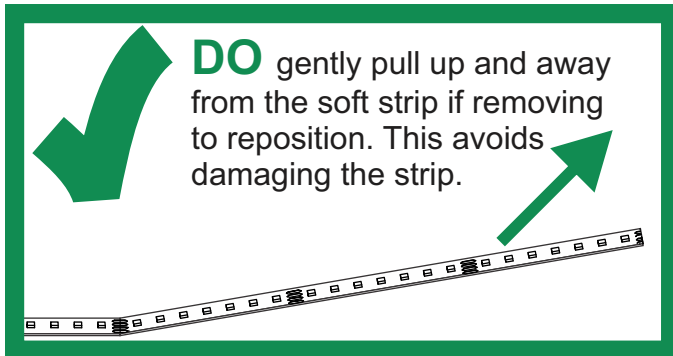

### Relocating Soft Strip (Optional)

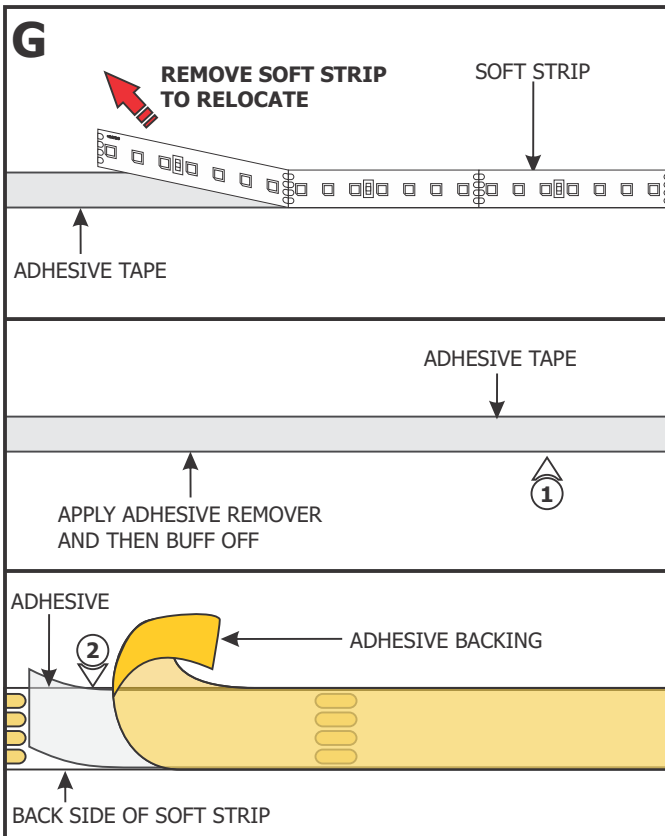

**NOTE:** If relocating the installed soft strip, make sure that the adhesive tape on back of the soft strip covers the entire strip. The adhesive tape isolates the strip from the installation surface. Damaged or inconsistent adhesive tape may cause the contacts on the back of the strip to come in contact with the conductive heat sink which will cause the strip to short and burn. Call PureEdge Lighting to get replacement adhesive tape and/or optional aluminum heat sink tape (SS-HR-F).

- 1:** To remove tape residue from back of the strip, apply WD-40, Goo Gone, or a mixture of warm water and lemon oil to the corner of a clean, dry towel. Gently buff the area containing the adhesive residue until it is completely removed.
- 2:** Gently remove a few inches from one side of the tape backing. Attach the adhesive tape to the back of the soft strip and apply moderate pressure to affix the tape. Continue this step a few inches at a time until the entire adhesive tape is attached to the back of the soft strip.
- 3:** Refer to Section Two to reinstall the soft strip.

# Wiring Diagram

