



1718 W. Fullerton Chicago, IL 60614  
 Ph: 773.770.1195 • Fax: 773.935.5613  
 www.PureEdgeLighting.com • info@PureEdgeLighting.com  
 © 2016 PureEdge Lighting. All Rights Reserved.

## Installation Instructions for **ST2A Stomp Strip 2.5W/ft 24VDC**, **ST5A Stomp Strip 5W/ft 24VDC** and **ST7A Stomp Strip 7.5W.ft** **24VDC, Snap and Light**

ST\_A-24V\_

### IMPORTANT INFORMATION

ETL LISTED



Intertek  
3028534

- Conforms to UL STD 1598 & UL STD 2108 Certified to CAN/CSA STD C22.2 NO 250.0
- Suitable for Under-Cabinet Mount
- Dry Location Only
- Use Only With Class 2 Power Unit
- Peut être fixé Sous Une Armoire
- Pour Emplacements Secs Seulement
- Utiliser Seulement Avec Classe 2 Unité d'alimentation électrique



**SAVE THESE INSTRUCTIONS!**

### Section One: Prepare the LED Stomp Strip

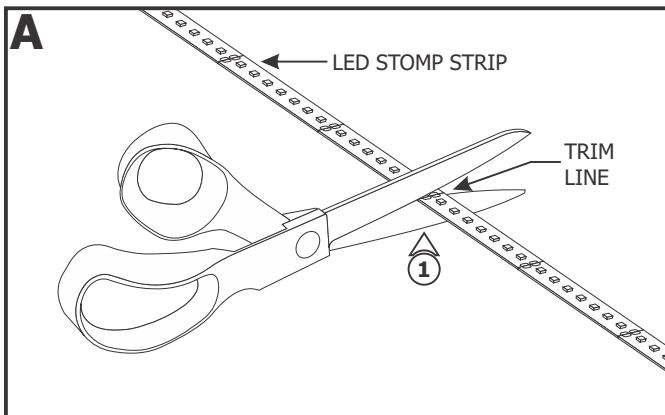

**1:** If necessary trim the Stomp Strip at the marked line above the contact (every 2.4" apart) with a sharp scissor to fit the design.

**NOTE:** Do not trim the strip over the sections that are joined together by soldering. The soldered contact will not connect to the Snap & Light connector easily.

**NOTE:** Do not trim the strip at unmarked sections which may cause that section of the strip not to light up.

**2:** Place the LED Stomp Strip on a flat, stable surface. Using a utility knife, carefully scrape the protective coating from the contacts.

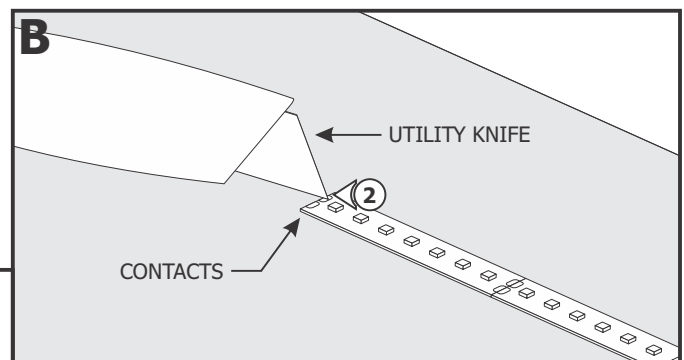

## Section Two: Install the Stomp Strip and Solderless Snap & Light Connectors

**C**

**1:** Align the +24VDC marking on the Stomp Strip with the red wires of the Snap & Light connector.

**2:** Center the Stomp Strip with the Snap & Light connector so that two Snap & Light contacts are aligned with one contact pad of the Stomp Strip and the other two contacts with the second contact pad.

**D**

**3:** Insert the exposed contacts at the end of the Stomp Strip under the Snap & Light contacts ensuring that the strip contacts are covered under the connector contacts.

**4:** Close the Snap & Light cover and ensure it snaps securely into place.

**E**

**Solderless Snap & Light Power/Jumper Connector (ST-SLC)**

**5:** When using the Snap & Light power jumper with another Stomp Strip, follow the steps in Section One; steps 1 through 4 in Section Two.

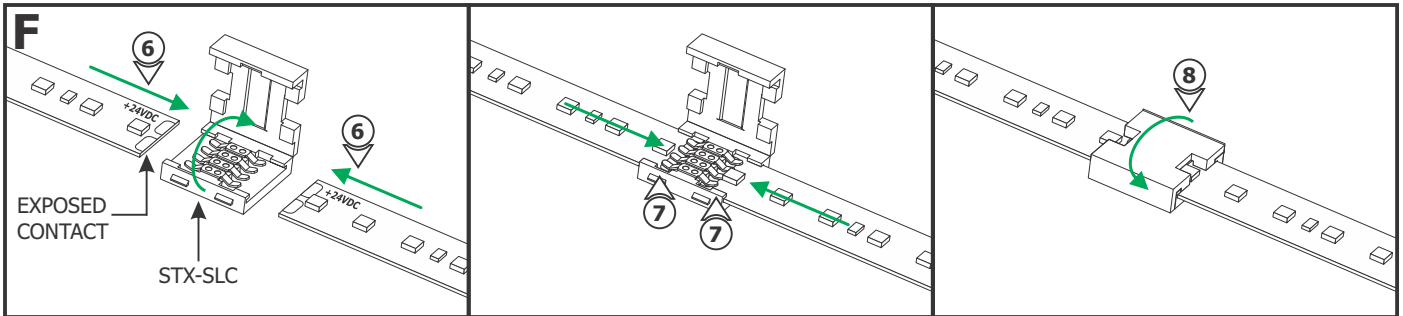

**Solderless Snap & Light Straight Joiner Connector (STX-SLC)**

- 6:** Open the Snap & Light Straight Joiner Connector. Align the Stomp Strips so that the +24VDC markings match. Center the Stomp Strip with the connector so that two Snap & Light contacts are aligned with one contact pad of the Stomp Strip and the other two contacts with the second contact pad.
- 7:** Insert the exposed contacts at the end of the Stomp Strips into the Snap & Light Straight Joiner Connector ensuring that the strip contacts are covered under the connector contacts.
- 8:** Close the Snap & Light cover and ensure it snaps securely into place.

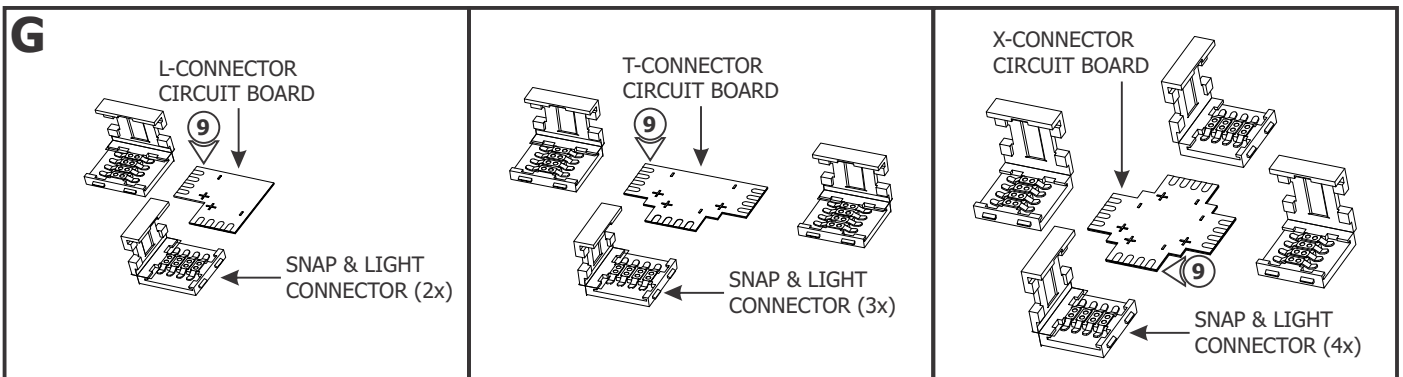

**Solderless Snap & Light L-Connector (STX-SLL), T-Connector (STX-SLT) and X-Connector (STX-SLX)**

- 9:** Open the Snap & Light Connectors. Slide one connector onto each arm of an L, T or X-Connector circuit board. Ensure the Snap & Light contacts are fully seated onto the circuit board.
- 10:** Align the positive and negative markings on each Stomp Strip section with the corresponding markings on the Snap & Light connector. Center the Stomp Strip with the connector so that two Snap & Light contacts are aligned with one contact pad of the Stomp Strip and the other two contacts with the second contact pad.
- 11:** Insert Stomp Strips completely into each Snap & Light Connector ensuring that the strip contacts are covered under the connector contacts.
- 12:** Close the Snap & Light covers and ensure they snap securely into place.

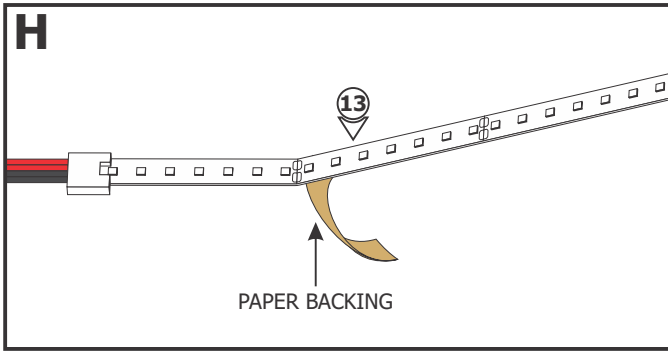

**13:** Carefully remove the backing from the Stomp Strip, make sure not to remove the tape from the Stomp Strip. Firmly press down the adhesive portion of the Stomp Strip onto the mounting surface while removing the rest of the backing, making sure there are no air bubbles that can cause surface irregularities.

**14:** Trim the other end of the Snap & Light connector when it is used as the power cord. Refer to the wiring diagrams and the instructions provided with the power supply to complete the installation.

**NOTE:** ST2A Stomp Strip consumes on average 2.5 Watt per foot.

**NOTE:** ST5A Stomp Strip consumes on average 5 Watt per foot.

**NOTE:** ST7A Stomp Strip consumes on average 7.5 Watt per foot.

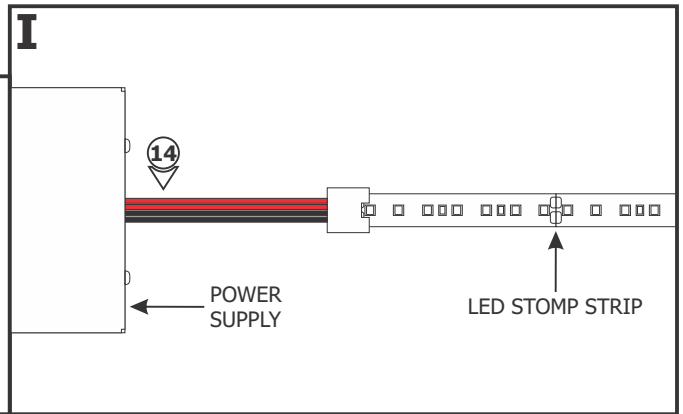

## General Wiring Diagram

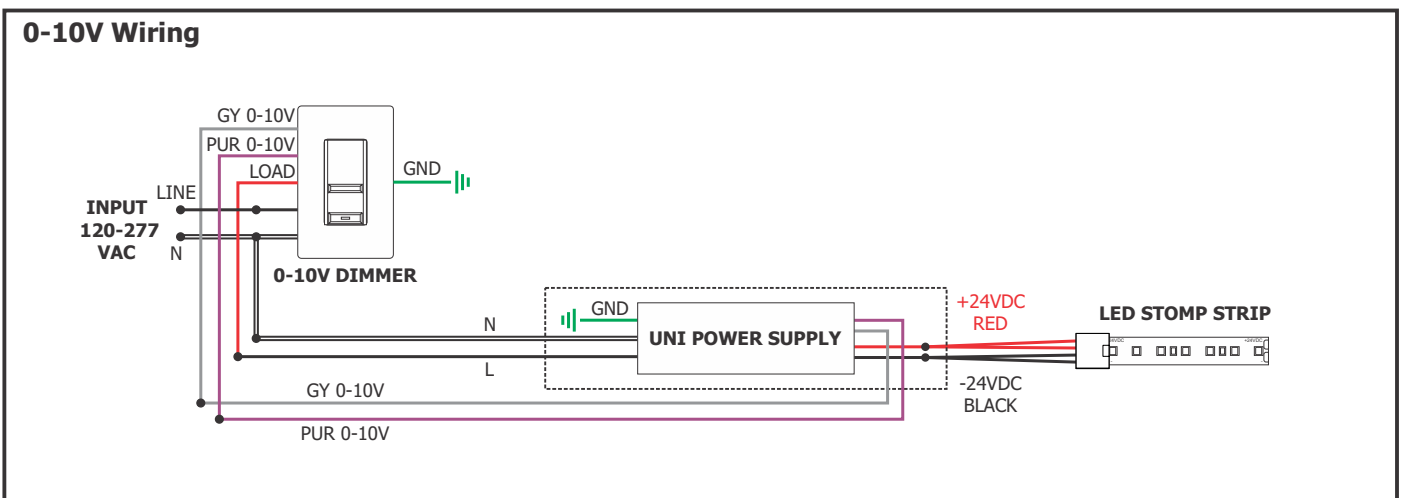
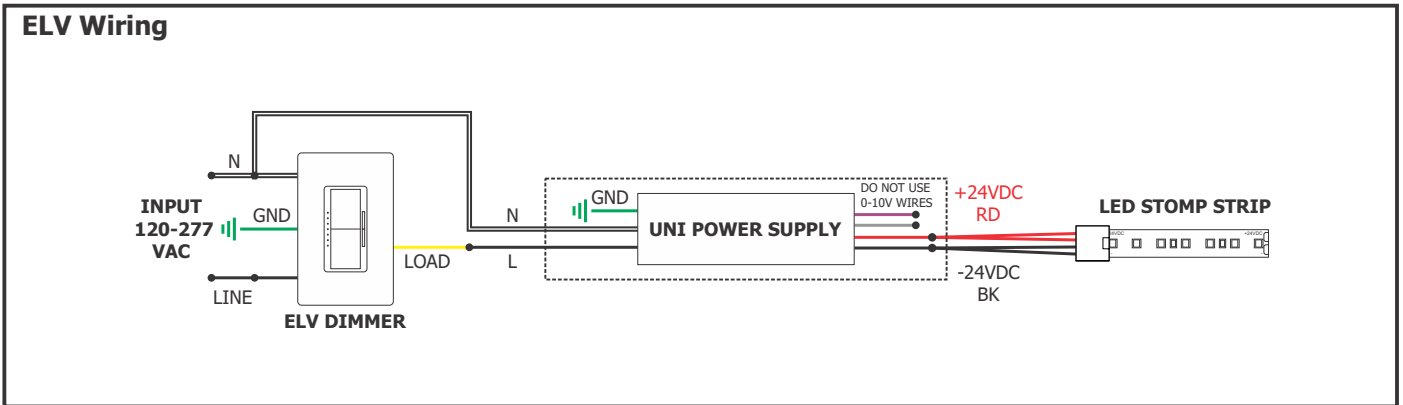

## IMPORTANT INFORMATION REGARDING INSTALLATION AND REWORK OF SOFT STRIP LED

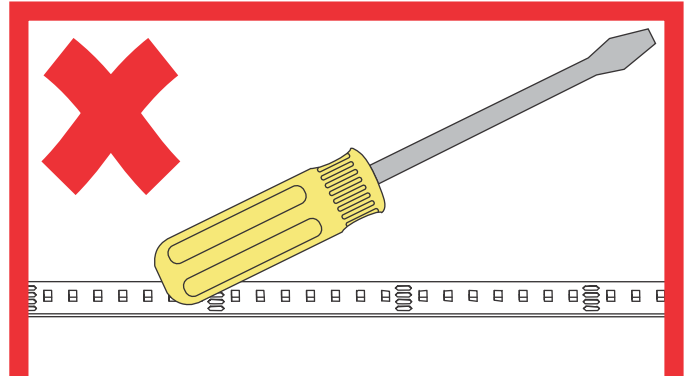
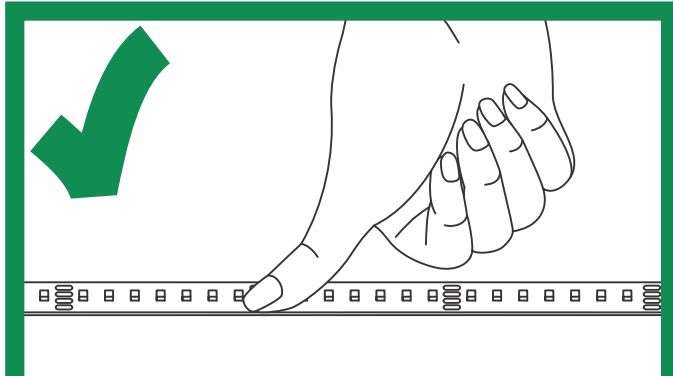
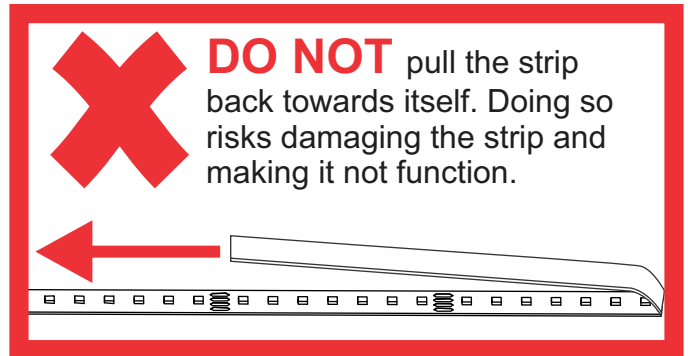
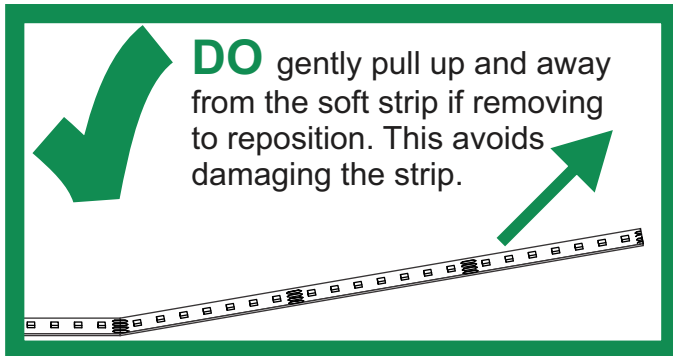

**DO** only ever use fingers to gently install soft strip to a surface **AFTER** cleaning the surface with alcohol.

**DO NOT** use any tool to install soft strip to a surface. This will damage the soft strip component.

### Relocating Soft Strip (Optional)

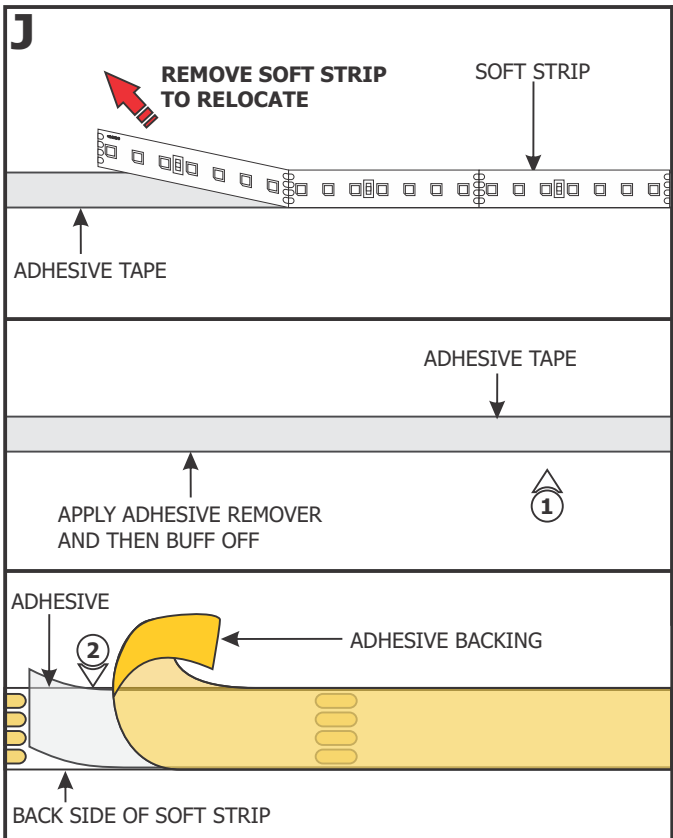

**NOTE:** If relocating the installed soft strip, make sure that the adhesive tape on back of the soft strip covers the entire strip. The adhesive tape isolates the strip from the installation surface. Damaged or inconsistent adhesive tape may cause the contacts on the back of the strip to come in contact with the conductive heat sink which will cause the strip to short and burn. Call PureEdge Lighting to get replacement adhesive tape and/or optional aluminum heat sink tape (SS-HR-F).

- 1:** To remove tape residue from back of the strip, apply WD-40, Goo Gone, or a mixture of warm water and lemon oil to the corner of a clean, dry towel. Gently buff the area containing the adhesive residue until it is completely removed.
- 2:** Gently remove a few inches from one side of the tape backing. Attach the adhesive tape to the back of the soft strip and apply moderate pressure to affix the tape. Continue this step a few inches at a time until the entire adhesive tape is attached to the back of the soft strip.
- 3:** Refer to Section Two to reinstall the LED strip.