



1718 W. Fullerton Chicago, IL 60614
 Ph: 773.770.1195 • Fax: 773.935.5613
 www.PureEdgeLighting.com • info@PureEdgeLighting.com
 © 2016 PureEdge Lighting. All Rights Reserved.

Installation Instructions for **2 X 60 Watt 24 Volt DC Power Supply with ELV Dimming**



SAVE THESE INSTRUCTIONS!



GENERAL INFORMATION

- **RISK OF FIRE:** This product must be installed by a qualified electrician. Turn the power to the electrical box off during installation. Read the "Important Safety Instructions " before installation.
- **NOTE:** To avoid overheating the power supply, install it in a ventilated remote location where air flows. Maintain proper spacing among power supplies when multiple power supplies are installed in the same remote location.
- This product is not suitable for wet locations. It is approved for the use at any height above the finished floor.
- A typical installation is shown. Specific installation must be in accordance with the local electrical codes.
- **TO REDUCE RISK OF FIRE,** it is important to wire the power supply for the system as described in this installation instruction.
- Load each power supply to **MAXIMUM 60** Watts.

IMPORTANT SAFETY INSTRUCTIONS

- Do not install this power supply in a wet location.
 - To reduce the risk of the system overheating and possibly causing a fire, make sure all the connections are tight.
 - Do not install *LED fixture closer than three inches or as specified in the *LED fixture installation instructions to curtains or similarly combustible materials. Keep insulation at least 3" away from the enclosure.
 - Turn the electrical power off before modifying the lighting system in any way.
 - For dimming options refer to EDGELIGHTING.COM.
- * See LED fixture installation instructions for proper placement.

Install the Power Supply

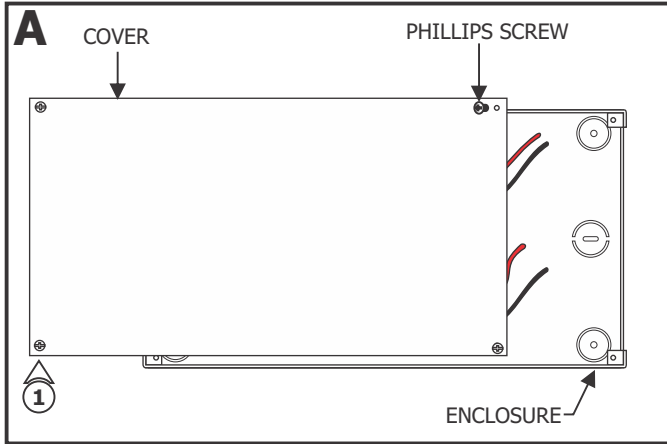

1: Loosen the four Phillips screws on the front of the power supply cover to slide the cover off of the enclosure.

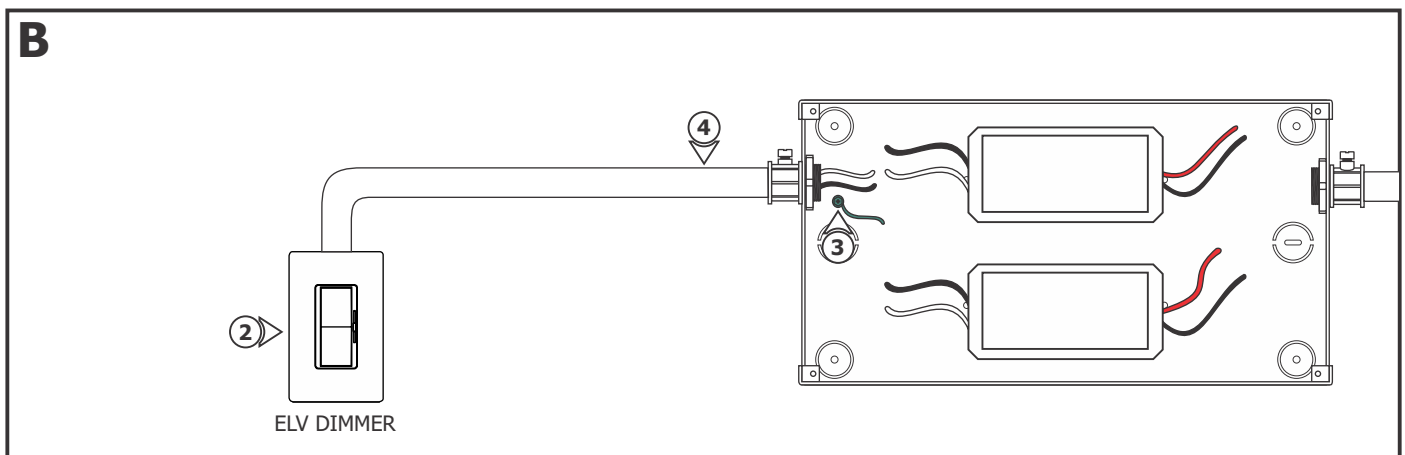

NOTE: This installation is shown with one dimmer. For separate controls, use multiple dimmers.

- 2:** Install the ELV dimmer and run the line voltage wires from the dimmer to the enclosure box. (Refer to the ELV dimmer instructions and wiring diagram on page 3 for more info.)
- 3:** Ensure that the power supply enclosure is grounded in accordance with local electrical codes.
- 4:** Remove knockouts from the power supply enclosure. Route the 120VAC hot and neutral wires from the ELV dimmer to the power supply enclosure.

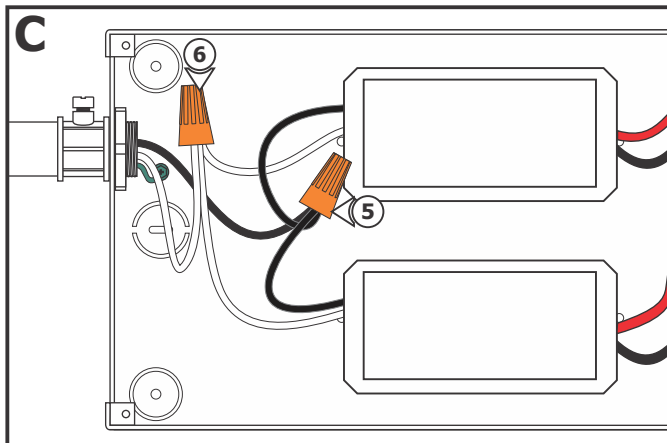

- 5:** Connect the 120VAC hot wire from the dimmer to the black wire of each power supply using a wire nut.
- 6:** Connect the 120VAC neutral wire from the dimmer to the white wire of each power supply using a wire nut.

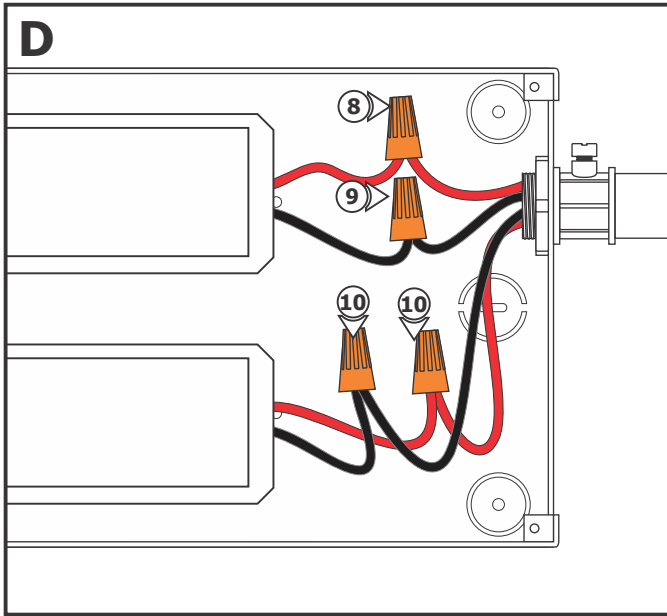

NOTE: Use only 24VDC LED products with this power supply.

NOTE: In order to use small gauge wires from the power supply to the LED fixture, it is recommended to install the power supply as near as possible to the LED fixture.

7: Use the "Low Voltage Wire Size Chart" below to determine the proper wire size connecting the power supply wires to the LED soft strip wires.

8: Connect the red (+24VDC) wire from one power supply to the red wires of one LED soft strip with a wire nut.

9: Connect the black (-24VDC) wire from the same power supply to the black wires of the same LED soft strip with a wire nut.

10: Repeat steps 8 and 9 for the other power supply and other LED soft strip.

11: Replace the power supply cover and secure it by tightening the four Phillips screws.

12: Turn on the power.

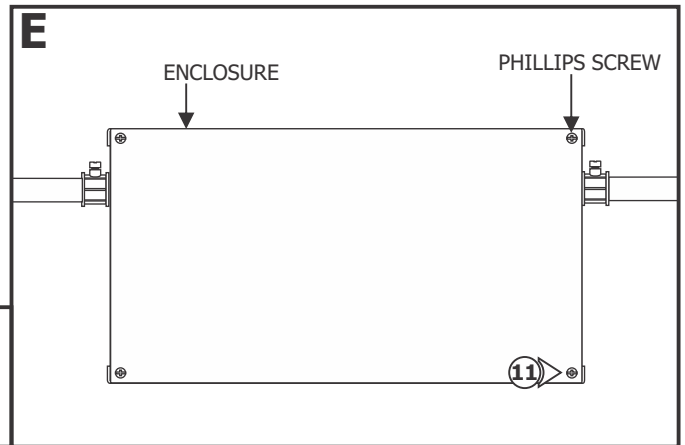

Wiring Diagram

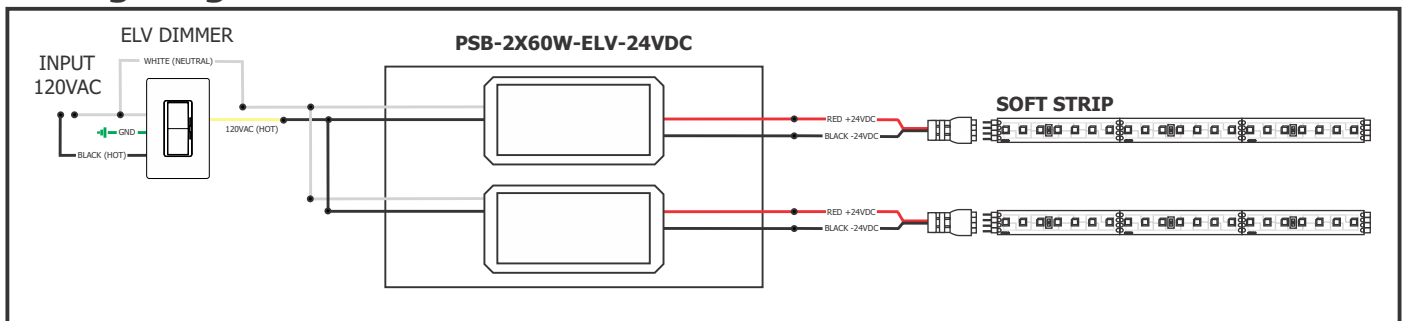

60W, 24VDC LOW VOLTAGE WIRE SIZE CHART

3% VOLTAGE DROP	WIRE LENGTH IN FT	UP TO 53FT	54FT - 82FT	83FT - 137FT
	WIRE SIZE	14 AWG	12 AWG	10 AWG
	VOLTAGE AT END OF THE WIRE	23.28 VDC	23.29 VDC	23.28 VDC