

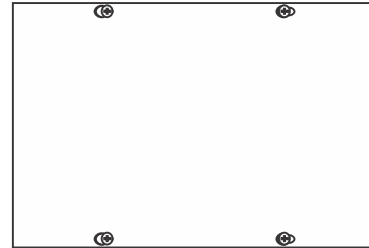

1718 W. Fullerton Chicago, IL 60614
 Ph: 773.770.1195 • Fax: 773.935.5613
 www.PureEdgeLighting.com • info@PureEdgeLighting.com
 © 2016 PureEdge Lighting. All Rights Reserved.

Installation Instructions for **200 Watt 24 Volt DC RGB DMX LED Power Supply**



SAVE THESE INSTRUCTIONS!

GENERAL INFORMATION

- **RISK OF FIRE:** This product must be installed by a qualified electrician. Turn the power to the electrical box off during installation. Read the "Important Safety Instructions " before installation.
- **NOTE:** To avoid overheating the power supply, install it in a ventilated remote location where air flows. Maintain proper spacing among power supplies when multiple power supplies are installed in the same remote location.
- This product is not suitable for wet locations. It is approved for the use at any height above the finished floor.
- A typical installation is shown. Specific installation must be in accordance with the local electrical codes.
- **TO REDUCE RISK OF FIRE,** it is important to wire the power supply for the system as described in this installation instruction.
- Load the power supply to **MAXIMUM 200** Watts.
- Use CDP color dial or CTP color touch screen controller with RGB LED soft strip.

IMPORTANT SAFETY INSTRUCTIONS

- Do not install this power supply in a wet location.
- To reduce the risk of the system overheating and possibly causing a fire, make sure all the connections are tight.
- Do not install *LED fixture closer than three inches or as specified in the *LED fixture installation instructions to curtains or similarly combustible materials. Keep insulation at least 3" away from the enclosure.
- Turn the electrical power off before modifying the lighting system in any way.
- * See LED fixture installation instructions for proper placement.

WARNING: This power supply is equipped with a cooling fan. Do not run the power supply in a dusty environment. All drywall finish and sanding must be done prior to using the power supply. Dust particles may stop the fan from working & eventually destroy the power supply.

200W, 24VAC LOW VOLTAGE WIRE SIZE CHART

3% VOLTAGE DROP	WIRE LENGTH IN FT	UP TO 16FT	17FT-24FT	25FT-41FT	42FT-62FT	63FT-98FT
	WIRE SIZE	14 AWG	12 AWG	10 AWG	8 AWG	6 AWG
	VOLTAGE AT END OF THE WIRE	23.29 VAC	23.31 VAC	23.28 VAC	23.29 VAC	23.28 VAC

100W, 24VAC LOW VOLTAGE WIRE SIZE CHART (PER RUN)

3% VOLTAGE DROP	WIRE LENGTH IN FT	UP TO 31FT	32FT-49FT	50FT-81FT	82FT-124FT
	WIRE SIZE	14 AWG	12 AWG	10 AWG	8 AWG
	VOLTAGE AT END OF THE WIRE	23.3 VAC	23.3 VAC	23.3 VAC	23.3 VAC

Installing LED Power Supply with RGB Soft Strip & CDP or CTP Controller

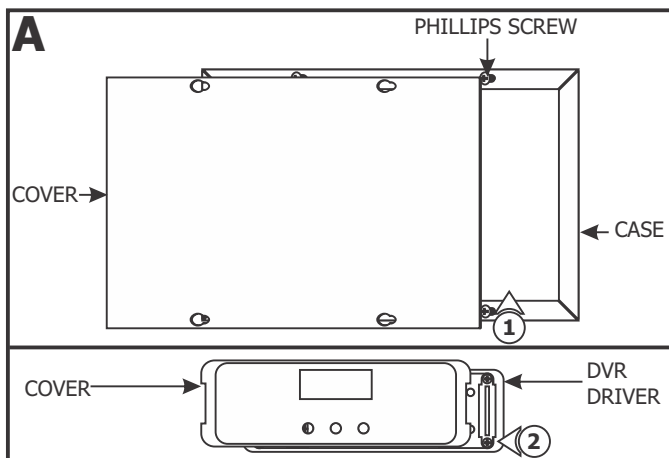

1: Loosen the four Phillips screws on the front of the power supply cover to slide the cover off of the case.

2: Carefully pull off the cover from the DVR-RGB-200 driver.

NOTE: Use a deep double gang boxes to fit the controller and controller power supply (OT-20-120-240-245 recommended).

NOTE: Refer to the "Configuring DimWheel" & "Operating DimWheel" on page 6 & 7 to properly operate the controller.

- 3:** Connect one end of a red wire to "VDC+" of the controller terminal and the other end of the red wire to the "+24VDC" of the power supply terminal.
- 4:** Connect one end of a black wire to "Ground" of the controller terminal and the other end to the "-24VDC" of the power supply terminal.
- 5:** Run the black and white line voltage wires coming from the controller power supply to the power supply case.
- 6:** Connect the white wire to "N" terminal of the controller power supply.
- 7:** Connect the black wire to "L" terminal of the controller power supply.
- 8:** Install conduits from controller, main panel (line voltage), and soft strip to power supply.
- 9:** Run proper DMX cable (**Belden #9841 recommended**) with three data wires from controller to the power supply box.

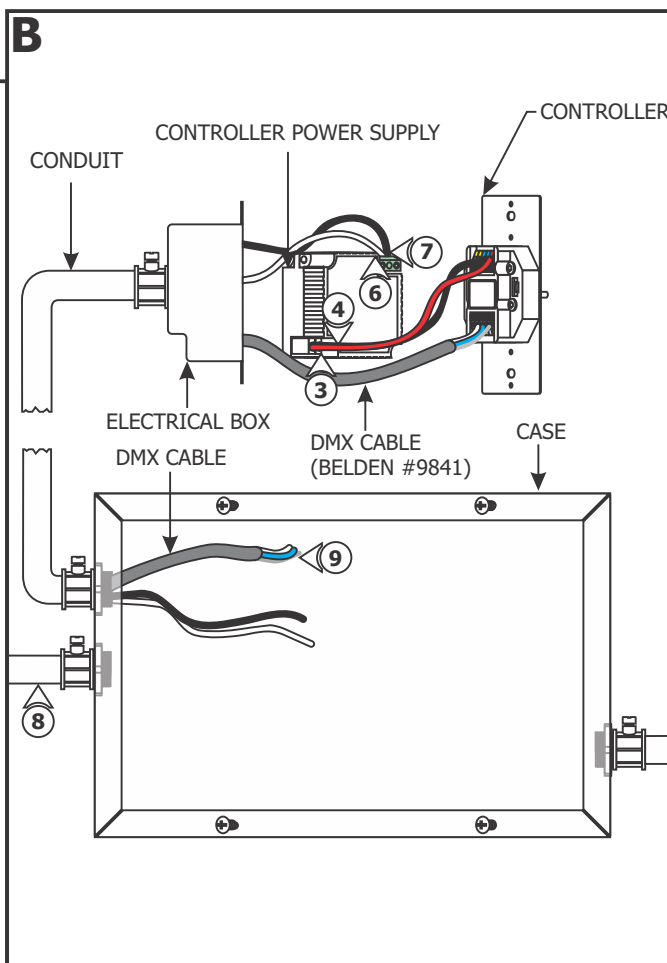

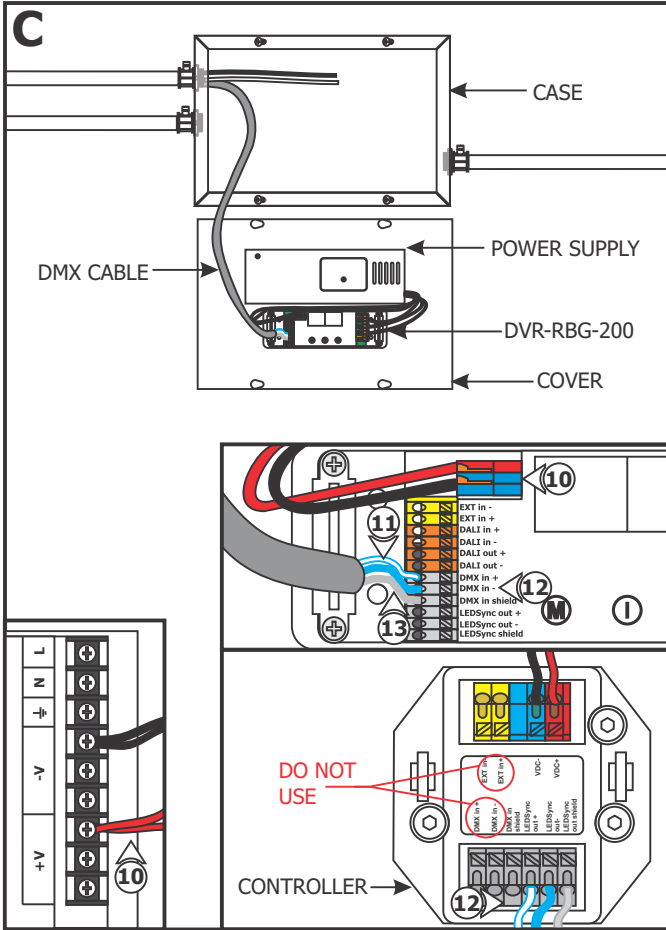

10: Install a red wire from the power supply "+V" terminal to DVR-RGB-200 "VDC+" red terminal and a black wire from power supply "-V" terminal to DVR-RGB-200 "VDC-" blue terminal.

11: Connect one end of a data wire (blue with white stripes wire) to controller "LEDSYNC OUT-" terminal. Connect the other end into the DVR-RGB-200 "DMX in -" terminal.

12: Connect one end of a data wire (white with blue stripes wire) to controller "LEDSYNC OUT+" terminal. Connect the other end into the DVR-RGB-200 "DMX+" terminal.

13: Connect one end of a data wire (bare shield wire) to controller "LEDSYNC SHIELD" terminal. Connect the other end into the DVR-RGB-200 "DMX in shield" terminal.

NOTE: "DMX in+", "DMX in-", "EXT in+" & "EXT in-", controller terminals are not used on controller.

- 14:** Run the line voltage power wires into the power supply.
- 15:** Connect the black power wire and the black controller wire to the "L" terminal of the power supply.
- 16:** Connect the white power wire and the white controller wire to the "N" terminal of the power supply.
- 17:** Make sure the power supply ground terminal is grounded in accordance with local electrical codes.
- 18:** Connect three black wires to the DVR-RGB-200 "GROUP 1 GND", "GROUP 2 GND", and "GROUP 3 GND" black terminal to the power supply "-V" terminal.

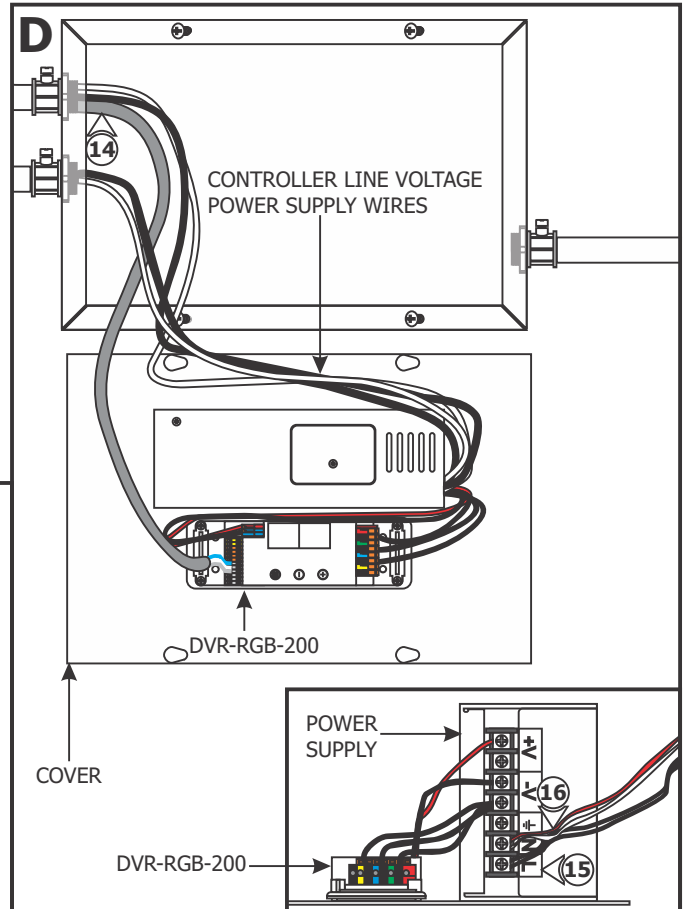

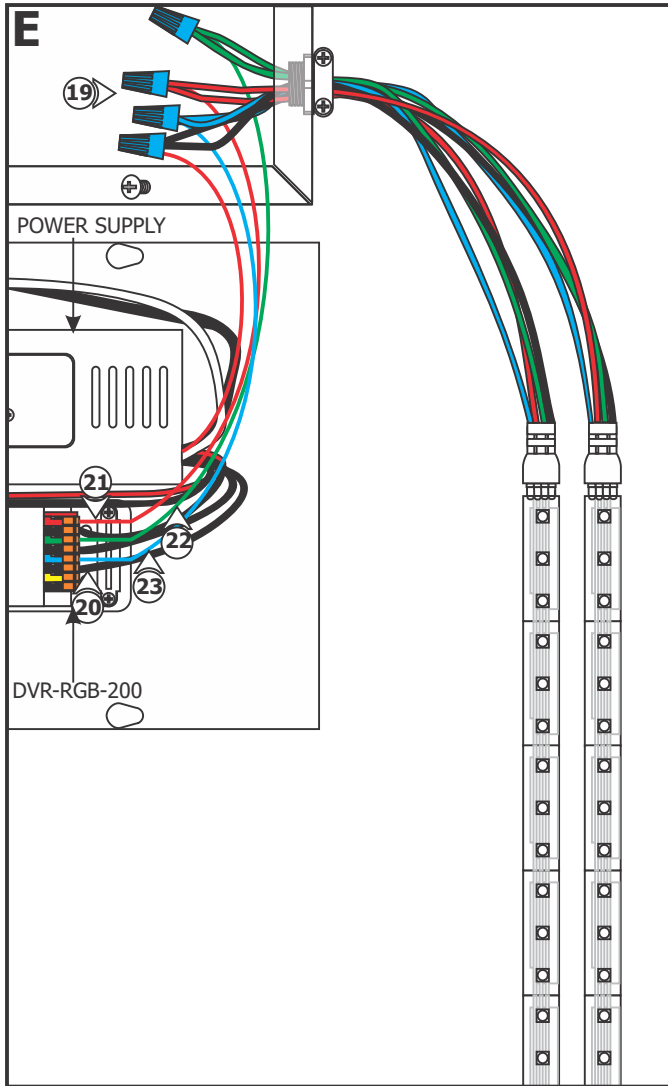

NOTE: The DVR-RGB-200 terminals adapt maximum 18 AWG size. To avoid voltage drop, use 6" of 18 AWG size in RGB terminals connected inline to proper size gauge wire attached to the RGB LED wires with wire nuts. See the "Low Voltage Wire Size Chart" on page 1.

19: Use the "Low Voltage Wire Size Chart" on page 1 to determine proper wire size connecting to the DVR-RGB-200 terminals.

20: Run the proper size green, red, blue, and black wires from the RGB LED soft strip to the power supply case.

NOTE: This power supply is for multiple runs. Do not exceed the maximum wattage of the power supply.

NOTE: Use only 24 volt RGB LED soft strip with this power supply.

21: Connect the soft strip black wire into power supply "+V" terminal. Connect the other end to RGB soft strip black wire(s).

22: Connect the soft strip red wire into DVR "Group 1-" red terminal. Connect the other end to RGB soft strip red wire(s).

23: Connect the soft strip green wire into DVR "Group 2-" green terminal. Connect the other end to RGB soft strip green wire(s).

24: Connect the soft strip blue wire into DVR "Group 3-" blue terminal. Connect the other end to RGB soft strip red wire(s).

25: Replace the DVR-RGB-200 cover.

26: Replace the power supply cover and secure it by tightening the four Phillips screws.

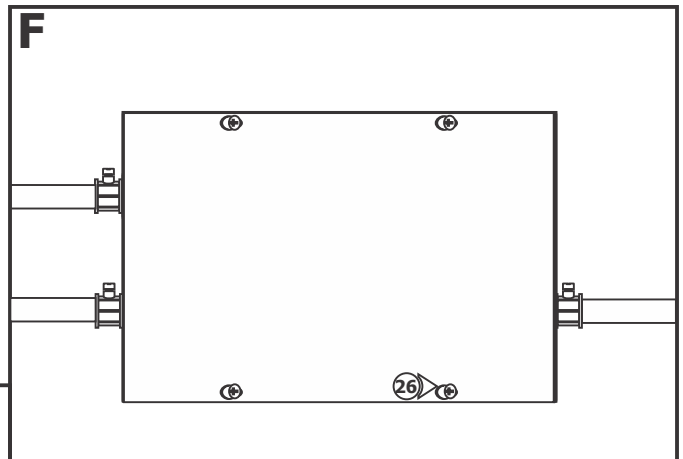

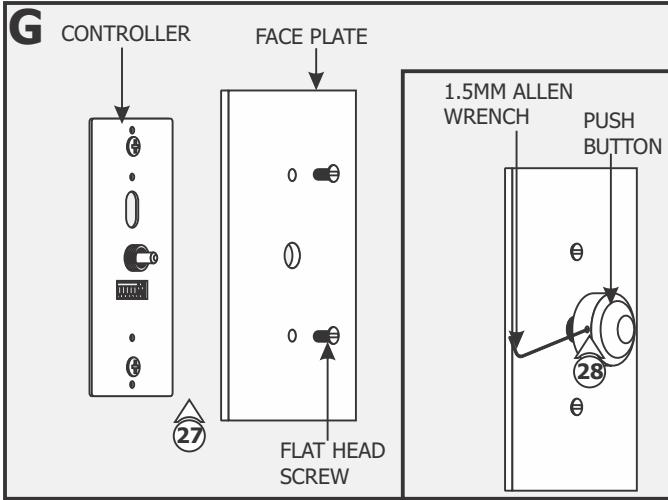

27: Align the face plate to the controller and secure using the two flat head screws.

28: Attach the push button onto the controller center rod and secure by tightening the M3 set screw with the 1.5mm Allen wrench provided.

Using LED Power Supply with RGB Soft Strip & CDP or CTP Control

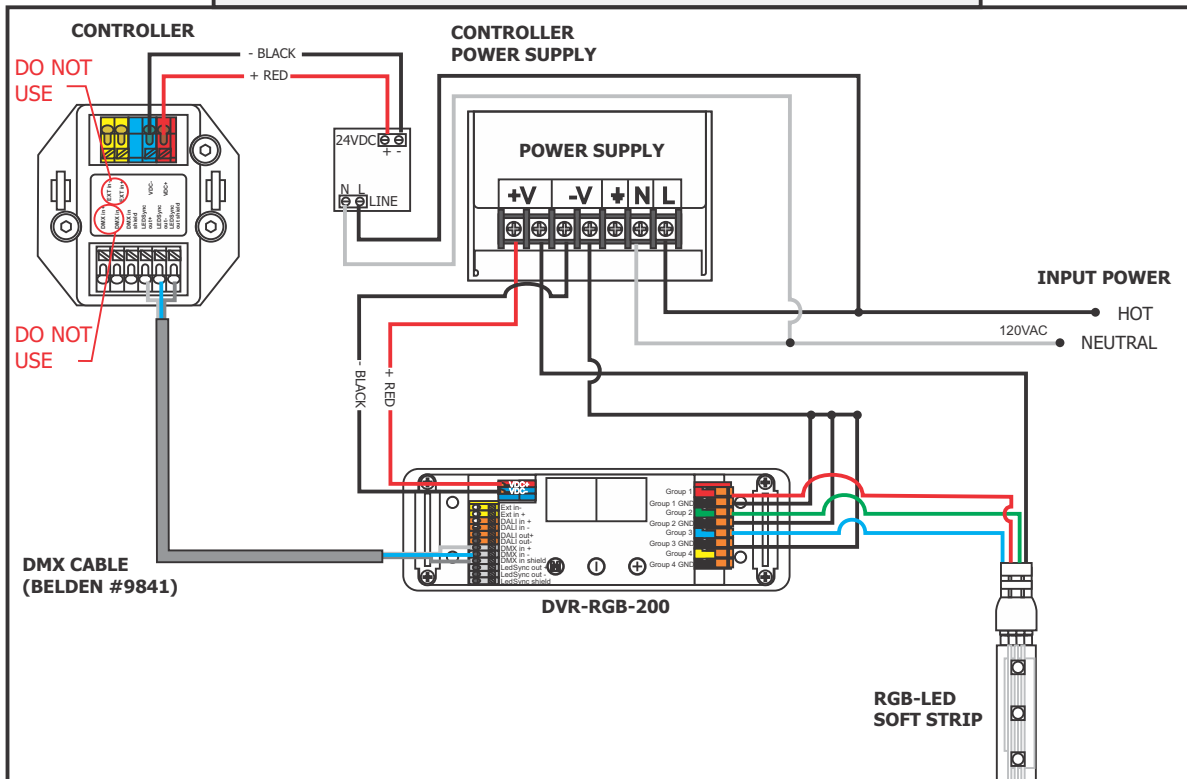

Selecting Modes

Configure your CDP by setting the DIP switches on the front:



NOTE: The DIP switches must remain accessible after installation. When making changes in the DIP switch settings, disconnect and reconnect the power supply to activate new settings.

Operating CDP

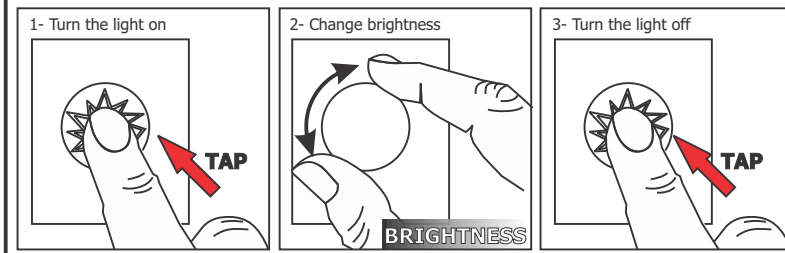

Advanced Operation for Color Mode

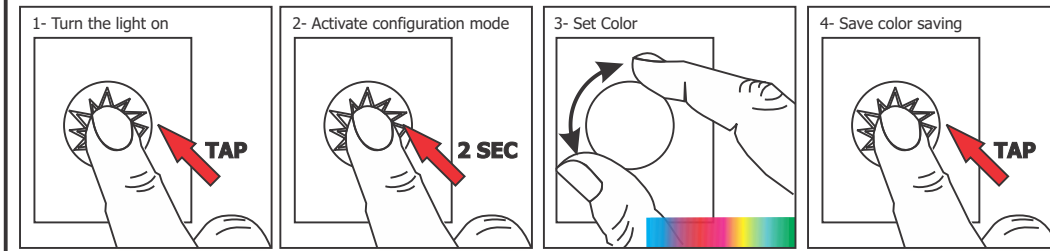

Advanced Operation for Chase Mode

