



1718 W. Fullerton Chicago, IL 60614
 Ph: 773.770.1195 • Fax: 773.935.5613
 www.PureEdgeLighting.com • info@PureEdgeLighting.com
 © 2016 PureEdge Lighting. All Rights Reserved.

Installation Instructions for Pipeline Stem Mounted Straight Run Table Mount with Feed Through 2" Canopy - Remote Power

P__-TP__

IMPORTANT INFORMATION

- This instruction shows a typical installation.
- This product is wall and table top mount.
- It is recommended more than one person assist in this installation.

SAVE THESE INSTRUCTIONS!

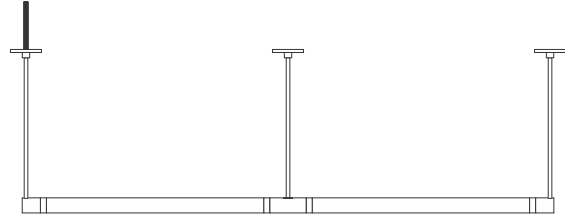

Section One: Resize the Stem (Optional)

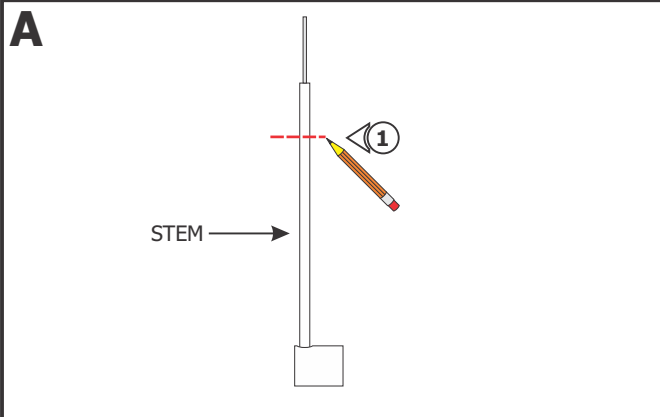

NOTE: Adjust the height of the stem. Omit this section if adjustments are not needed.

- 1:** From the end of the power feed stem, mark the stem to the amount that needs to be shorten. For example, to resize 24" stem to 17", mark 7" from the end of the power feed stem.

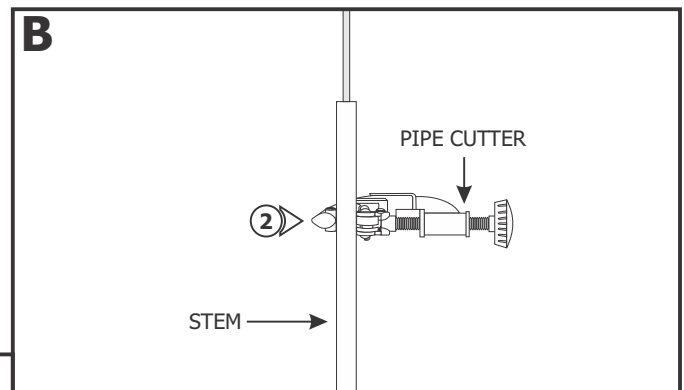

- 2:** Use a pipe cutter to cut out the excess rod.

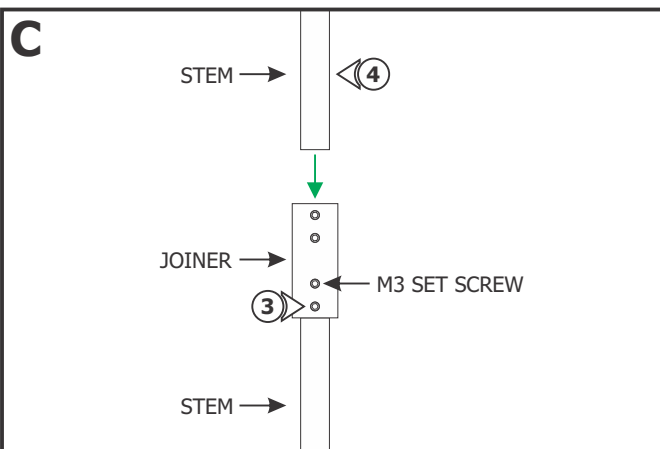

- 3:** To extend the rod, insert the stem half way into the joiner. Tighten the M3 set screws using a 1.5mm Allen wrench.

- 4:** Slide the other stem into the joiner and tighten the remaining set screws.

- 5:** Refer to steps 1 and 2 to cut the stem to desired length.

Section Two: Assemble the fixture

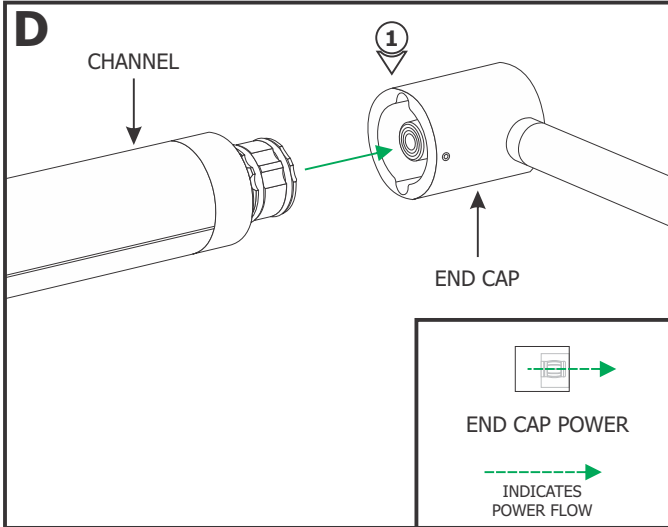

NOTE: Omit this section if the fixture is fully assembled.

1: Align the channel with the stem end cap and slide into place.

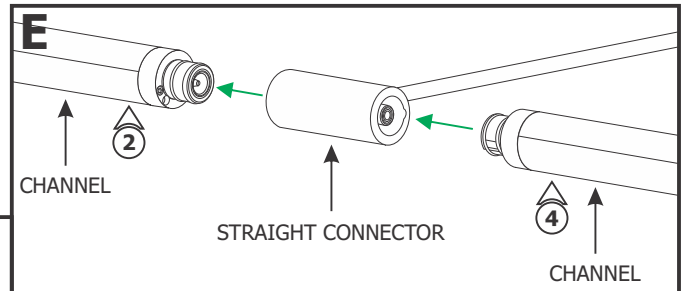

NOTE: Omit steps 2 through 4 if the fixture does not come with Straight Connector(s).

- 2:** The Straight Connector conducts power in one direction (left or right) or both directions.
- 3:** Depending on the design, ensure the conductive end of the Straight Connector is facing the correct direction.
- 4:** Snap the other end of the modular channel into the Straight Connector. Repeat these steps for all other Straight Connectors and remaining modular channels.

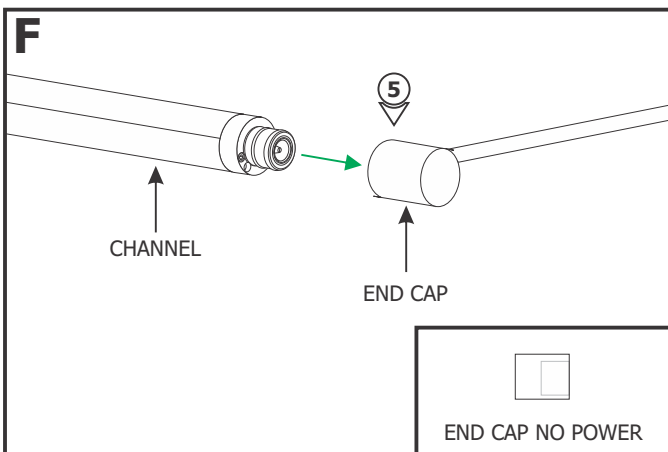
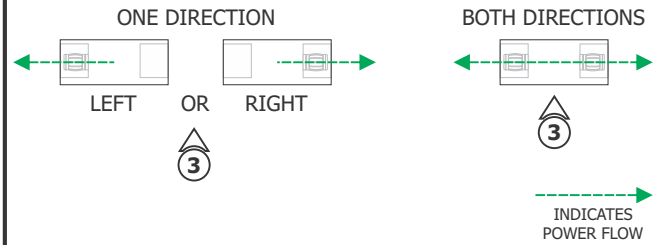

5: Snap the last channel to the last End Cap.

- 6:** Rotate each channel to the desired angle.
- 7:** Secure the channels by tightening the #4-40 set screws using a 0.05" Allen wrench.

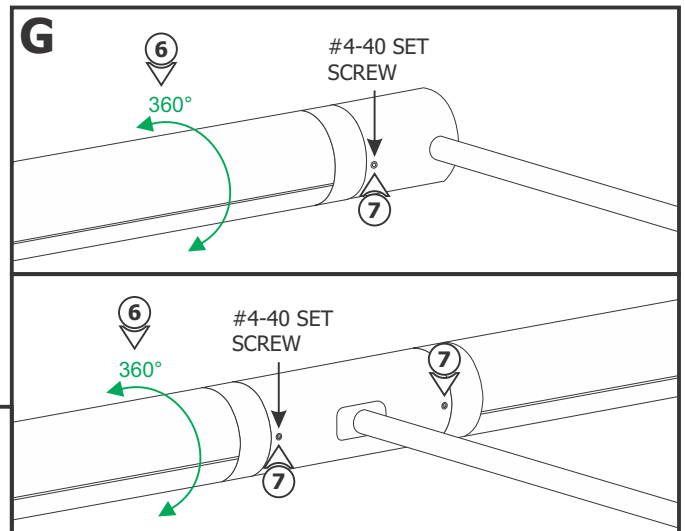

Section Three: Lay Out the Fixture and Install the Base

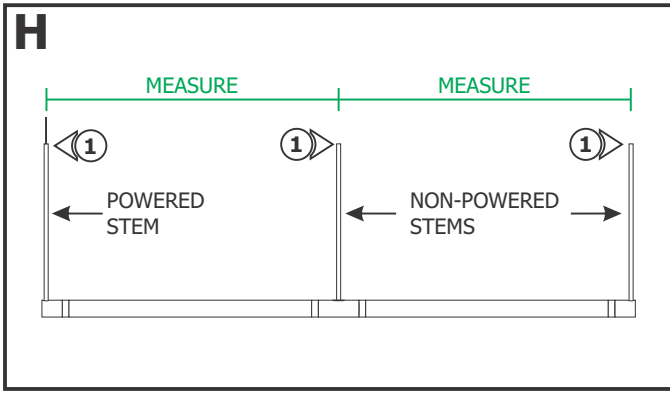

1: Measure the distance between the center of each stem.

2: Mark the measured points on the surface. Ensure the marked points are leveled horizontally.

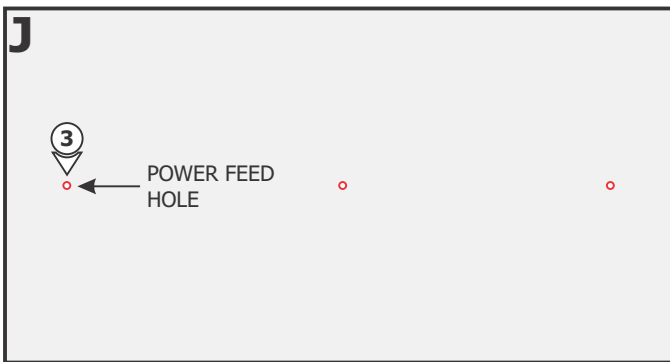
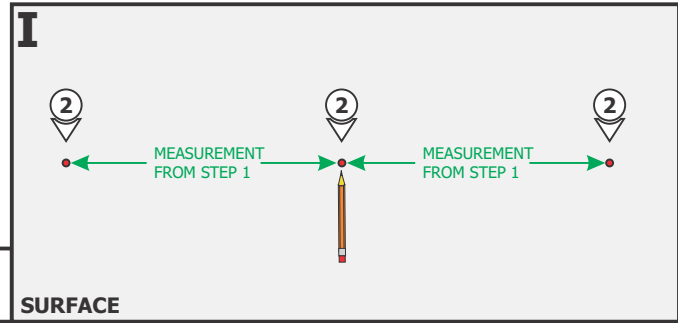

3: Using a 7/16" bit, drill out the power feed hole through the front & back surfaces.

4: Center each base with the marked points and mark two additional locations through the holes.

NOTE: The base holes should be in a vertical position at 90° angle to the direction of the fixture.

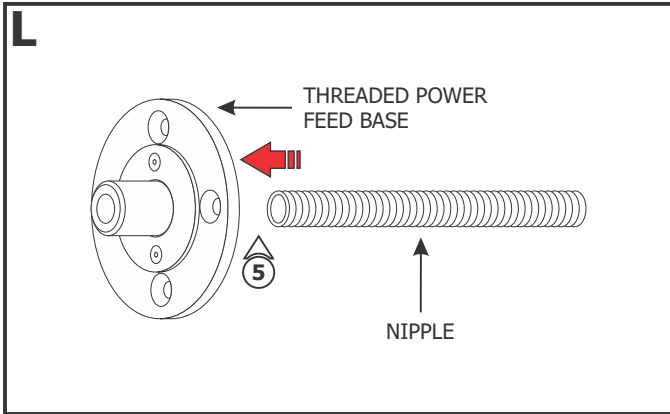
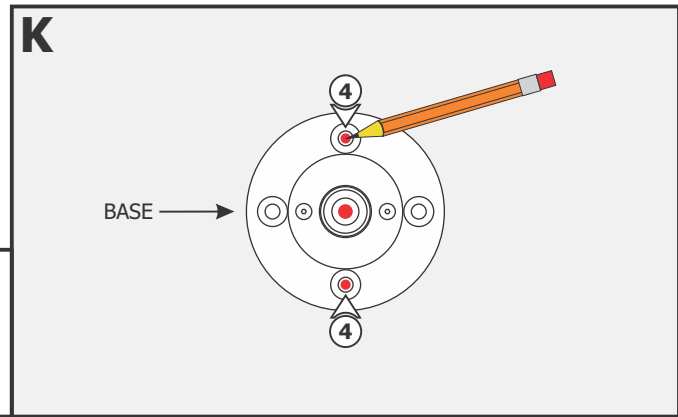

5: For the threaded Power Feed Base, insert and tighten the nipple into the back of the base.

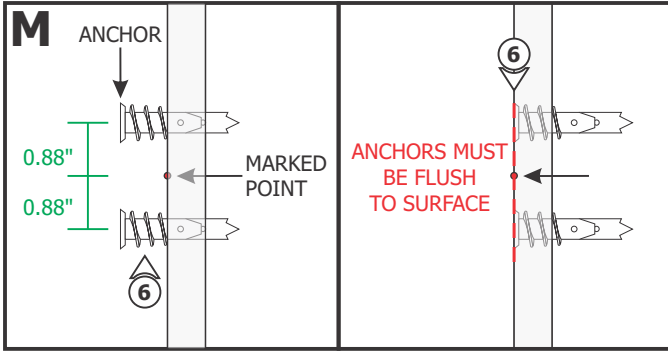

NOTE: Omit step 6 if mounting directly to a wood surface.

6: Tap the anchors to the new marked points with a hammer up to the threaded portion. Screw in the threaded portion of the anchors with a Phillips screw driver.

7: For the threaded Power Feed Base, insert the nipple into the hole.

8: Secure the bases to the anchors with two provided #8 screws.

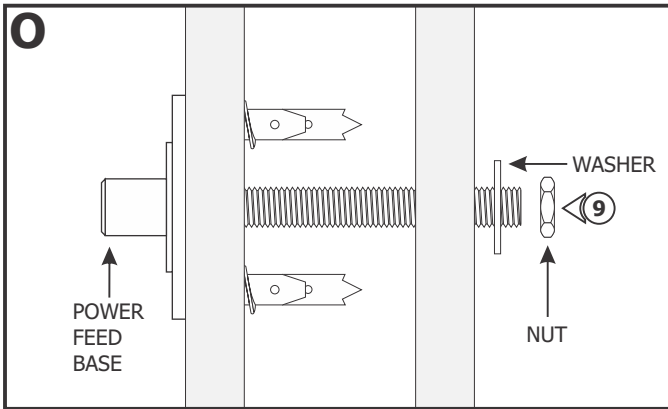
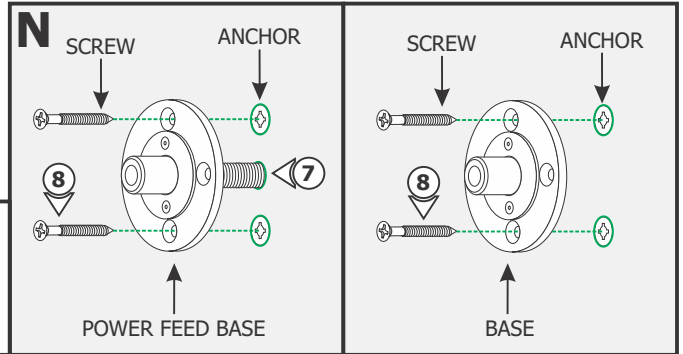

9: Secure the nipple from behind the surface using the large washer and nut.

Section Four: Install Cantilevers

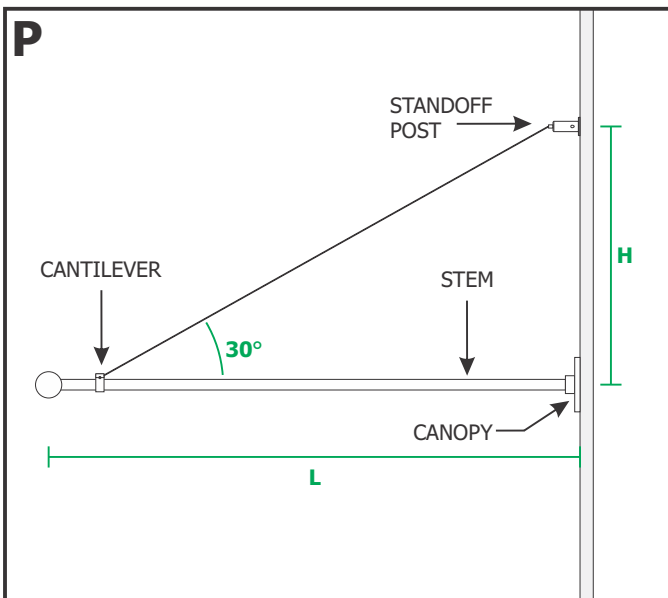

NOTE: Omit this section if the stem length is 14" and less and no cantilever is used.

1: The standoff post should be above the canopy at a minimum of 30° angle between the stem and the cable to properly lock the cable position in place.

2: Use the tables below to determine the standoff post position relative to the canopy for various angles.

ANGLE	EQUATION FOR HEIGHT (H)
30°	$H = 0.6 \times L$
45°	$H = L$
60°	$H = 1.7 \times L$

EXAMPLE

LENGTH (L)	(H) FOR 30°	(H) FOR 45°	(H) FOR 60°
36"	21"	36"	62"
24"	14"	24"	42"

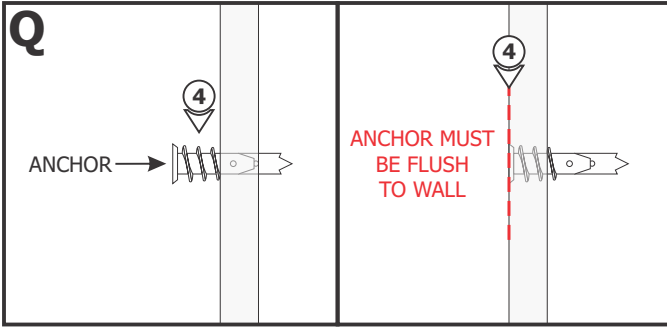

3: Mark out the cantilever location on the wall.

NOTE: Omit step 4 if mounting directly to a wood surface.

4: Tap the anchor to the marked point with a hammer up to the threaded portion. Screw in the threaded portion of the anchors with a Phillips screw driver.

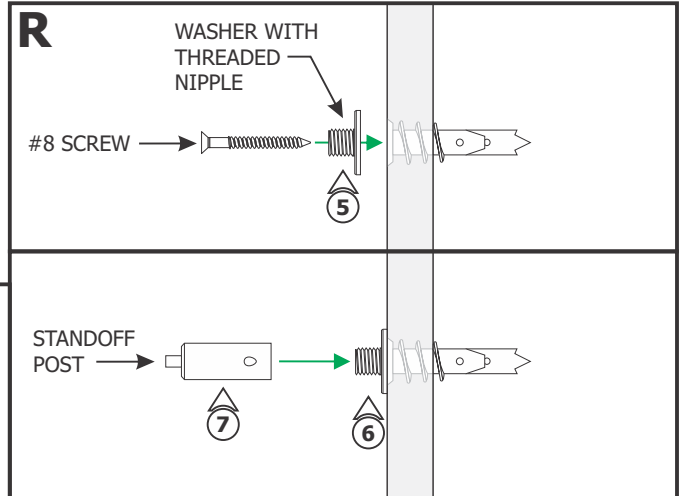

5: Feed the #8 screw through the washer with threaded nipple into the anchor.

6: Tighten the #8 screw completely into the anchor.

7: Tighten the standoff post completely onto the threaded nipple.

Section Five: Install the Fixture

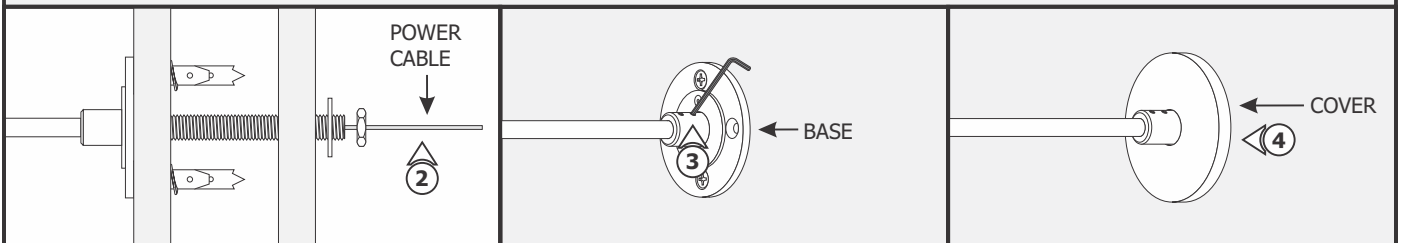
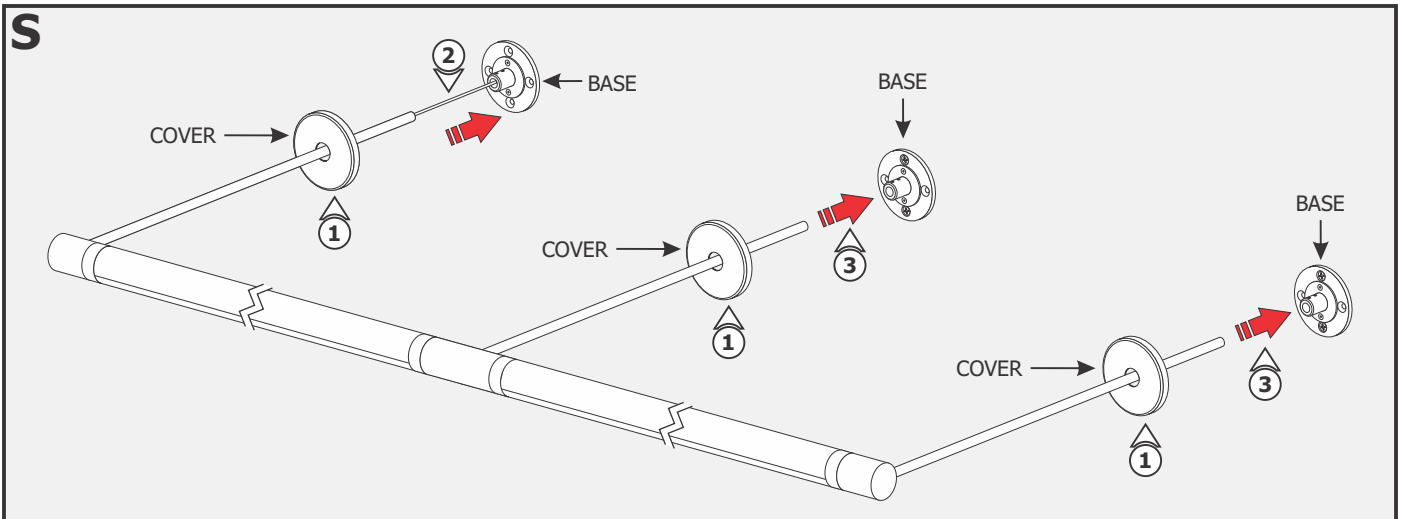

1: Slide the canopy covers over the stems.

2: Feed the power coaxial cable coming out of the stem through the base and nipple.

3: Align and insert the stems completely into the bases. Secure the stems by tightening the #6-32 set screws with the 1/16" Allen wrench.

4: Slide the covers over the bases. The magnets on the back of the cover will keep the canopy in place.

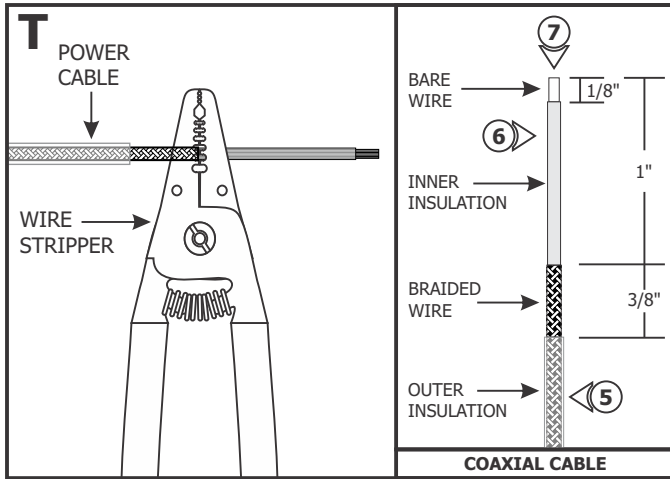

NOTE: Scan the QR Code to watch the video clip of the following steps or visit https://www.PureEdgeLighting.com/video_feed/installation_cxc_connector

- 5:** Use the 18AWG hole of the wire stripper to remove 1-3/8" of the outer insulation to expose the braided wire.
- 6:** Use the 18AWG hole of the wire stripper to remove 1" of the braided wire making sure not to nick the inner wire insulation.
- 7:** Use the 20AWG hole of the wire stripper to remove 1/8" of the inner insulated wire.

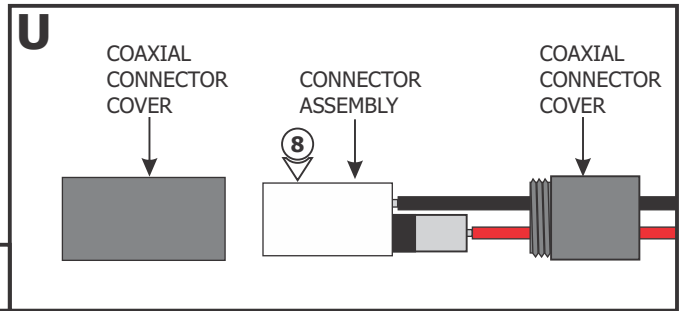

- 8:** Unscrew the coaxial connector covers and remove from the connector assembly.

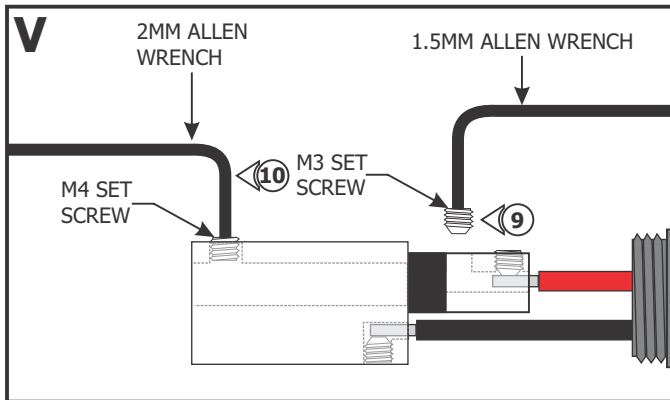

- 9:** Using the provided 1.5mm Allen wrench, remove the M3 set screw from the coaxial connector assembly.
- 10:** Using the provided 2mm Allen wrench to loosen (do not remove) the M4 set screw.

- 11:** Slide the connector cover over the coaxial cable.
- 12:** Place the ferrule over the 3/8" braided wire of the coaxial cable.

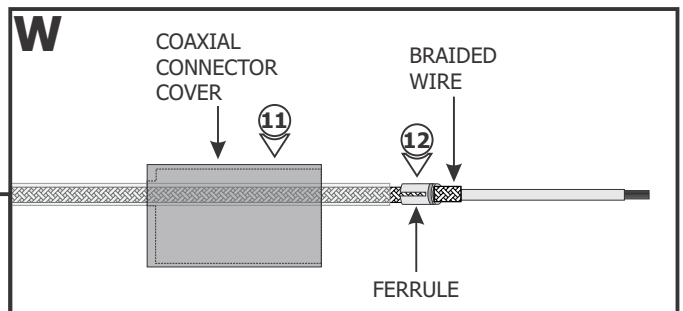

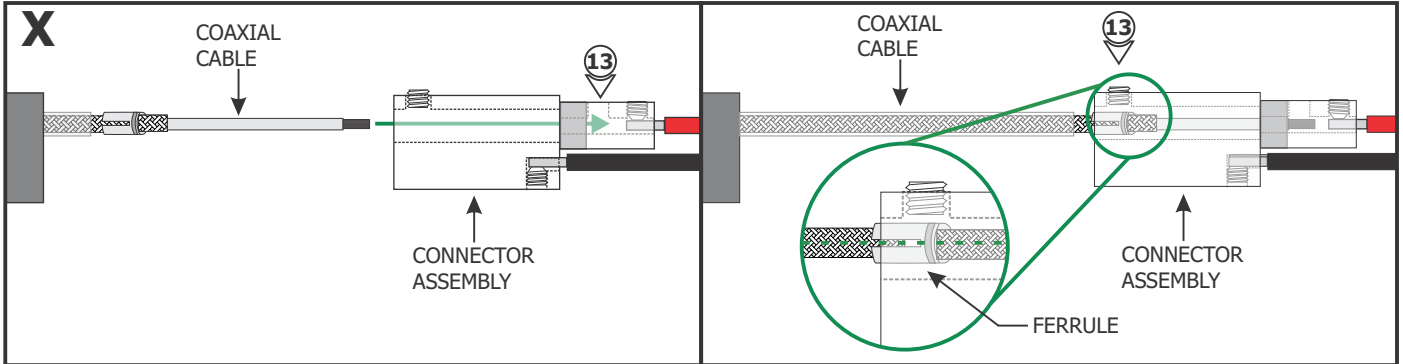

13: Insert the coaxial cable into the coaxial connector until the wires of the center conductor are visible through the M3 set screw hole.

NOTE: Ensure that the split in the ferrule is aligned 90° from the M4 set screw (see inset).

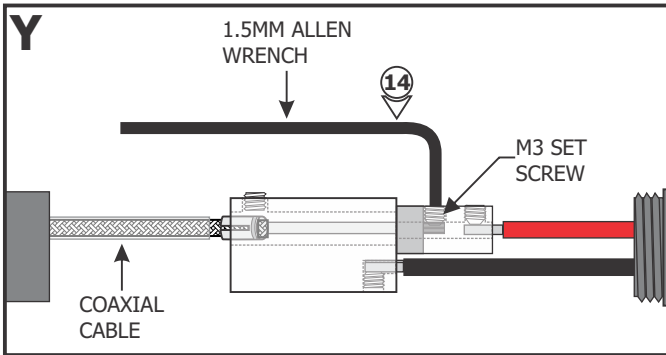

14: Use the provided 1.5mm Allen wrench to replace and securely tighten the M3 set screw.

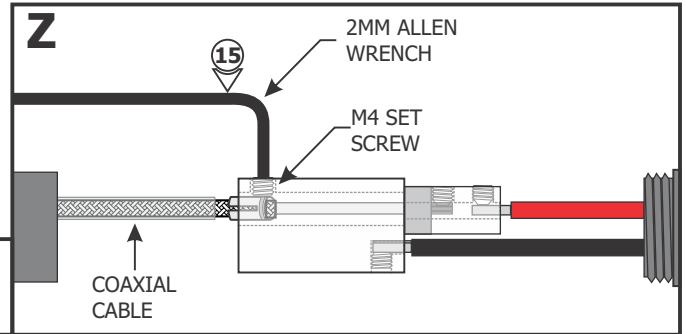

15: Use the provided 2mm Allen wrench to securely tighten the M4 set screw until it squeezes the wire ferrule tightly to the coaxial cable.

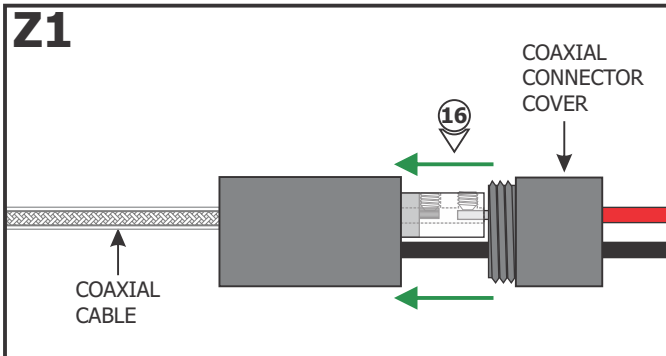

16: Replace the coaxial connector cover and tighten into place.

NOTE: The 24VDC power wires must be present in the junction box. Refer to the installation instructions provided with the power supply.

NOTE: It is recommended another person hold the fixture while the electrician connects the power to the fixture.

17: Connect the red fixture wire to the +24VDC power supply wire with a wire nut.

18: Connect the black fixture wire to the -24VDC power supply wire with a wire nut.

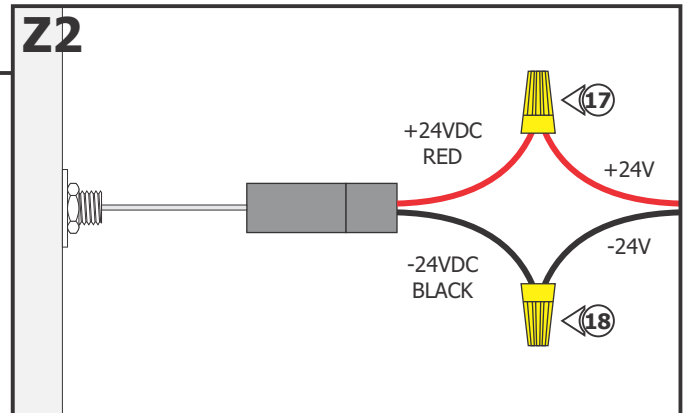

Z3

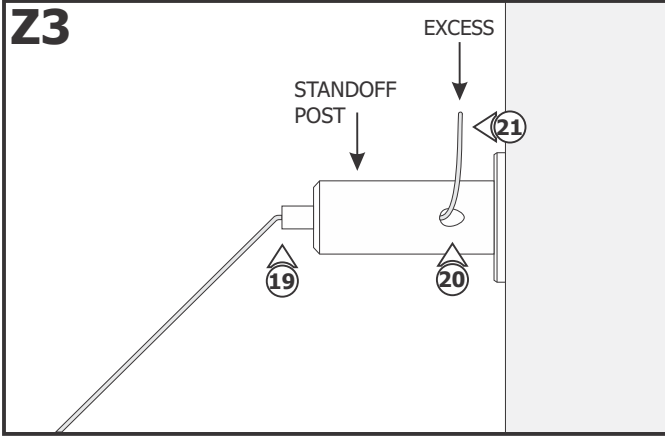

NOTE: Omit steps 19 through 21 if the stem length is 14" and less and no cantilever is used.

19: Feed the aircraft cable coming from the cantilever through the standoff post.

20: Adjust the cable by pushing the cord grip tab and pulling the cable out of the side of the standoff post. Release the cord grip tab to secure the cable in place.

21: If necessary, trim excess aircraft cable using sharp cutters.

Z4

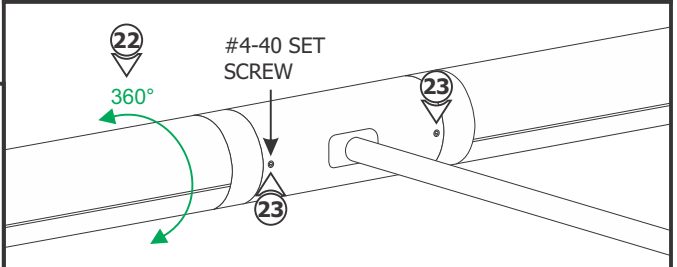
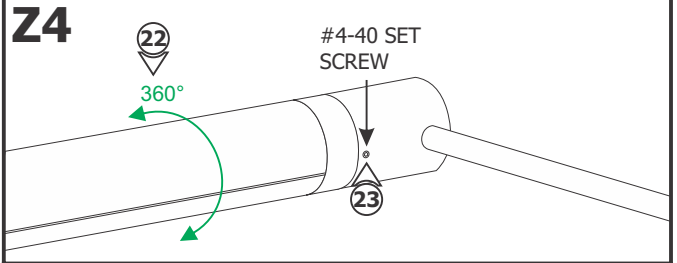

22: For final adjustments, loosen the #4-40 set screws using a 0.05" Allen wrench and rotate each channel to the desired angle.

23: Secure the channels by tightening the #4-40 set screws using a 0.05" Allen wrench.