



1718 W. Fullerton Chicago, IL 60614  
 Ph: 773.770.1195 • Fax: 773.935.5613  
 www.PureEdgeLighting.com • info@PureEdgeLighting.com  
 © 2016 PureEdge Lighting. All Rights Reserved.

## Installation Instructions for Pipeline Stem Mounted Straight Run Ceiling/Wall with 2" Canopy - Remote Power

P\_\_-2P-\_\_

### IMPORTANT INFORMATION

- This instruction shows a typical installation.
- This product is ceiling or wall mount.
- It is recommended more than one person assist in this installation.

**SAVE THESE INSTRUCTIONS!**

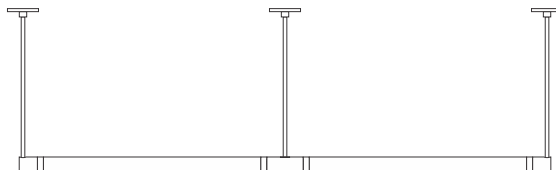

### Section One: Resize the Stem (Optional)

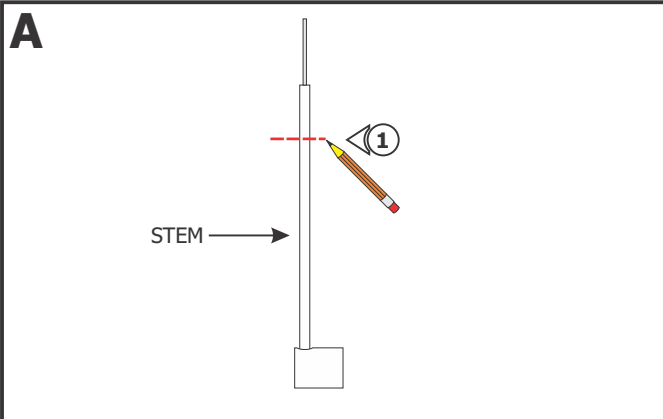

**NOTE:** Adjust the height of the stem. Omit this section if adjustments are not needed.

- 1:** From the end of the power feed stem, mark the stem to the amount that needs to be shorten. For example, to resize 24" stem to 17", mark 7" from the end of the power feed stem.

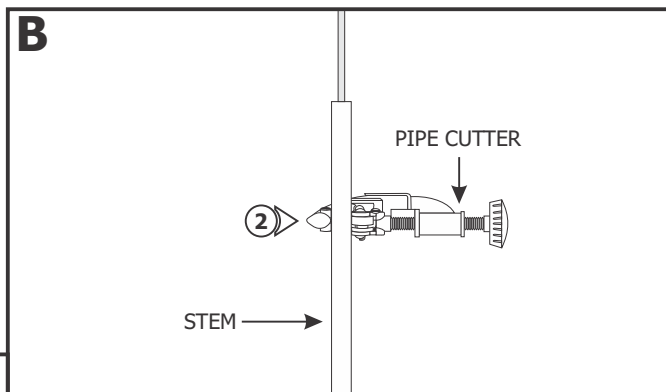

- 2:** Use a pipe cutter to cut out the excess rod.

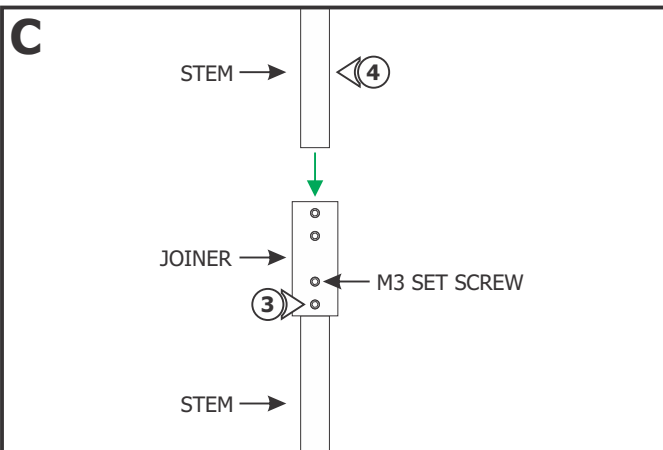

- 3:** To extend the rod, insert the stem half way into the joiner. Tighten the M3 set screws using a 1.5mm Allen wrench.

- 4:** Slide the other stem into the joiner and tighten the remaining set screws.

- 5:** Refer to steps 1 and 2 to cut the stem to desired length.

## Section Two: Assemble the fixture

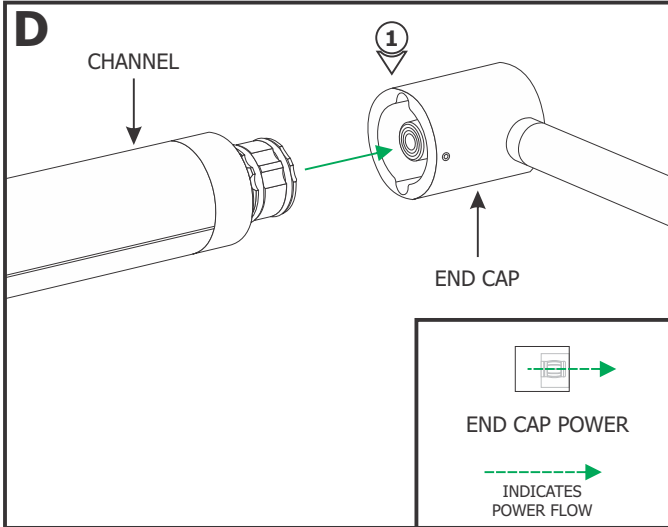

**NOTE:** Omit this section if the fixture is fully assembled.

**1:** Align the channel with the stem end cap and slide into place.

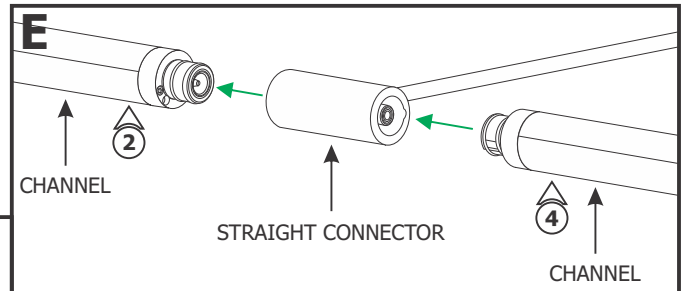

**NOTE:** Omit steps 2 through 4 if the fixture does not come with Straight Connector(s).

- 2:** The Straight Connector conducts power in one direction (left or right) or both directions.
- 3:** Depending on the design, ensure the conductive end of the Straight Connector is facing the correct direction.
- 4:** Snap the other end of the modular channel into the Straight Connector. Repeat these steps for all other Straight Connectors and remaining modular channels.

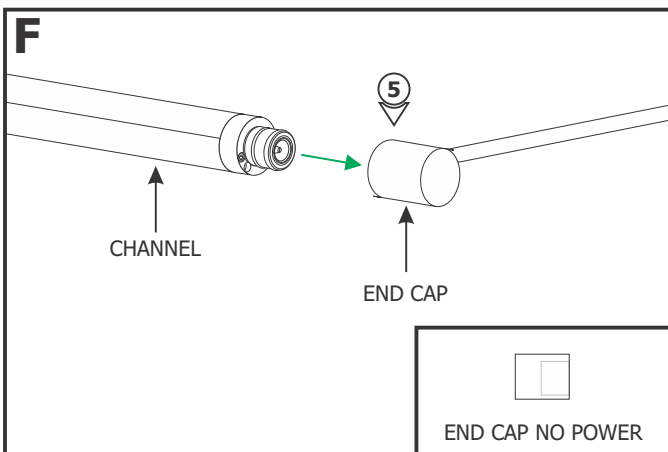

**5:** Snap the last channel to the last End Cap.

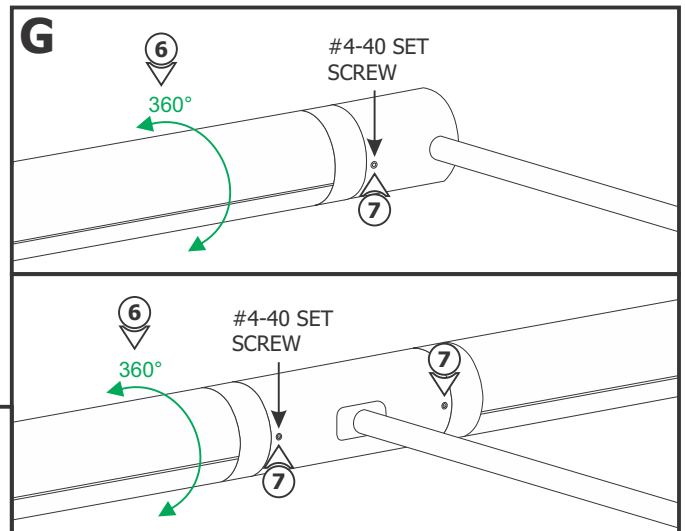

- 6:** Rotate each channel to the desired angle.
- 7:** Secure the channels by tightening the #4-40 set screws using a 0.05" Allen wrench.

## Section Three: Lay Out the Fixture and Install the Base

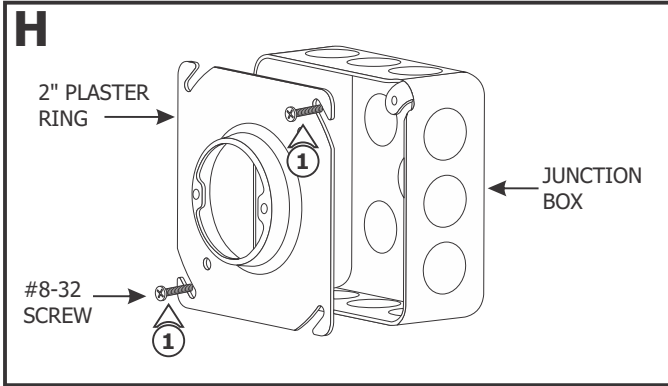

**NOTE:** To replace the existing plaster ring, some modification of drywall around the junction box is necessary.

**1:** Install 2" plaster ring to junction box and secure with two provided #8-32 screws. Install drywall and finish.

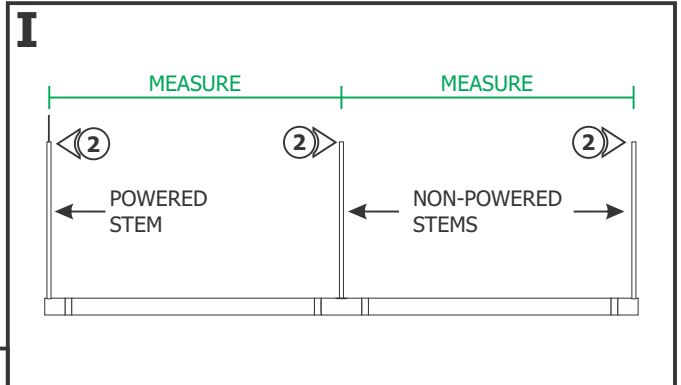

**2:** Measure the distance between the center of each stem.

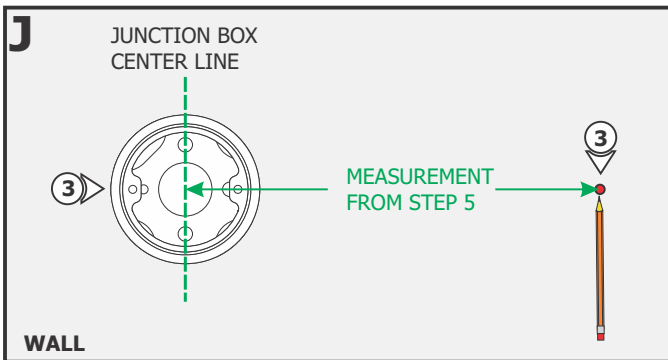

**3:** The stem containing the power cable should be aligned with the center of the junction box. Mark the location of the non-powered stem on the wall/ceiling from the center for the junction box. Ensure the marked point is leveled horizontally with the center of the junction box.

**4:** For the non-powered stems, center the base with the marked point and mark two additional locations through the holes.

**NOTE:** The base holes should be in a vertical position at 90° angle to the direction of the fixture.

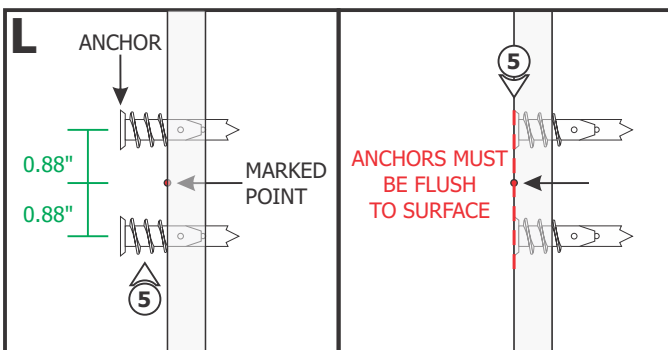
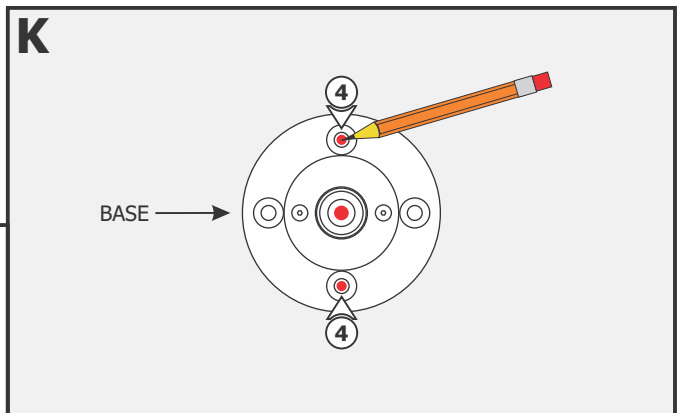

**NOTE:** Omit step 5 if mounting directly to a wood surface.

**5:** Tap the anchors to the new marked points with a hammer up to the threaded portion. Screw in the threaded portion of the anchors with a Phillips screw driver.

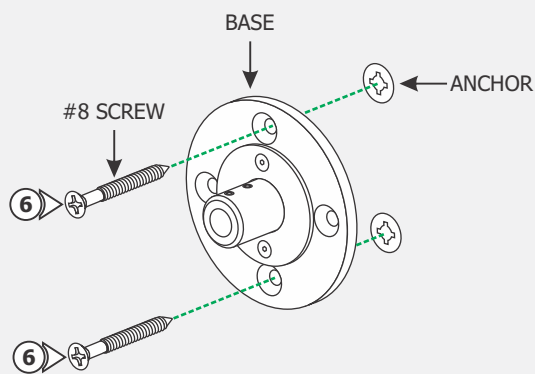
**M**

**6:** Secure the base to the anchors with two provided #8 screws.

## Section Four: Install Cantilevers (Wall Applications Only)

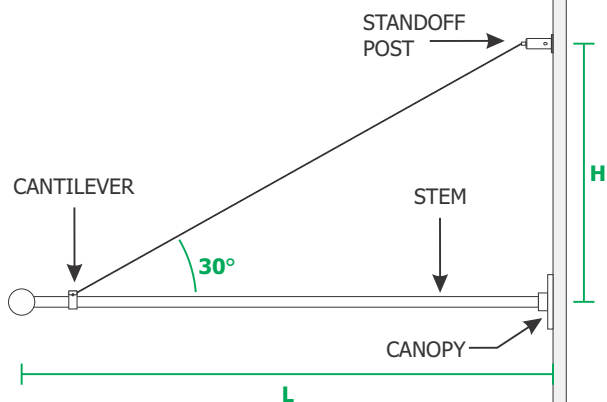
**N**

**NOTE:** Omit this section if the stem length is 14" and less and no cantilever is used (ceiling applications).

- 1: The standoff post should be above the canopy at a minimum of 30° angle between the stem and the cable to properly lock the cable position in place.
- 2: Use the tables below to determine the standoff post position relative to the canopy for various angles.

ANGLE	EQUATION FOR HEIGHT (H)
30°	$H = 0.6 \times L$
45°	$H = L$
60°	$H = 1.7 \times L$

**EXAMPLE**

LENGTH (L)	(H) FOR 30°	(H) FOR 45°	(H) FOR 60°
36"	21"	36"	62"
24"	14"	24"	42"

**3:** Mark out the cantilever location on the wall.

**NOTE:** Omit step 4 if mounting directly to a wood surface.

**4:** Tap the anchor to the marked point with a hammer up to the threaded portion. Screw in the threaded portion of the anchors with a Phillips screw driver.

**O**

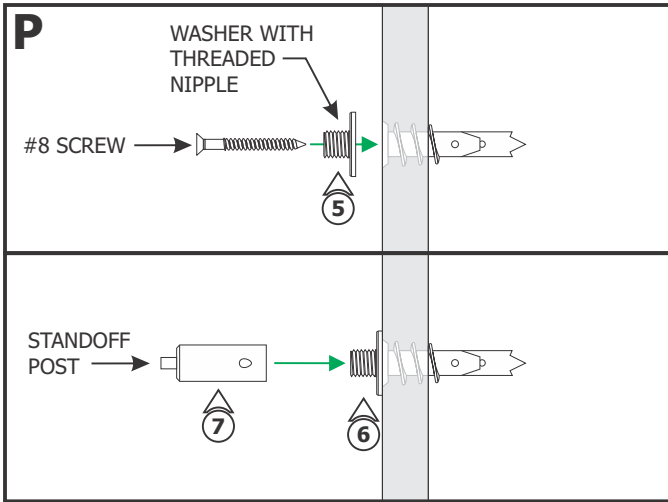

- 5:** Feed the #8 screw through the washer with threaded nipple into the anchor.
- 6:** Tighten the #8 screw completely into the anchor.
- 7:** Tighten the standoff post completely onto the threaded nipple.

## Section Five: Install the Fixture

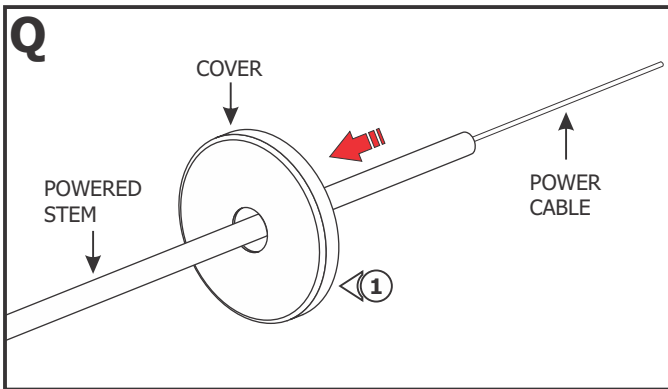

- 1:** Slide the canopy cover (provided) over the powered stem.

- 2:** Feed the power cable coming out of the stem through the base.
- 3:** Slide the base bushing completely onto the stem and secure it in place by tightening the #6-32 set screws with the provided 1/16" Allen wrench.

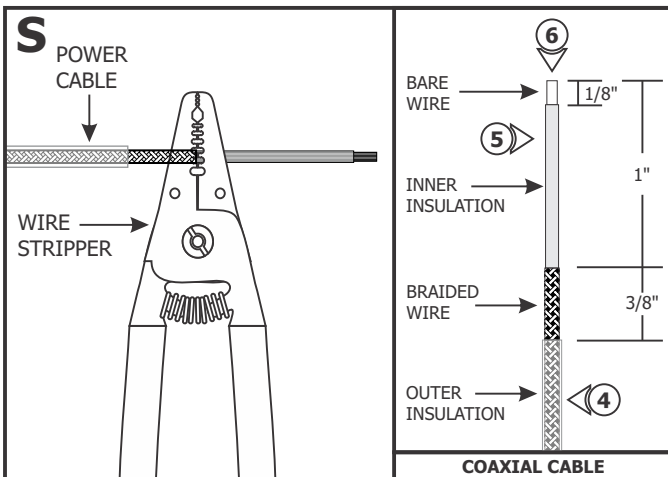
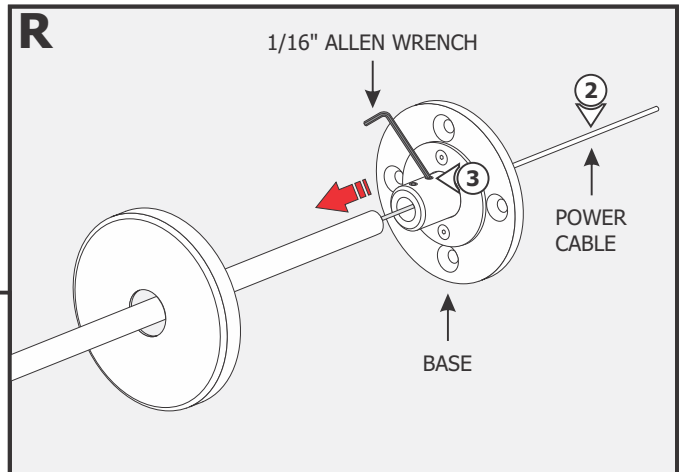

**NOTE:** Scan the QR Code to watch the video clip of the following steps or visit [https://www.PureEdgeLighting.com/video\\_feed/installation\\_cxc\\_connector](https://www.PureEdgeLighting.com/video_feed/installation_cxc_connector)

- 4:** Use the 18AWG hole of the wire stripper to remove 1-3/8" of the outer insulation to expose the braided wire.
- 5:** Use the 18AWG hole of the wire stripper to remove 1" of the braided wire making sure not to nick the inner wire insulation.
- 6:** Use the 20AWG hole of the wire stripper to remove 1/8" of the inner insulated wire.

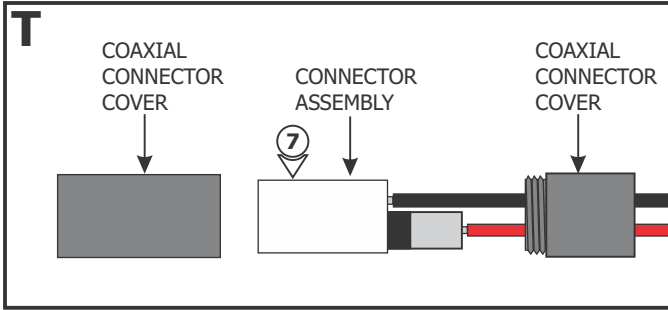

**7:** Unscrew the coaxial connector covers and remove from the connector assembly.

**8:** Using the provided 1.5mm Allen wrench, remove the M3 set screw from the coaxial connector assembly.

**9:** Using the provided 2mm Allen wrench to loosen (do not remove) the M4 set screw.

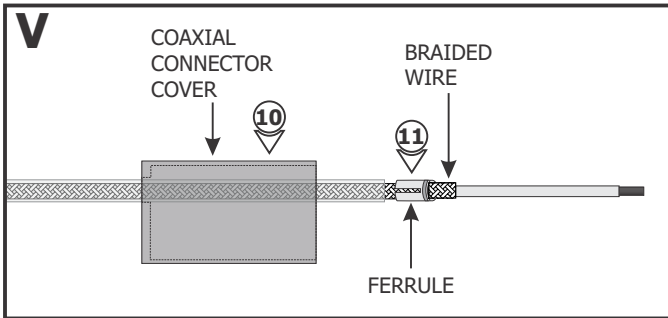
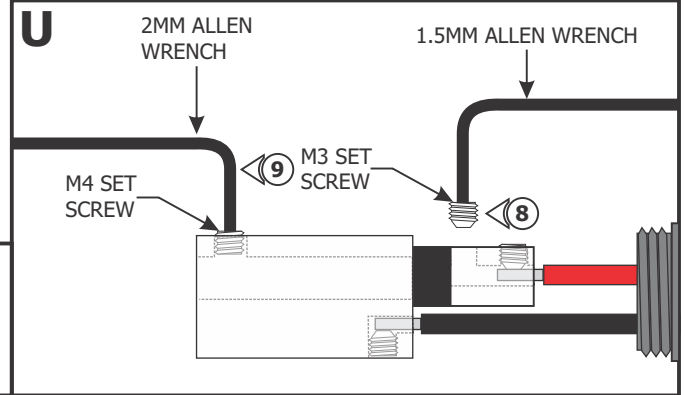

**10:** Slide the connector cover over the coaxial cable.

**11:** Place the ferrule over the 3/8" braided wire of the coaxial cable.

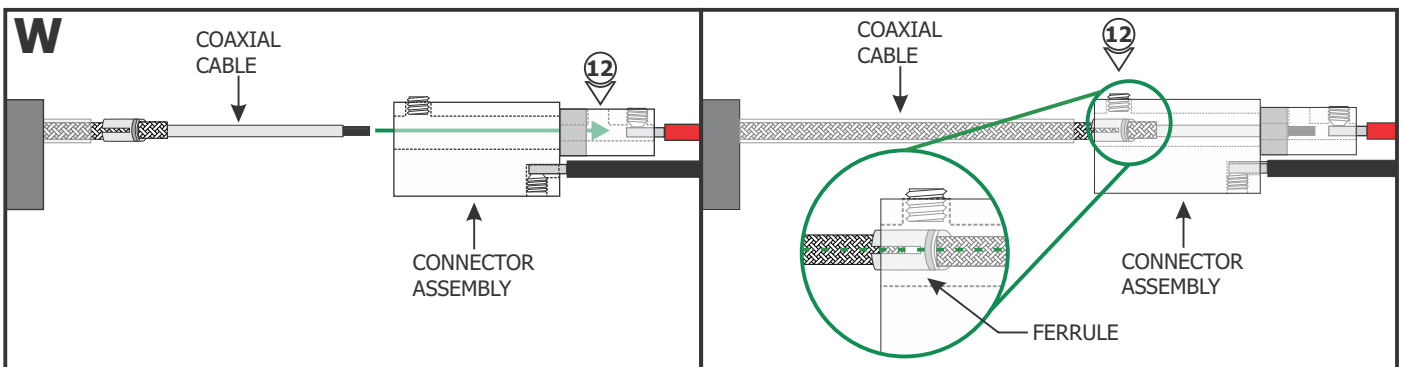

**12:** Insert the coaxial cable into the coaxial connector until the wires of the center conductor are visible through the M3 set screw hole.

**NOTE:** Ensure that the split in the ferrule is aligned 90° from the M4 set screw (see inset).

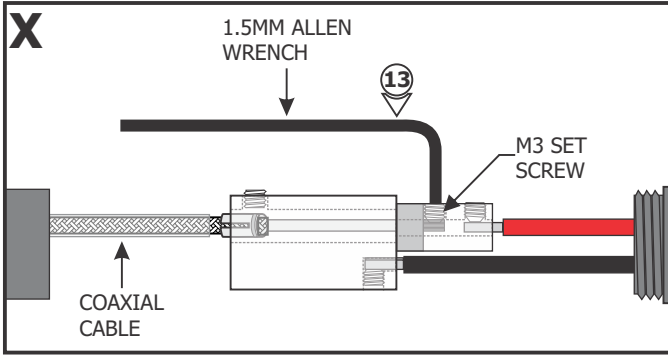

**13:** Use the provided 1.5mm Allen wrench to replace and securely tighten the M3 set screw.

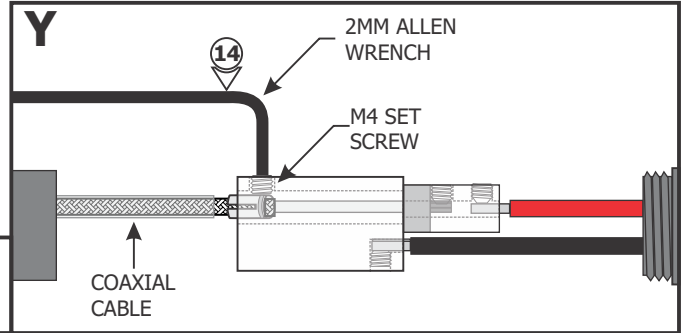

**14:** Use the provided 2mm Allen wrench to securely tighten the M4 set screw until it squeezes the wire ferrule tightly to the coaxial cable.

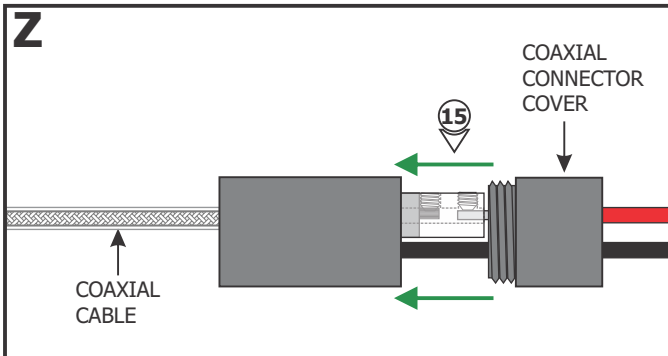

**15:** Replace the coaxial connector cover and tighten into place.

**NOTE:** The 24VDC power wires must be present in the junction box. Refer to the installation instructions provided with the power supply.

**NOTE:** It is recommended another person hold the fixture while the electrician connects the power to the fixture.

**16:** Connect the red fixture wire to the +24VDC power supply wire with a wire nut.

**17:** Connect the black fixture wire to the -24VDC power supply wire with a wire nut.

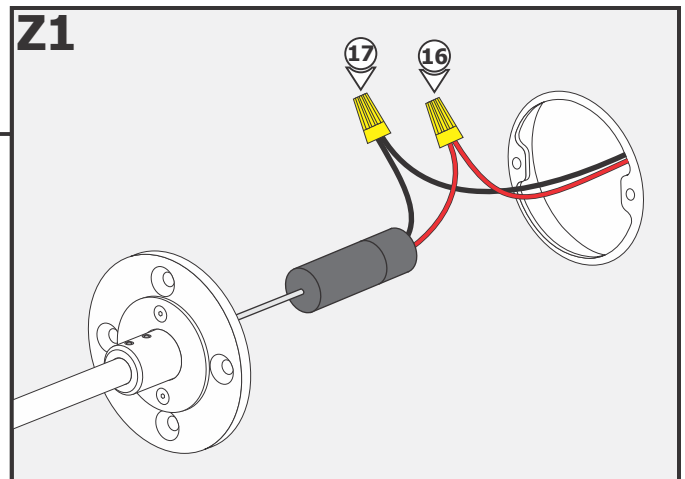

## Z2

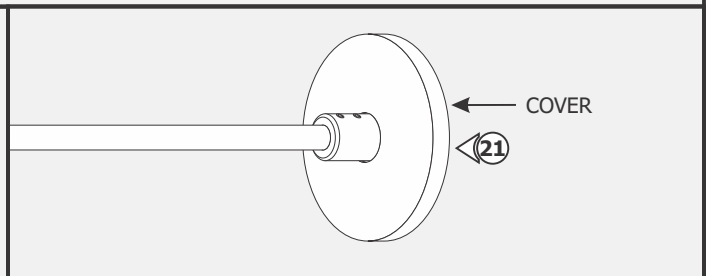
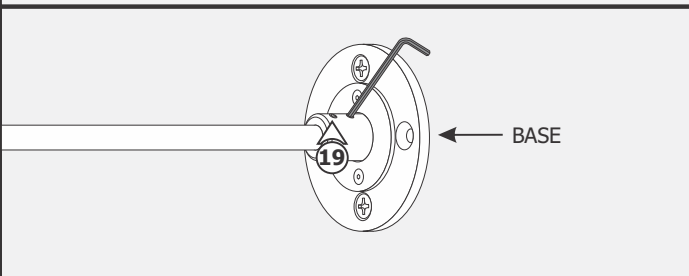
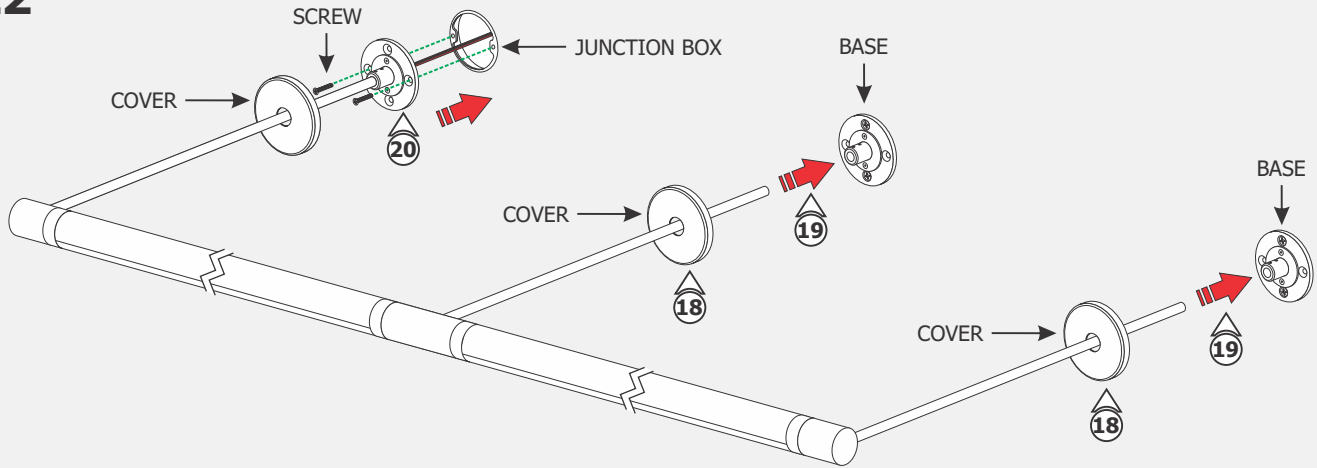

**18:** Slide the other canopy covers (provided) over the non-powered stems.

**19:** Place all wires and wire nut connections into the junction box and simultaneously align and insert the non-powered stems completely into the bases. Secure the stem by tightening the #6-32 set screws with the 1/16" Allen wrench.

**20:** Align the base of the powered stem with the junction box holes and secure it in place by tightening the two screws provided.

**21:** Slide the covers over the bases. The magnets on the back of the cover will keep the canopy in place.

## Z3

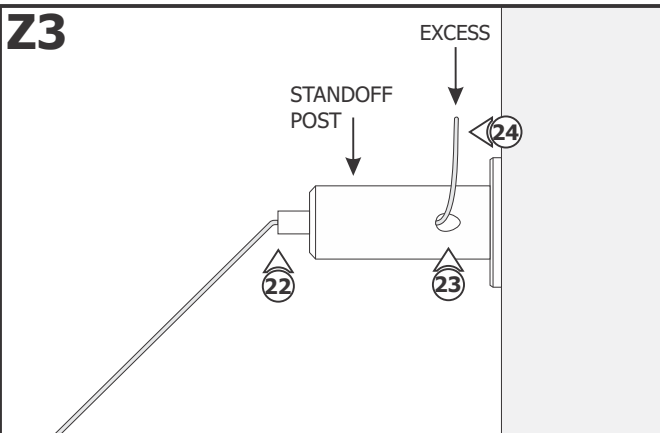

**NOTE:** Omit steps 22 through 23 if the stem length is 14" and less and no cantilever is used (ceiling applications).

**22:** Feed the aircraft cable coming from the cantilever through the standoff post.

**23:** Adjust the cable by pushing the cord grip tab and pulling the cable out of the side of the standoff post. Release the cord grip tab to secure the cable in place.

**24:** If necessary, trim excess aircraft cable using sharp cutters.



**Z4**

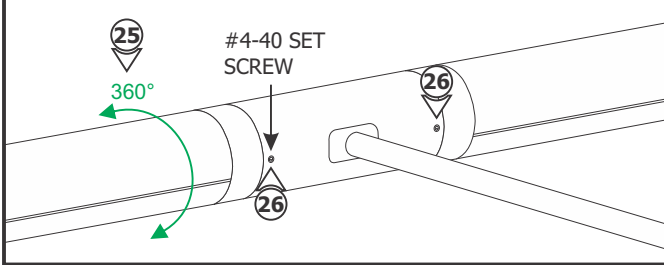
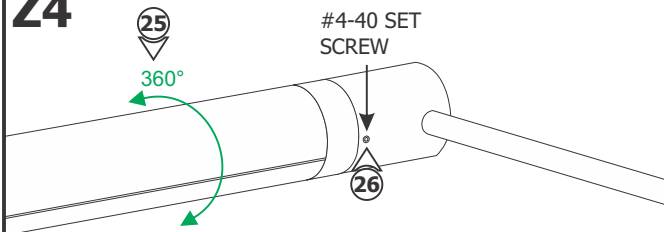

**25:** For final adjustments, loosen the #4-40 set screws using a 0.05" Allen wrench and rotate each channel to the desired angle.

**26:** Secure the channels by tightening the #4-40 set screws using a 0.05" Allen wrench.