



1718 W. Fullerton Chicago, IL 60614
 Ph: 773.770.1195 • Fax: 773.935.5613
 www.PureEdgeLighting.com • info@PureEdgeLighting.com
 © 2016 PureEdge Lighting. All Rights Reserved.

Installation Instructions for Nova Suspension Up and Down with Remote Power and 2" Square or Round Canopy

NSUD_-2_-__

IMPORTANT INFORMATION

- This instruction shows a typical installation.
- It is recommended more than one person to assist in this installation.

SAVE THESE INSTRUCTIONS!



Section One: Install the Standoff

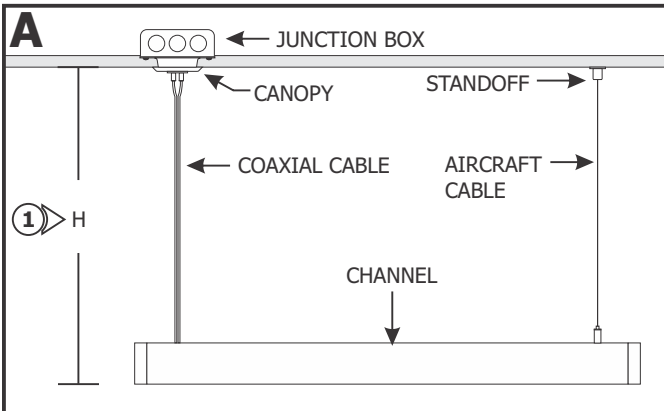

NOTE: Run the proper size wires between the 24VDC power supply to the electrical box. Refer to the instructions provided with the power supply for additional information.

NOTE: Omit Section Six if the channel is made out of a single piece.

- 1: Determine the fixture height (H) from the bottom of the channel to the top of the canopy.
- 2: Determine the fixture length (L). Measure the distance between the coaxial cable and the aircraft cable on the channel. Mark the standoff location on the ceiling from the center of the junction box.

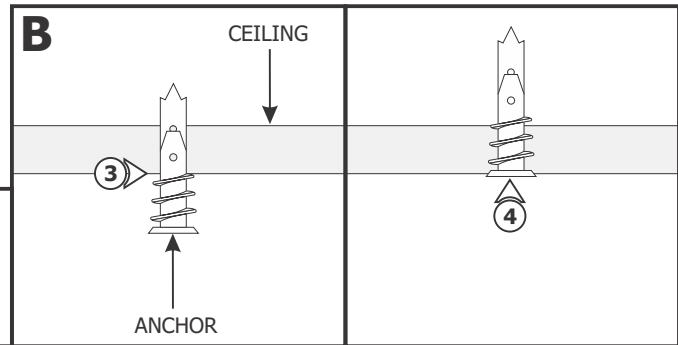
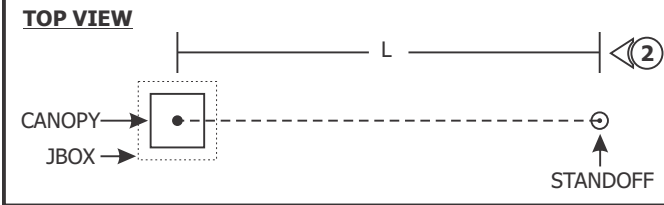

- 3: For each provided standoff, tap the anchor onto the marked location up to the threaded portion with a hammer.
- 4: Screw in the threaded portion of the anchors with a Phillips screwdriver.

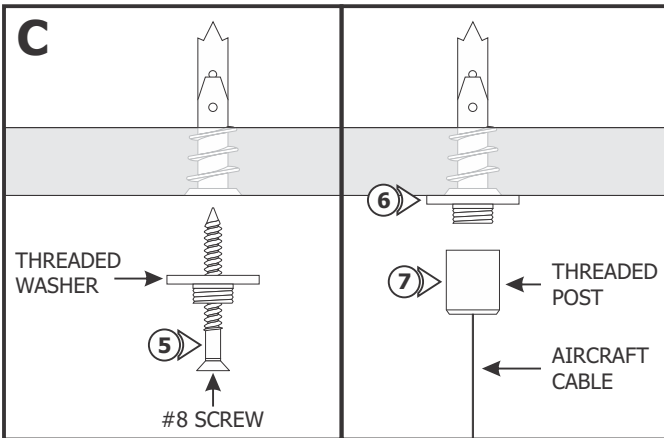

NOTE: Omit steps 5 through 7 if using support canopy. Refer to Section Two: Install the Support Canopy.

- 5: Feed the #8 screw through the threaded washer.
- 6: Tighten the #8 screw completely into the anchor.
- 7: Feed the aircraft cable through the threaded post. Tighten the threaded post completely onto the threaded washer.

Section Two: Install the Support Canopy

D

WASHER →

THREADED WASHER →

#8 SCREW

①

②

③

THREADED POST

- 1:** Feed the #8 screw through the washer with threaded nipple and 2" washer respectively into the anchor.
- 2:** Tighten the #8 screw completely into the anchor.
- 3:** Tighten the standoff post completely onto the threaded nipple.

E

④

CANOPY

STANDOFF POST

4: Place the canopy over the standoff post and magnetically attach the canopy to the washer.

Section Three: Adjust the Sliding Post

F

M3 SET SCREWS

①

②

SLIDING POST

- 1:** Loosen (**Do Not Remove**) the two M3 set screws on the sliding post with a 1.5mm Allen wrench.
- 2:** Adjust the position by moving the sliding post across the channel.

G

1.5MM ALLEN WRENCH

M3 SET SCREW

③

SLIDING POST

3: Tighten the two M3 set screws.

4: Repeat steps 1 through 3 for the remaining standoffs.

H

⑤

AIRCRAFT CABLE

TAB

⑥

⑦

EXCESS AIRCRAFT CABLE

- 5:** For each standoff, insert the aircraft cable through the top of the tab on the sliding post.
- 6:** Adjust the height of the fixture by pushing the tab and pulling the aircraft cable out of the side of the sliding post. Release the tab to secure the cable in place.
- 7:** If necessary, trim excess aircraft cable using sharp cutters.

Section Four: Install the 2" Plaster Ring

For New Construction

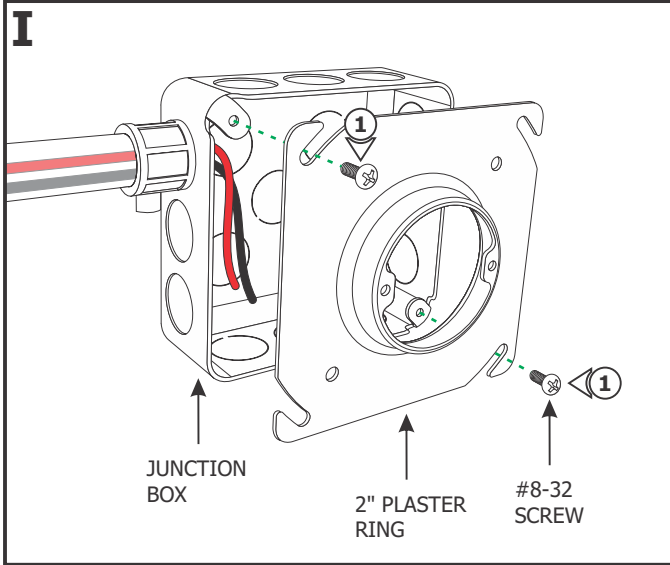

NOTE: Junction box must be mounted to allow clearance of 1/2" between the face of the junction box and the drywall surface.

NOTE: Ensure that the remote 24VDC power supply wires are present inside the junction box before continuing. Refer to the installation instructions provided with power supply.

1: Install the 2" plaster ring to the junction box using two #8-32 screws.

- 2:** Use a circular saw to cut out the drywall section where the plaster ring is located.
- 3:** Install the drywall. If necessary plaster, and finish the drywall.

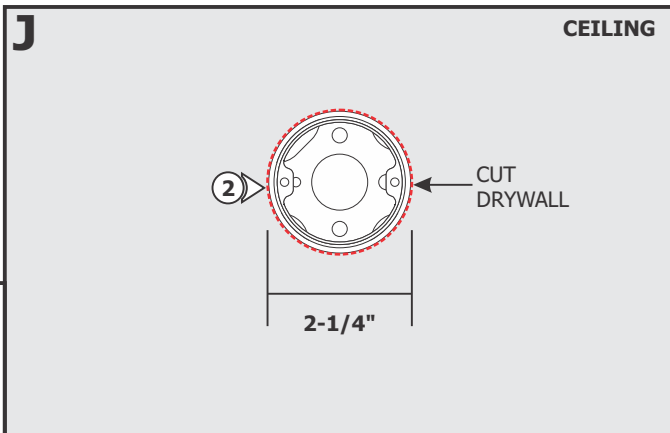

For Remodeling

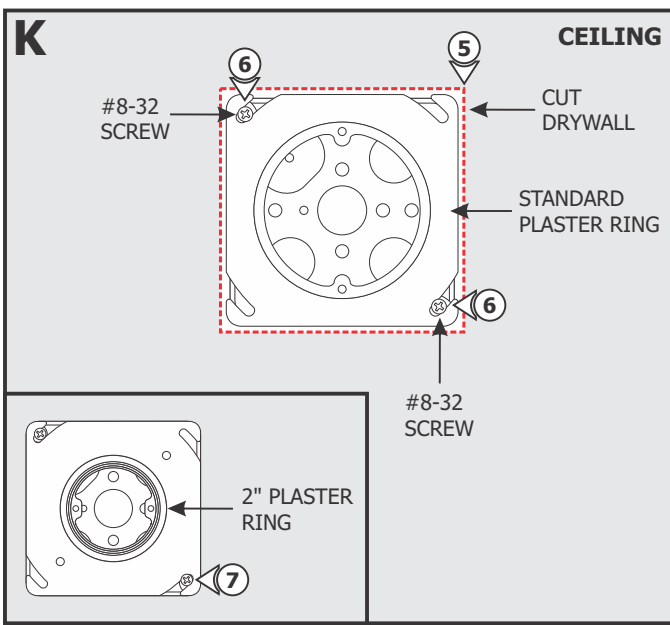

- 5:** Cut away the drywall where the junction box is located.
- 6:** Uninstall the existing plaster ring by removing the #8-32 screws.
- 7:** Install the 2" Plaster Ring to the junction box using two #8-32 screws.
- 8:** Plaster and finish around the junction box opening.

Section Five: Power the Fixture

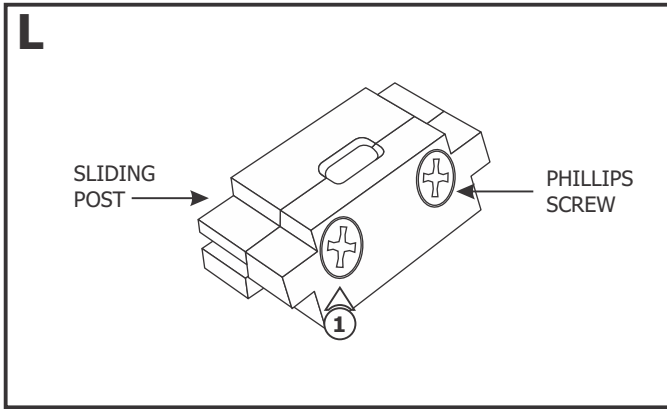

1: Remove the two Phillips screws from the sliding post.

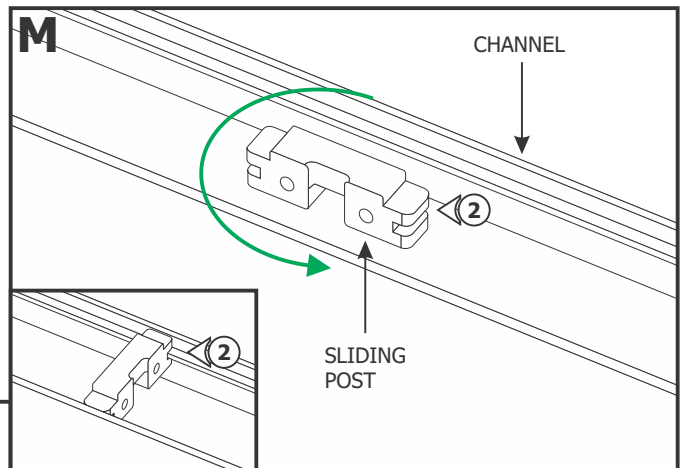

2: Place the back part of the sliding post inside the back of the channel and rotate it into place.

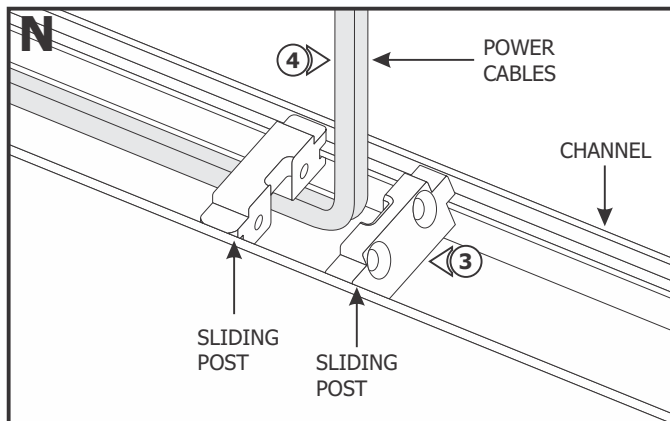

3: Place the other part of the sliding post onto the back of the channel.

4: Ensure that the power cables are in between the two parts of the sliding post.

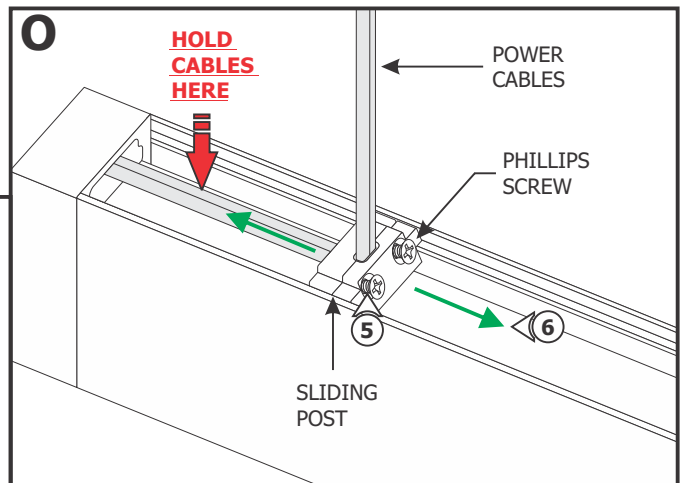

WARNING: To avoid damaging the coaxial cables electrical connections, make sure that the end of the coaxial cables coming out of the fixture is held with thumb before relocating sliding post.

5: Insert the two Phillips screws halfway into the sliding post to loosely join the two parts.

6: Adjust the position of the sliding post by moving it across the channel.

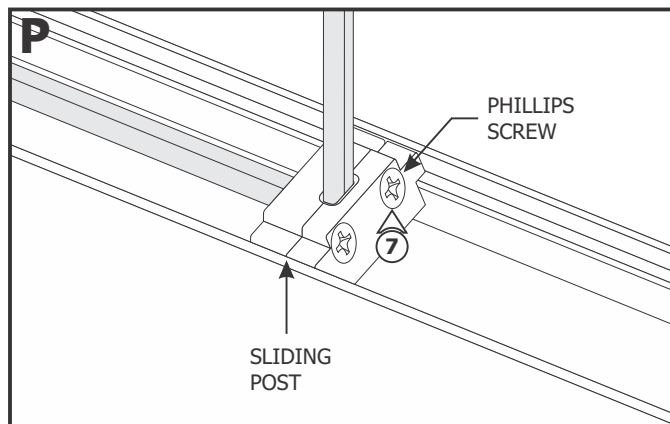

7: Tighten the two Phillips screws on the sliding post to secure it to the channel.

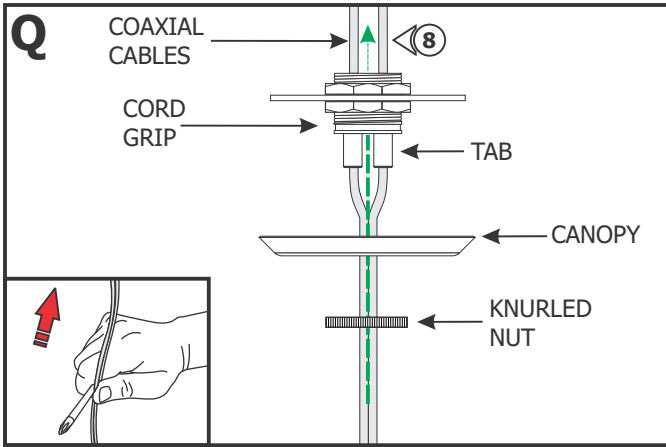

NOTE: If cable is curled or kinked, straighten by holding between the shaft of a screwdriver and thumb and pulling the cable through (see inset).

8: Split the end of the coaxial cable and feed the cables through the knurled nut, 2" canopy, and cord grip respectively.

 **NOTE:** Scan the QR Code to watch the video clip of the following steps or visit http://www.EdgeLighting.com/videos/cxc_connector/

- 9:** Use the 18AWG hole of the wire stripper to remove 1-3/8" of the outer insulation to expose the braided wire.
- 10:** Use the 18AWG hole of the wire stripper to remove 1" of the braided wire making sure not to nick the inner wire insulation.
- 11:** Use the 20AWG hole of the wire stripper to remove 1/8" of the inner insulated wire.

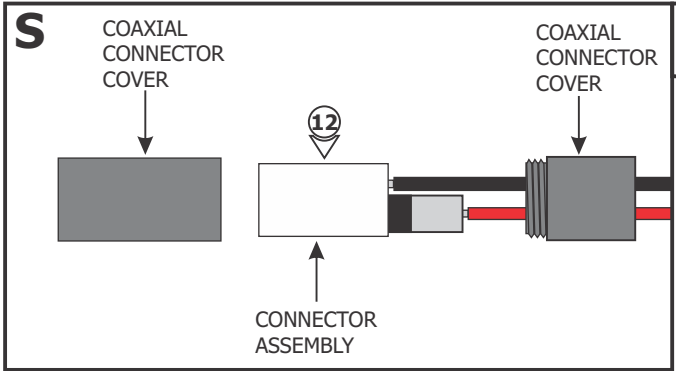
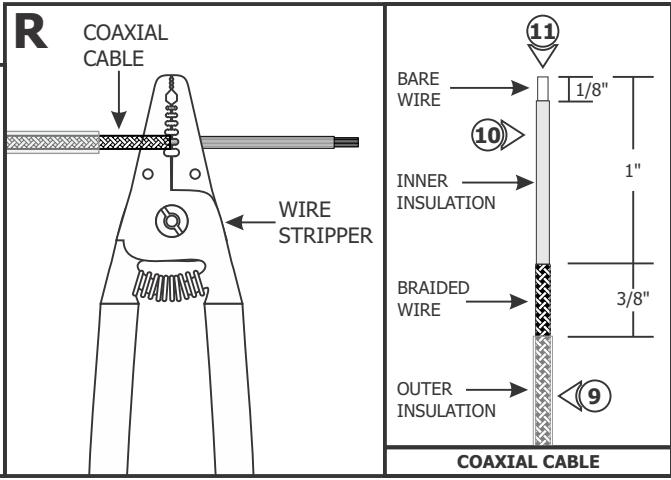

12: Unscrew the coaxial connector covers and remove from the connector assembly.

- 13:** Using the provided 1.5mm Allen wrench, remove the M3 set screw from the coaxial connector assembly.
- 14:** Using the provided 2mm Allen wrench to loosen (**Do Not Remove**) the M4 set screw.

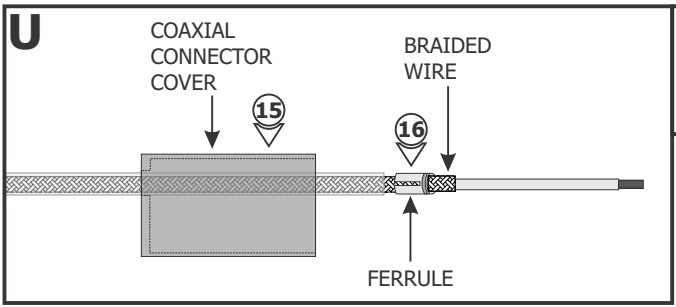
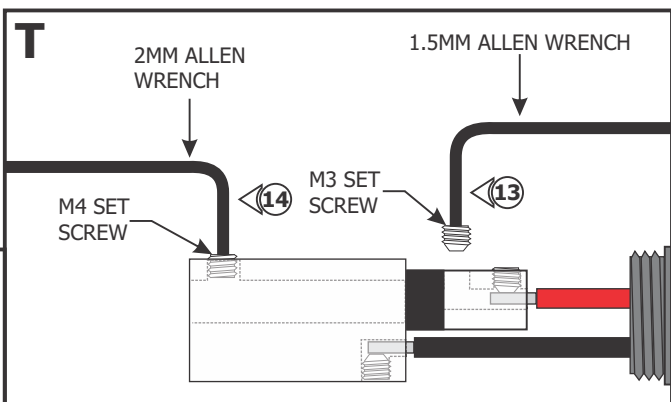

- 15:** Slide the connector cover over the coaxial cable.
- 16:** Place the ferrule over the 3/8" braided wire of the coaxial cable.

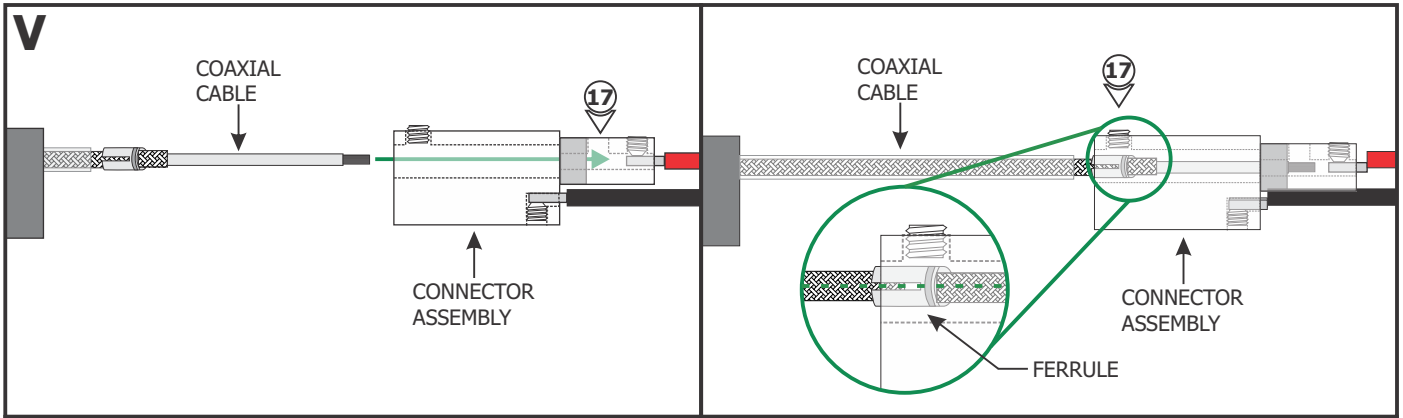

17: Insert the coaxial cable into the coaxial connector until the wires of the center conductor are visible through the M3 set screw hole.

NOTE: Ensure that the split in the ferrule is aligned 90° from the M4 set screw (see inset).

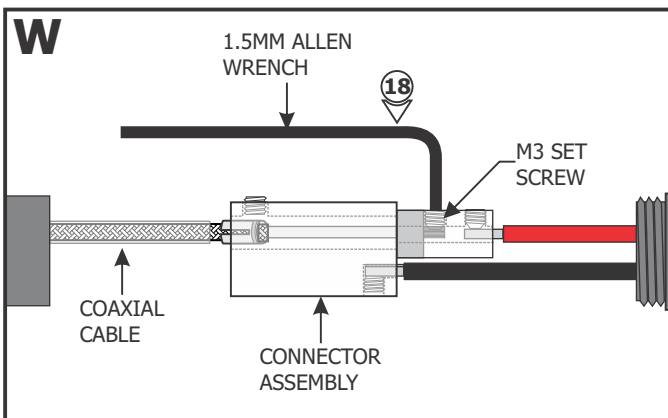

18: Use the provided 1.5mm Allen wrench to replace and securely tighten the M3 set screw.

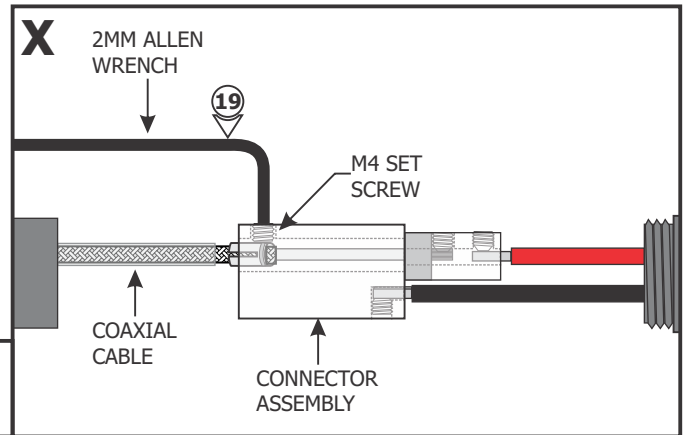

19: Use the provided 2mm Allen wrench to securely tighten the M4 set screw until it squeezes the wire ferrule tightly to the coaxial cable.

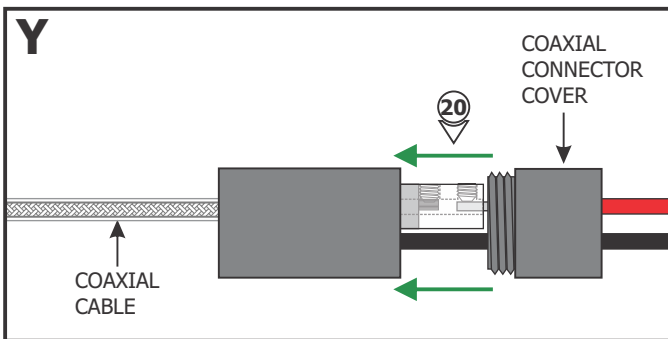

20: Replace the coaxial connector cover and tighten into place.

21: Repeat steps 9 through 20 for connecting the other coaxial cable.

22: Connect the red wire of one coaxial connector to a +24VDC power supply wire with a wire nut.

23: Connect the black wire of the same coaxial connector to a -24VDC wire of the same power supply with a wire nut.

24: Repeat steps 22 and 23 for connecting the other coaxial connector wires to the other power supply wires.

25: Place all connections inside the junction box.

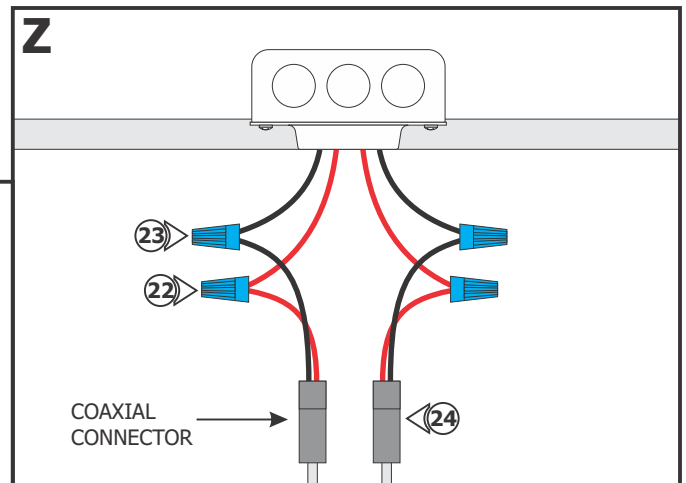

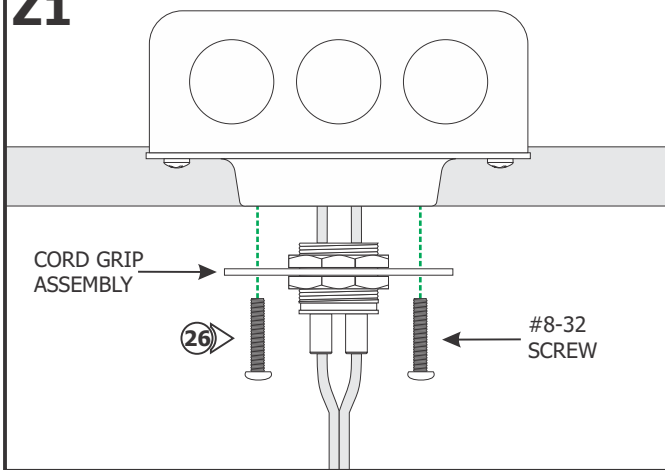
Z1

26: Mount the cord grip assembly to the 2" plaster ring using two #8-32 screws.

27: Place the canopy over the cord grip against the ceiling. Secure it in place by tightening the knurled nut to the cord grip. **Make sure the knurled cap is not cross threaded.**

28: If necessary, press the tabs on the cord grip to adjust the cable height.

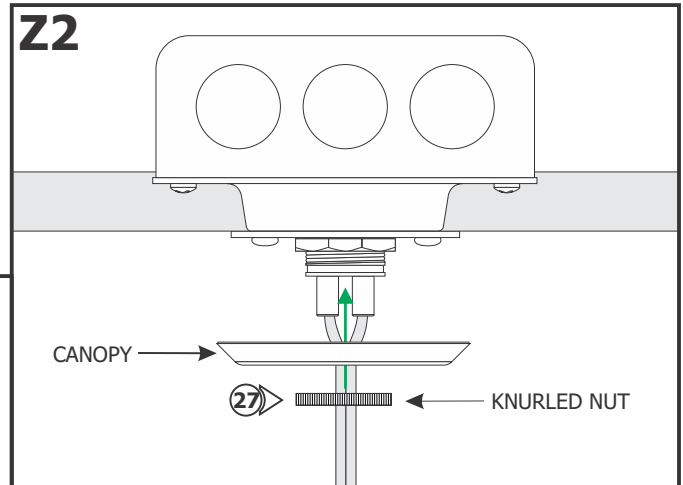
Z2

Section Six: Multiple Channel Sections

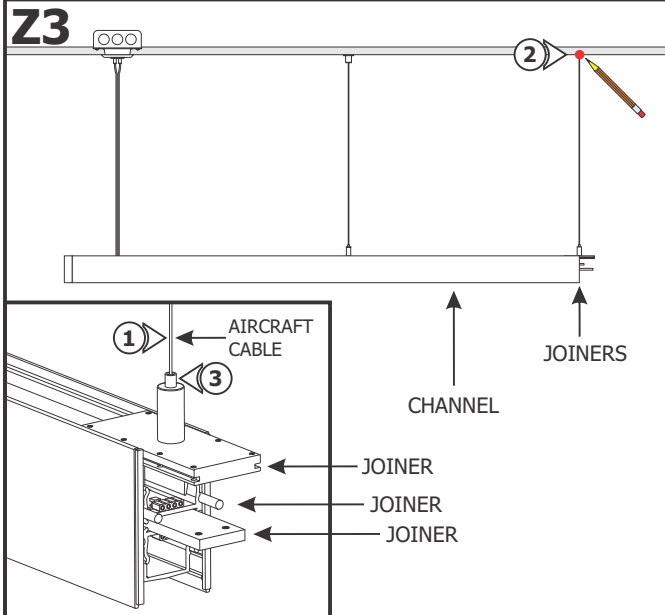
Z3

NOTE: If applicable, multiple channels must be installed one by one.

NOTE: Omit this section if the joiner did not come with the fixture depending on the overall fixture length.

NOTE: Omit steps 1 through 9 if the joiner did not come with aircraft cable depending on the overall fixture length.

- 1:** Insert the aircraft cable through the top of the tab on the joiner.
- 2:** Lift the other end of the aircraft cable against the ceiling to mark the location of the standoff.
- 3:** Push the tab on the joiner and remove the aircraft cable.

4: For each provided standoff, tap the anchor onto the marked location up to the threaded portion with a hammer.

5: Screw in the threaded portion of the anchors with a Phillips screwdriver.

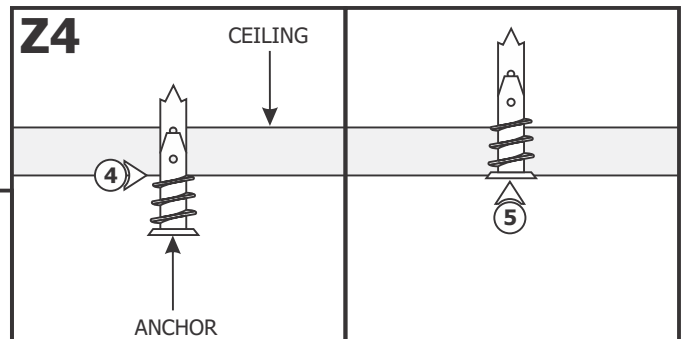
Z4

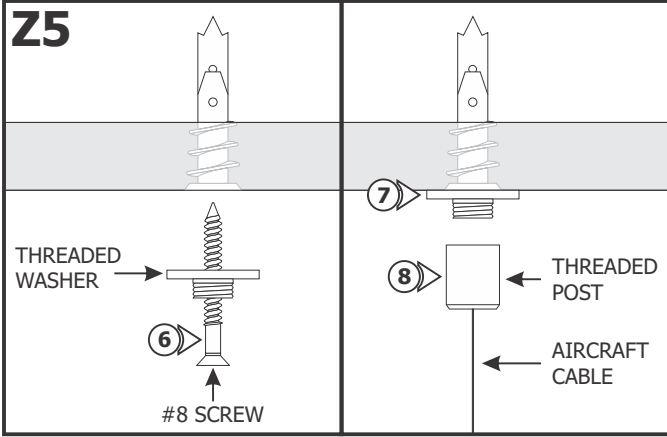

NOTE: Omit steps 6 through 8 if using support canopy. Refer to Section Two: Install the Support Canopy.

6: Feed the #8 screw through the threaded washer.

7: Tighten the #8 screw completely into the anchor.

8: Feed the aircraft cable through the threaded post. Tighten the threaded post completely onto the threaded washer.

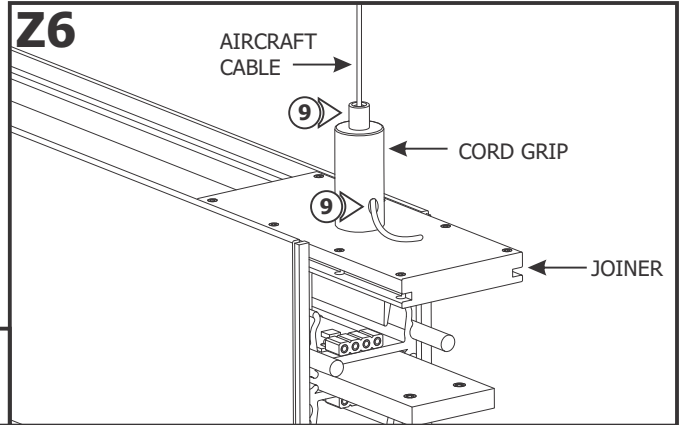

9: For each standoff, insert the aircraft cable through the cord grip on the top joiner and pull the aircraft cable out of the side.

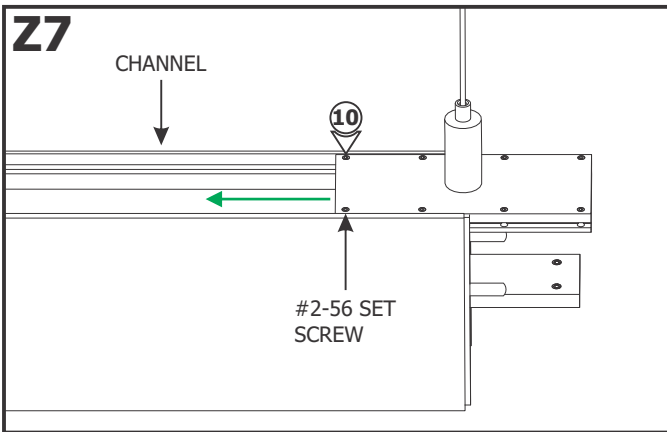

10: Loosen the four #2-56 set screws on the top joiner using a 0.035" Allen wrench and slide it inside the channel.

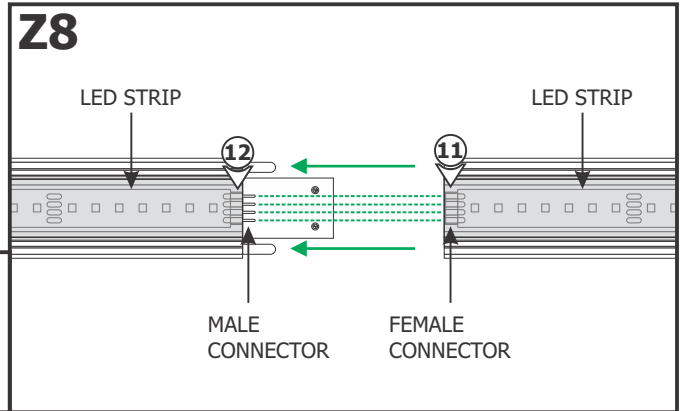

11: Align the female connector of the bottom LED strip on the channel with the bottom section of the other channel.

12: Slide the channel over the joiners. Ensure the connectors of the LED strips mate properly.

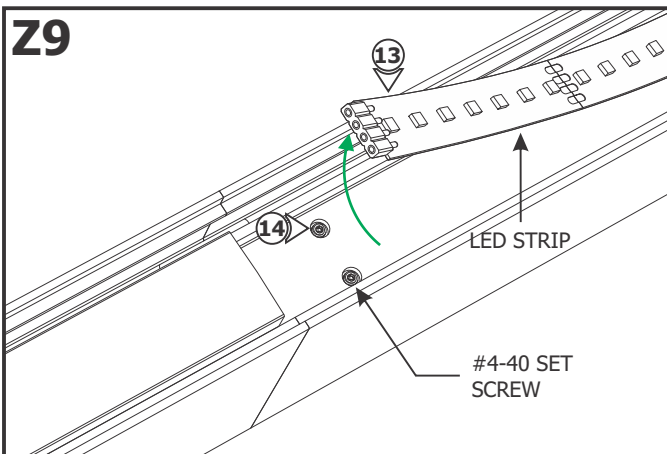

13: Lift a section of the top lens at the end of the channel. Slightly pull back the top LED strip to expose the set screw holes.

14: Secure the channel by tightening the two #4-40 set screws using a 0.05" Allen wrench.

Z10

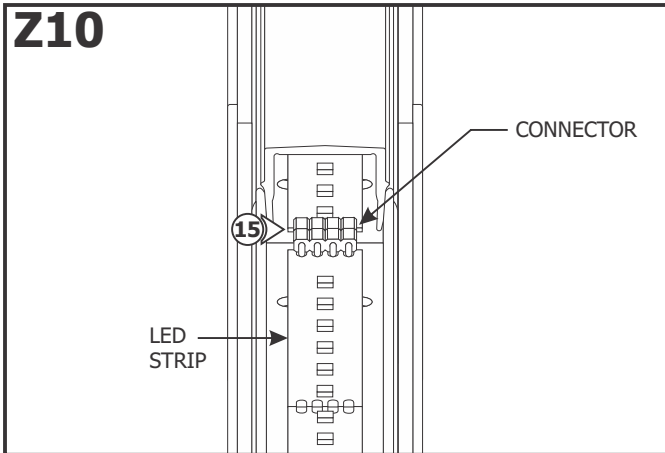

15: Connect the male & female connectors of the top LED strips. Firmly press down the adhesive portion of the LED strip onto the channel, making sure there are no air bubbles that can cause surface irregularities.

16: Press the lens back onto the channel.

17: Slide the top joiner back to the proper location and tighten the eight #2-56 set screws to lock it in place.

18: Adjust the height of the fixture by pushing the tab and pulling the aircraft cable out of the side of the joiner. Release the tab to secure the cable in place.

19: If necessary, trim excess aircraft cable using sharp cutters.

20: Refer to Sections One or Two to install remaining standoffs and continue to connect additional channels one at a time until the fixture is complete.

Z11

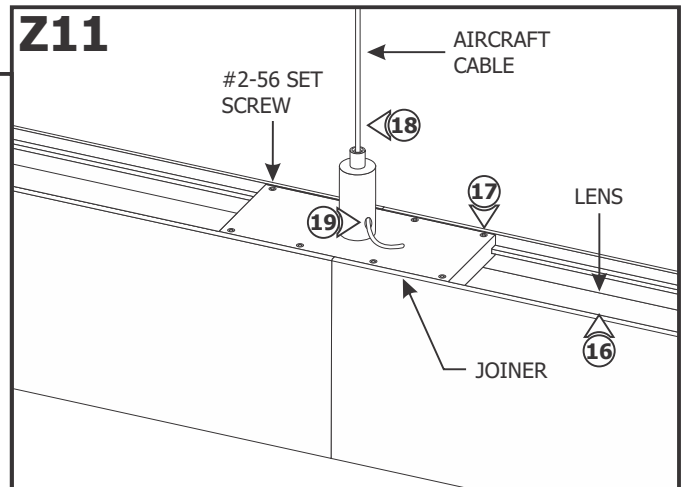

General ELV Wiring Diagram

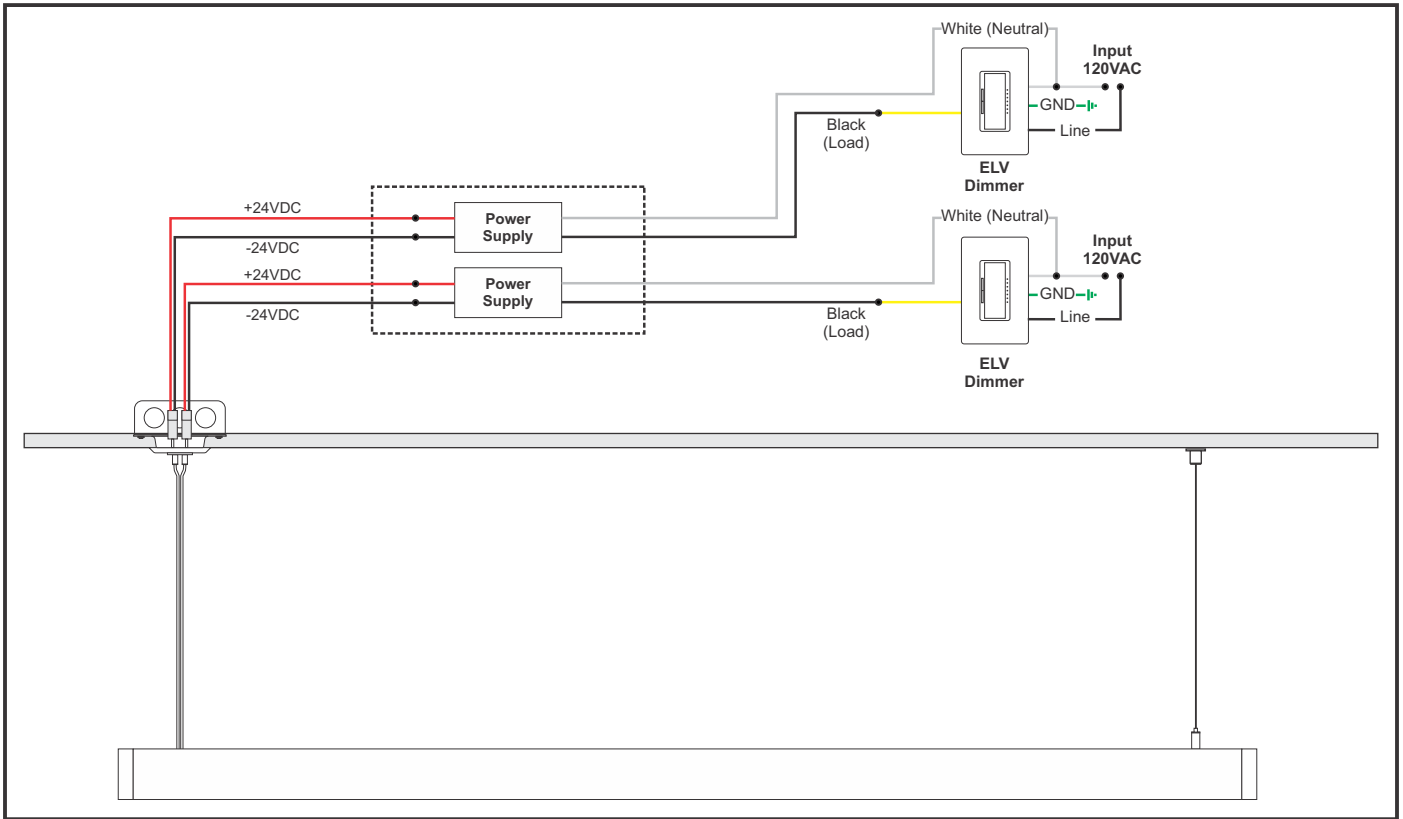

General 0-10V Wiring Diagram

