



1718 W. Fullerton Chicago, IL 60614  
 Ph: 773.770.1195 • Fax: 773.935.5613  
 www.PureEdgeLighting.com • info@PureEdgeLighting.com  
 © 2016 PureEdge Lighting. All Rights Reserved.

## Installation Instructions for Nova Large MIYO Hexagon LED Suspension Downlight with Power - End Feed Lit Corners

NSLDP-HX-\_-E-\_-

### IMPORTANT INFORMATION

- This product is suitable for indoor locations.
- This instruction shows a typical installation.
- The luminaire either comes with a 4" flush canopy for the fixtures up to 50W or with an 8" round surface mount canopy for greater than 50W.

**SAVE THESE INSTRUCTIONS!**

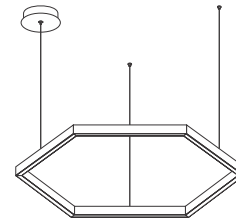

### Section One: 4" Flush Canopy

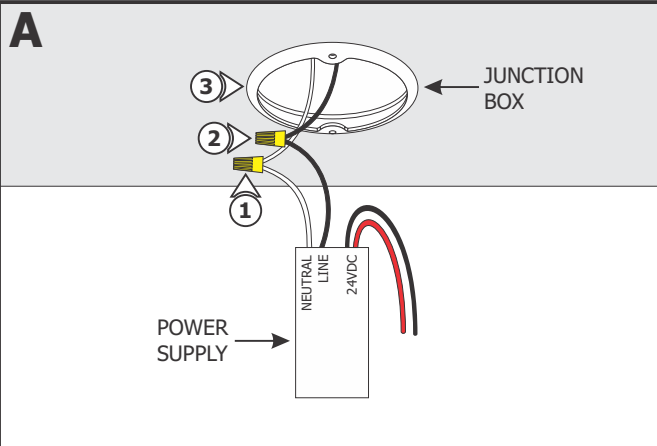

**NOTE:** Before beginning any electrical work, ensure that power to the junction box is turned off.

**NOTE:** Omit this section if using the 8" Surface Mount Canopy. Refer to Section Two.

- 1: Connect the white wire of the power supply to the 120VAC neutral wire with a wire nut.
- 2: Connect the black wire of the power supply to the 120VAC line wire with a wire nut.
- 3: Place the power supply and wires inside the junction box.

4: Feed the low voltage wires from the power supply through the center hole of the mounting ring.

5: Mount the ring to the junction box holes with two #8-32 screws.

6: Make sure that the mounting ring is grounded in accordance with local electrical codes.

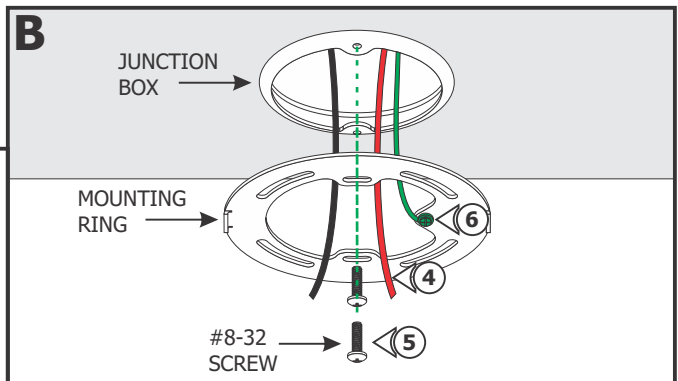

### Section Two: 8" Surface Mount Canopy

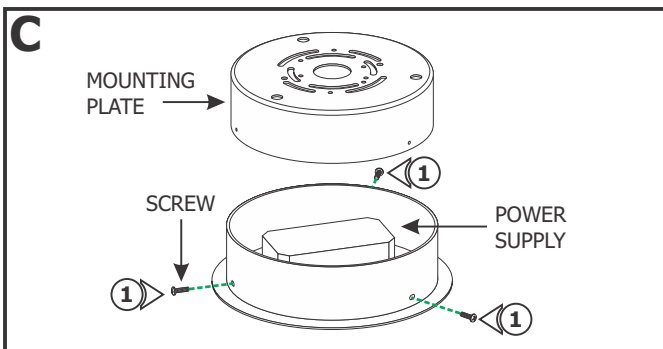

- 1: Remove the three Phillips screws from the canopy to remove the mounting plate.

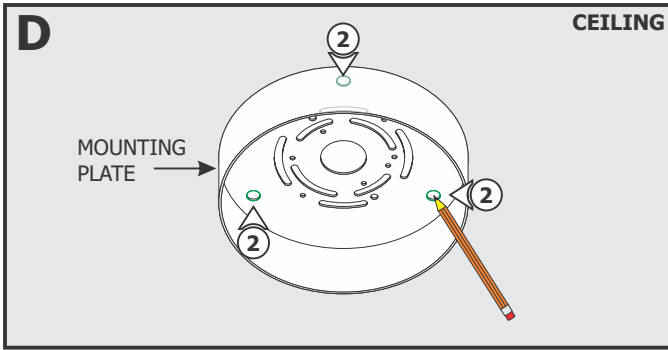

**2:** Align the mounting plate holes with the junction box holes and mark the points through the mounting plate holes onto the ceiling. These points are used for the anchors.

**NOTE:** Omit step 3 if mounting directly to a wood surface.

**3:** Tap the anchors onto the marked points up to the threaded portion with a hammer. Then screw in the threaded portion with a Phillips screw driver.

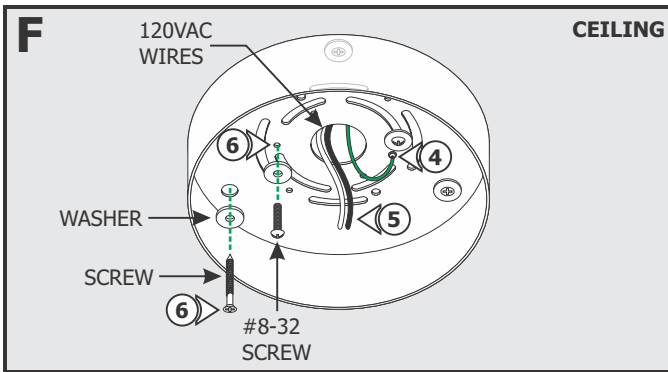
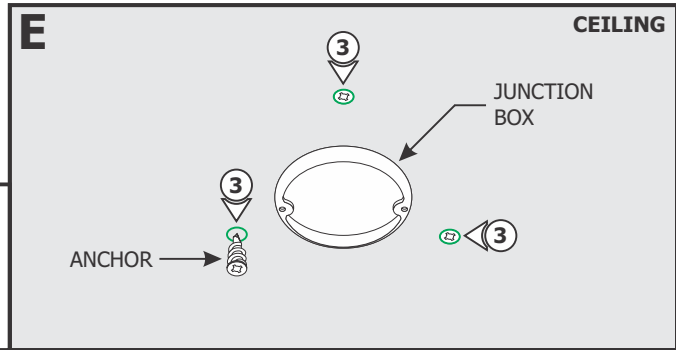

**4:** Make sure the mounting plate is grounded in accordance with local electrical codes.

**5:** Feed the 120VAC power wires through the center hole of the mounting plate.

**6:** Secure the mounting plate to the junction box and anchors using the provided screws and washers.

### Section Three: Install the Standoff

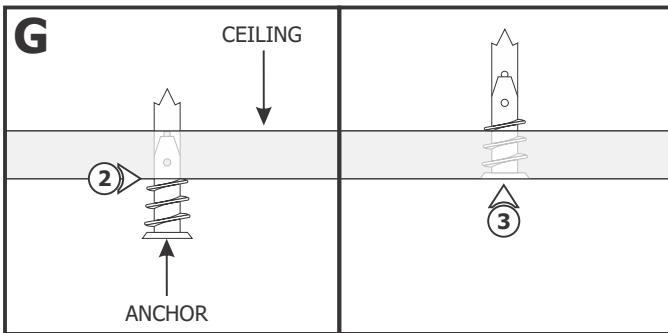

**1:** Insert aircraft cables through the suspension post on the top of the sliding posts. Lift the end of each aircraft cable against the ceiling to mark the locations of the standoffs.

**NOTE:** Omit steps 2 and 3 if mounting directing to a wood surface.

**2:** For each provided standoff, tap the anchor onto the marked location up to the threaded portion with a hammer.

**3:** Screw in the threaded portion of the anchors with a Phillips screwdriver.

**4:** Feed the #8 screw through the threaded washer.

**5:** Tighten the #8 screw completely into the anchor.

**6:** Feed the aircraft cable through the threaded post. Tighten the threaded post completely onto the threaded washer.

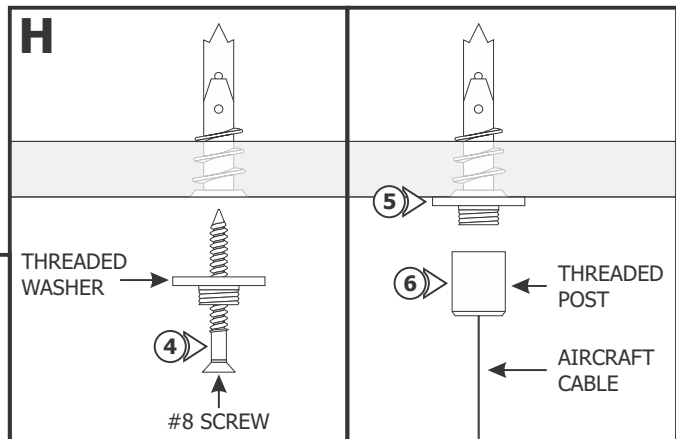

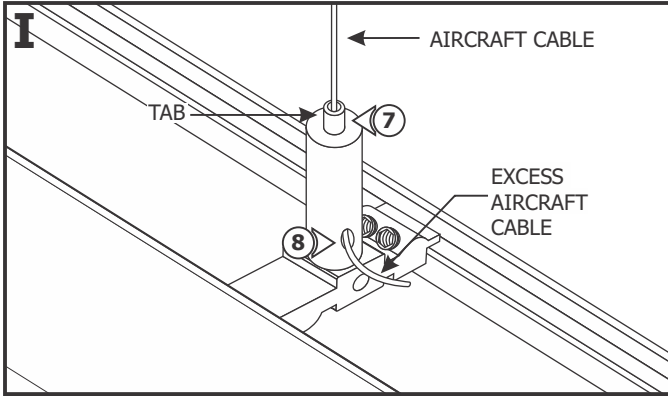

- 7:** Adjust the fixture height by pushing the tab on the cord grip and pulling the aircraft cable out of the side of the suspension post. Release the cord grip tab to secure the cable in place.
- 8:** If necessary, trim excess aircraft cable using sharp cutters.

## Section Four: Install the Fixture

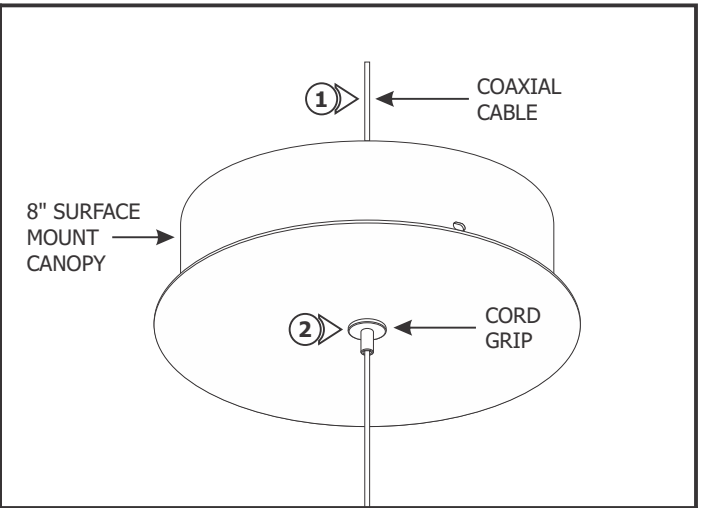
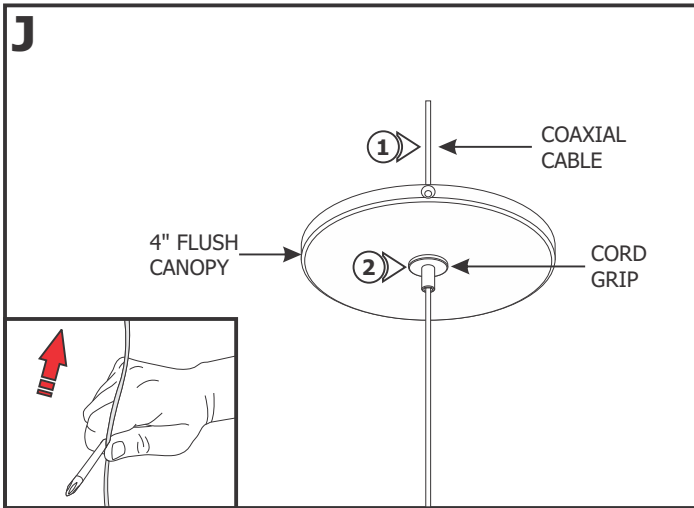

- 1:** Push the coaxial cable through the cord grip on the canopy.
- 2:** Adjust the fixture height by pushing the cord grip to slide the fixture up and down. Release the cord grip to lock the coaxial cable in place.

**NOTE:** If cable is curled or kinked, straighten by holding between the shaft of a screwdriver and thumb and pulling the cable through (see inset).

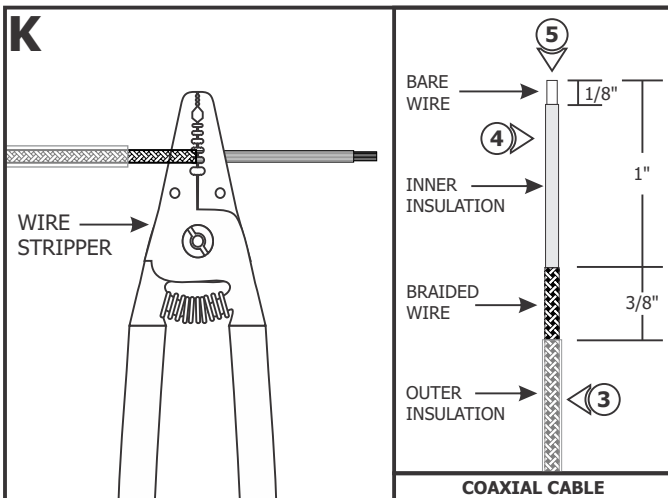

**NOTE:** Scan the QR Code to watch the video clip of the following steps or visit [https://www.PureEdgeLighting.com/video\\_feed/installation\\_cxc\\_connector](https://www.PureEdgeLighting.com/video_feed/installation_cxc_connector)

- 3:** Use the 18AWG hole of the wire stripper to remove 1-3/8" of the outer insulation to expose the braided wire.
- 4:** Use the 18AWG hole of the wire stripper to remove 1" of the braided wire making sure not to nick the inner wire insulation.
- 5:** Use the 20AWG hole of the wire stripper to remove 1/8" of the inner insulated wire.

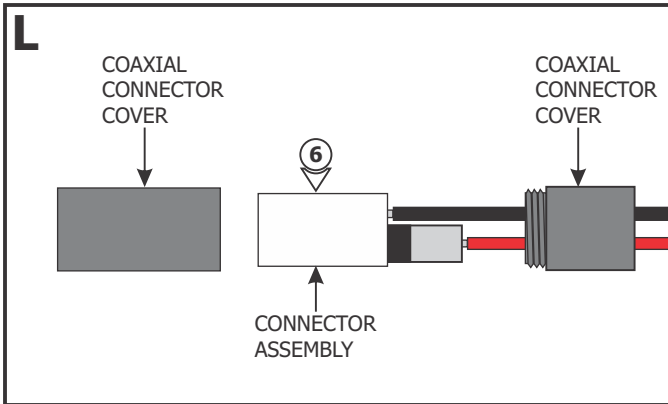

**6:** Unscrew the coaxial connector covers and remove from the connector assembly.

**7:** Using the provided 1.5mm Allen wrench, remove the M3 set screw from the coaxial connector assembly.

**8:** Using the provided 2mm Allen wrench to loosen (do not remove) the M4 set screw.

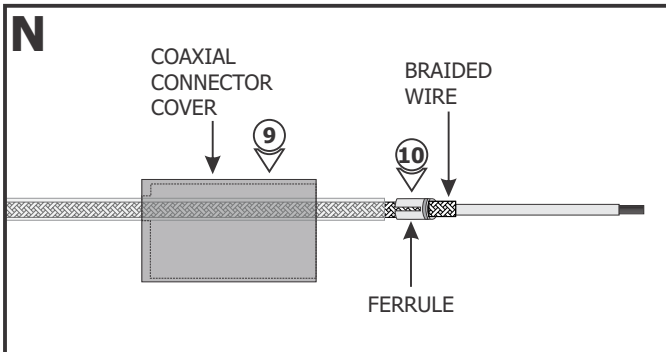
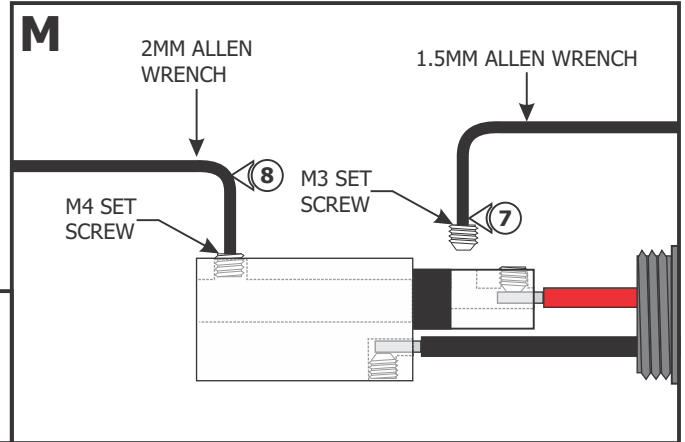

**9:** Slide the connector cover over the coaxial cable.

**10:** Place the ferrule over the 3/8" braided wire of the coaxial cable.

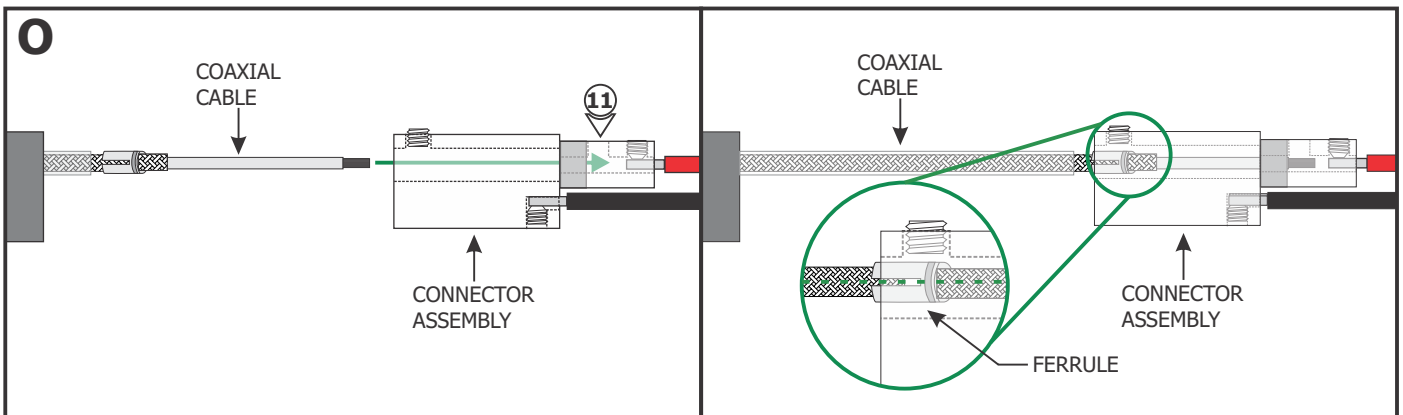

**11:** Insert the coaxial cable into the coaxial connector until the wires of the center conductor are visible through the M3 set screw hole.

**NOTE:** Ensure that the split in the ferrule is aligned 90° from the M4 set screw (see inset).

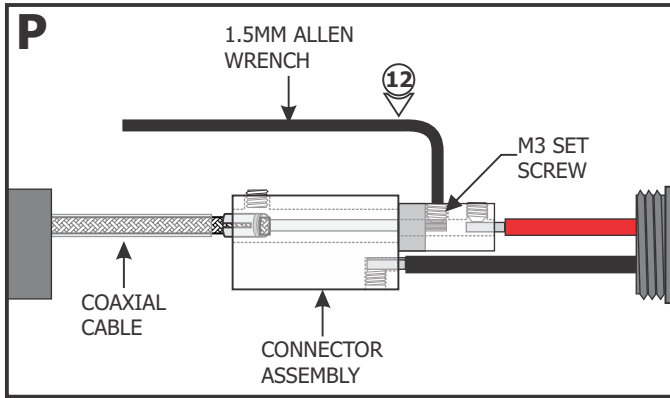

**12:** Use the provided 1.5mm Allen wrench to replace and securely tighten the M3 set screw.

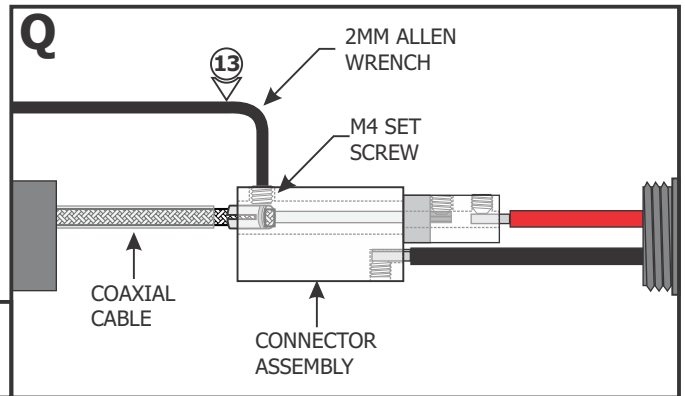

**13:** Use the provided 2mm Allen wrench to securely tighten the M4 set screw until it squeezes the wire ferrule tightly to the coaxial cable.

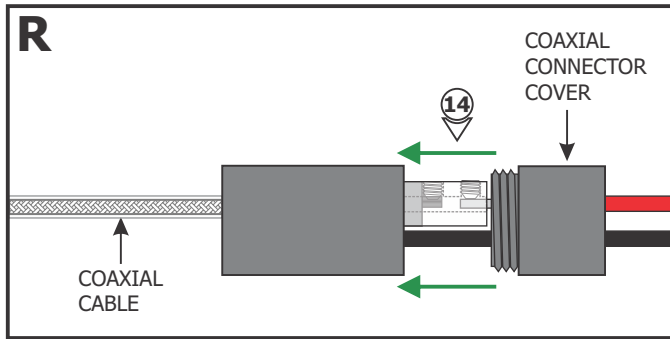

**14:** Replace the coaxial connector cover and tighten into place.

**15:** Connect the red wire of the coaxial connector to the +24VDC power supply wire using a wire nut.

**16:** Connect the black wire of the coaxial connector to the -24VDC power supply wire using a wire nut.

**For 8" Surface Mount Canopy:**

**17:** Connect the white wire of the power supply to the 120VAC neutral wire using a wire nut.

**18:** Connect the black wire of the power supply to the 120VAC line wire using a wire nut.

**CAUTION:** Test the fixture before continuing.

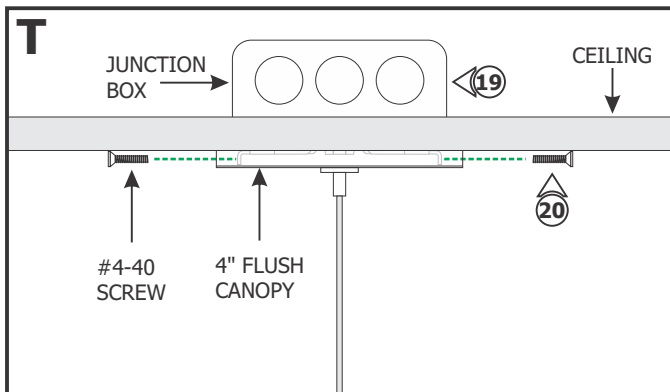
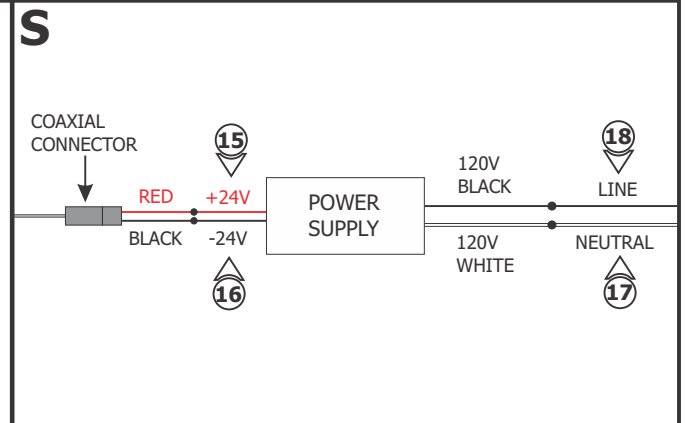

**For 4" Flush Canopy:**

**19:** Place all wires and wire nut connections inside the junction box.

**20:** Align the 4" canopy with the crossbar and secure it with the two #4-40 screws using a 1/16" Allen wrench.

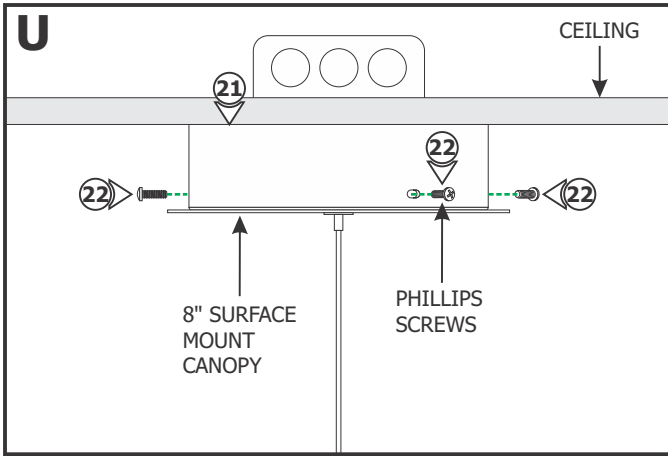

**For 8" Surface Mount Canopy:**

**21:** Place all wires and wire nut connections inside the canopy.

**22:** Align and secure the 8" Surface Mount Canopy to the mounting plate by tightening the three Phillips screws.

**Wiring Diagram**

