



1718 W. Fullerton Chicago, IL 60614
 Ph: 773.770.1195 • Fax: 773.935.5613
 www.PureEdgeLighting.com • info@PureEdgeLighting.com
 © 2016 PureEdge Lighting. All Rights Reserved.

Installation Instructions for Cirrus Channel Suspension R1 with 2" Square or Round Canopy

CSR1-2S_ _

CSR1-2R_ _

IMPORTANT INFORMATION

- This product is suitable for indoor locations.
- This instruction shows a typical installation.
- It is recommended more than one person to assist in this installation.

SAVE THESE INSTRUCTIONS!



Section One: Adjusting Cable Position

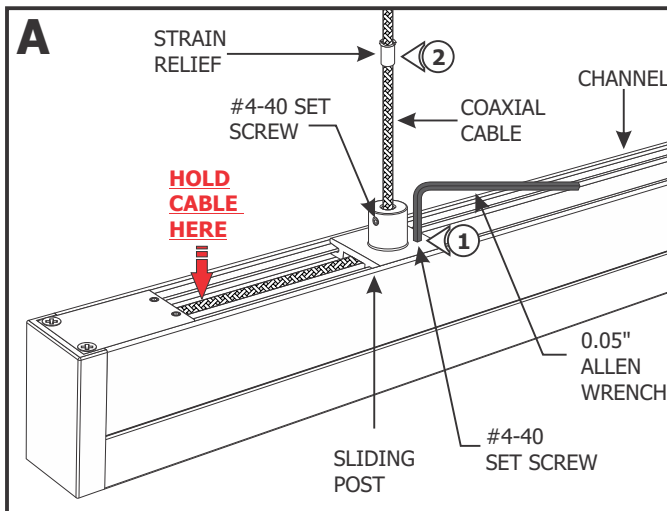

WARNING: To avoid damaging the coaxial cable electrical connection, make sure that the end of the coaxial cable coming out of the fixture is held with thumb before relocating sliding posts.

- 1: Loosen (**DO NOT REMOVE**) the #4-40 set screw on the sliding post bushing and bed with a 0.05" Allen wrench.
- 2: Slide the strain relief tube out of the sliding post using a pair of needle-nose pliers.

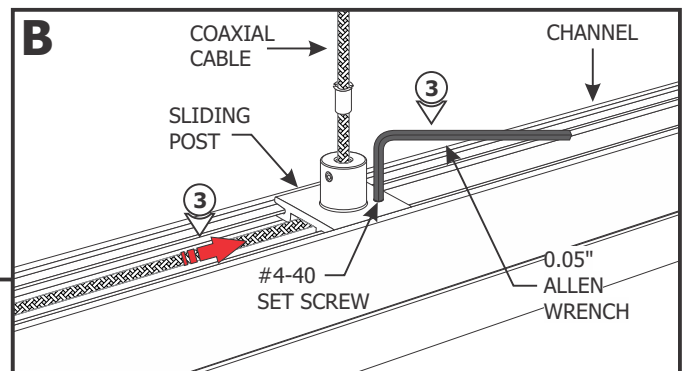

- 3: Carefully move the sliding post to the predetermined location on channel and tighten the #4-40 set screw on the sliding post bed with the 0.05" Allen wrench.

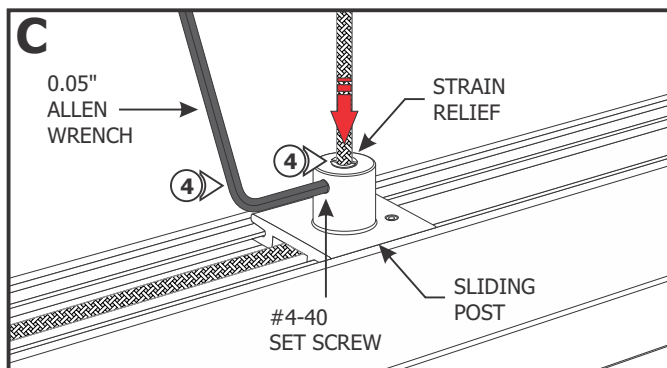

CAUTION! Tightening the strain relief set screw **CANNOT BE REVERSED**. Only tighten the set screw **AFTER** the cable location is set properly.

- 4: Insert the strain relief tube back inside the sliding post bushing and tighten the #4-40 set screw with the 0.05" Allen wrench.

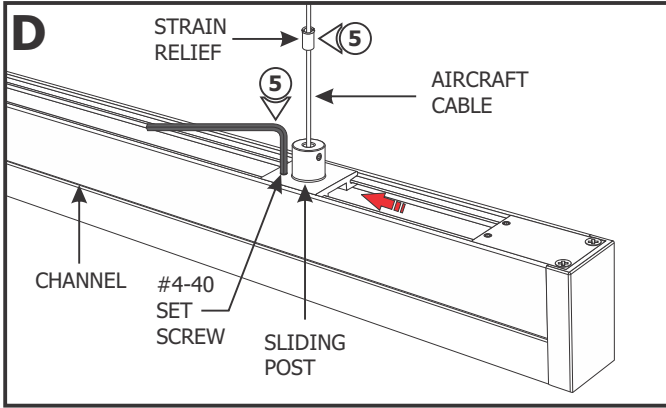

5: Repeat Steps 1 through 4 for the aircraft cables.

Section Two: Install the Standoff

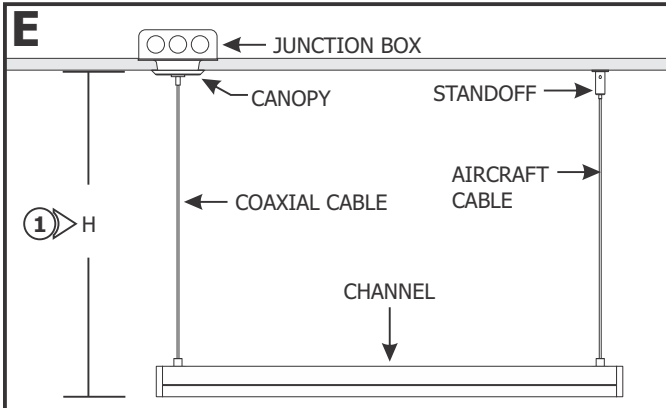

NOTE: Run the proper size wires between the 24VDC power supply to the electrical box. Refer to the instructions provided with the power supply for additional information.

NOTE: Omit Section Six if the channel is made out of a single piece.

1: Determine the fixture height (H) from the bottom of the channel to the top of the canopy.

2: Determine the fixture length (L). Measure the distance between the coaxial cable and the aircraft cable on the channel. Mark the standoff location on the ceiling from the center of the junction box.

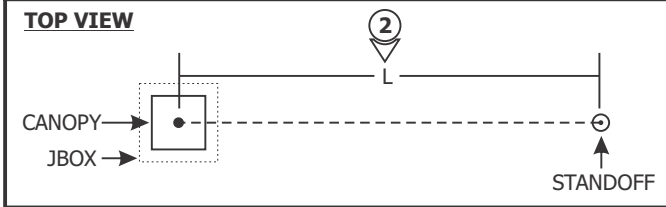

3: Tap the anchors onto the marked points up to the threaded portion with a hammer.

4: Screw in the threaded portion of the anchors with a Phillips screwdriver.

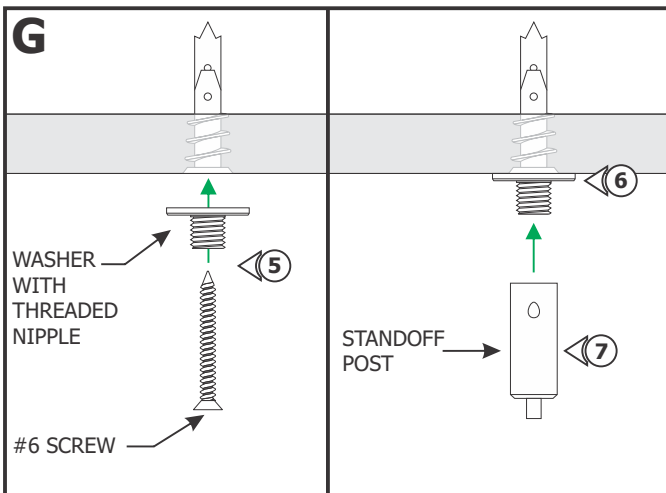
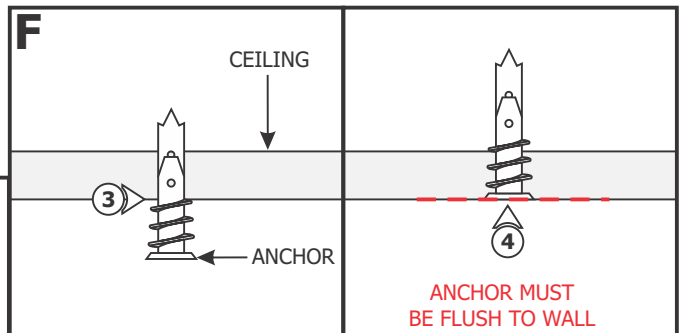

NOTE: Omit steps 5 through 10 if using support canopy. Refer to Section Three: Install the Support Canopy.

5: Feed the #6 screw through the washer with threaded nipple into the anchor.

6: Tighten the #6 screw completely into the anchor.

7: Tighten the standoff post completely onto the threaded nipple.

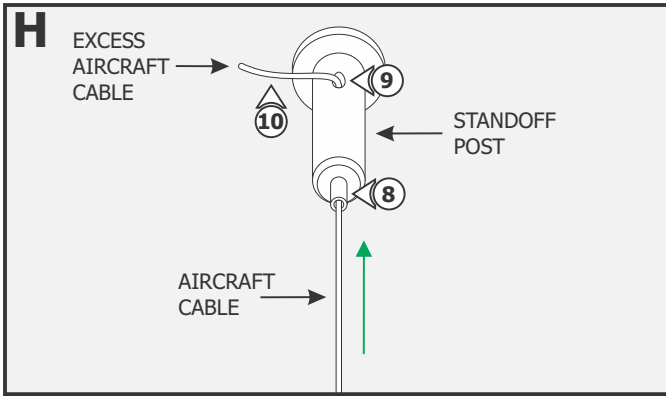

- 8:** Feed the aircraft cable coming from the channel through the standoff post.
- 9:** Adjust the fixture height by pushing the tab and pulling the aircraft cable out of the side of the standoff post. Release the tab to secure the cable in place.
- 10:** If necessary, trim excess aircraft cable using sharp cutters.

Section Three: Install the Support Canopy

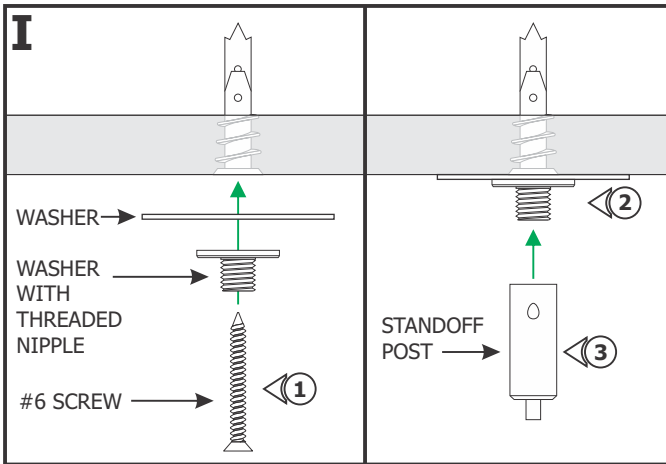

- 1:** Feed the #6 screw through the washer with threaded nipple and 2" washer respectively into the anchor.
- 2:** Tighten the #6 screw completely into the anchor.
- 3:** Tighten the standoff post completely onto the threaded nipple.

- 4:** Place the canopy over the standoff post and magnetically attach the canopy to the washer.

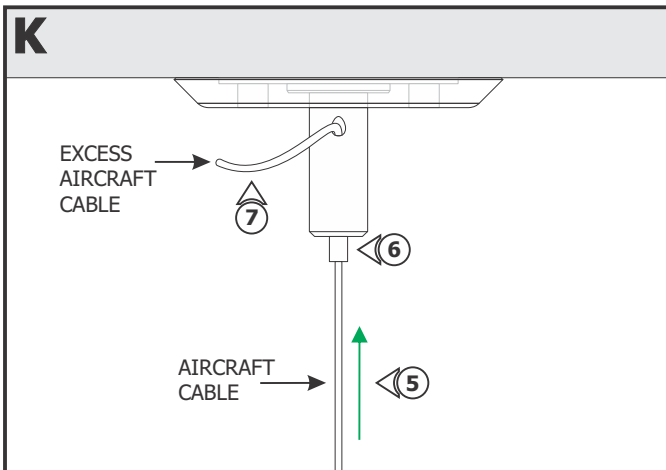
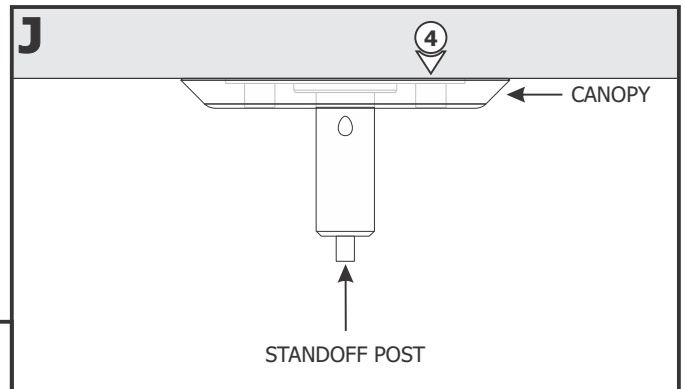

- 5:** Feed the aircraft cable coming from the channel through the standoff post.
- 6:** Adjust the fixture height by pushing the tab and pulling the aircraft cable out of the side of the standoff post. Release the tab to secure the cable in place.
- 7:** If necessary, trim excess aircraft cable using sharp cutters.

Section Four: Install the 2" Plaster Ring

For New Construction

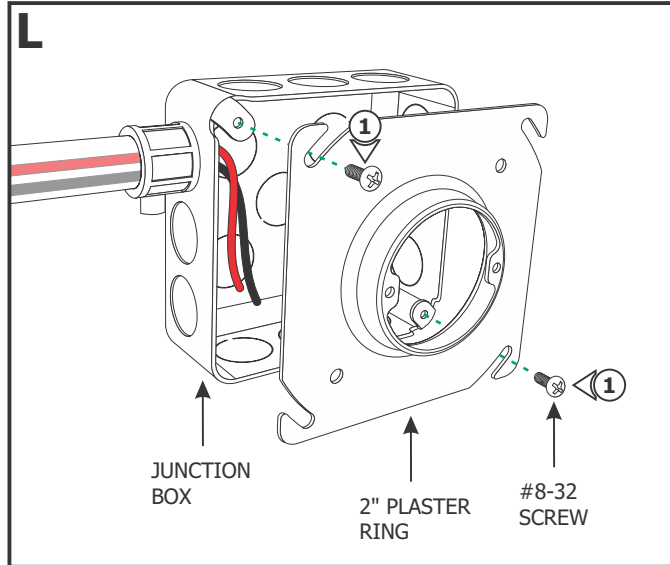

NOTE: Junction box must be mounted to allow clearance of 1/2" between the face of the junction box and the drywall surface.

NOTE: Ensure that the remote 24VDC power supply wires are present inside the junction box before continuing. Refer to the installation instructions provided with power supply.

1: Install the 2" plaster ring to the junction box using two #8-32 screws.

2: Use a circular saw to cut out the drywall section where the plaster ring is located.

3: Install the drywall. If necessary plaster, and finish the drywall.

4: Complete the installation by following the steps in Section Five.

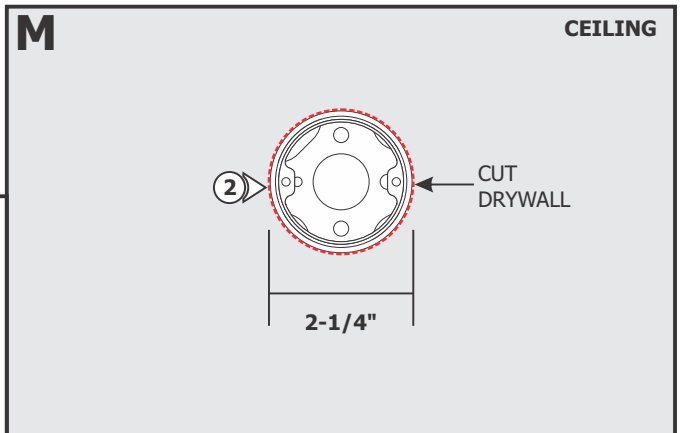

For Remodeling

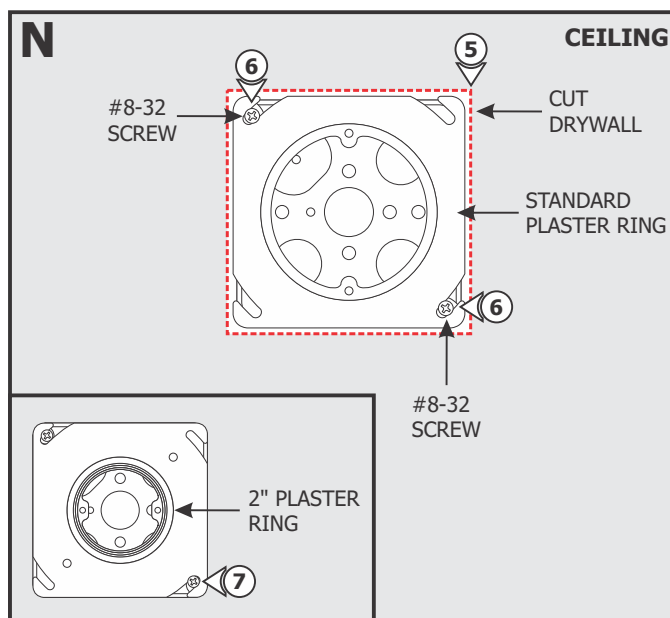

5: Cut away the drywall where the junction box is located.

6: Uninstall the existing plaster ring by removing the #8-32 screws.

7: Install the 2" Plaster Ring to the junction box using two #8-32 screws.

8: Plaster and finish around the junction box opening.

9: Complete the installation by following the steps in Section Five.

Section Five: Power the Fixture

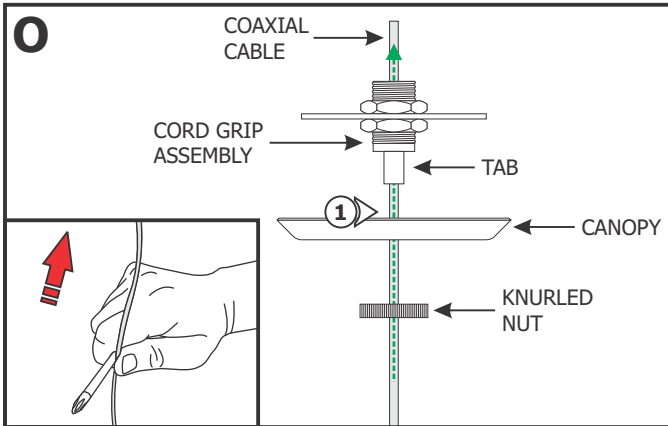

1: Feed the coaxial cable through the knurled nut, 2" canopy and cord grip assembly respectively.

NOTE: If cable is curled or kinked, straighten by holding between the shaft of a screwdriver and thumb and pulling the cable through (see inset).



NOTE: Scan the QR Code to watch the video clip of the following steps or visit http://www.edgelighting.com/videos/cxc_connector/

2: Use the 18AWG hole of the wire stripper to remove 1-3/8" of the outer insulation to expose the braided wire.

3: Use the 18AWG hole of the wire stripper to remove 1" of the braided wire making sure not to nick the inner wire insulation.

4: Use the 20AWG hole of the wire stripper to remove 1/8" of the inner insulated wire.

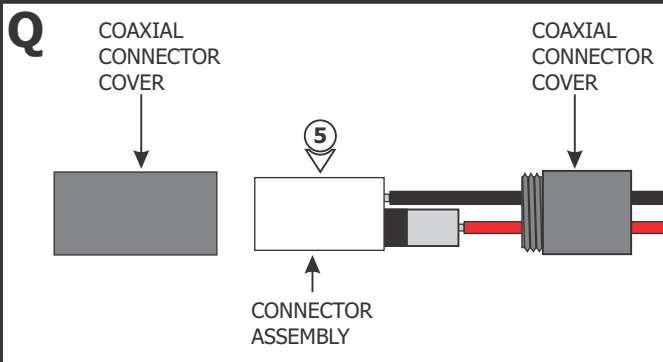
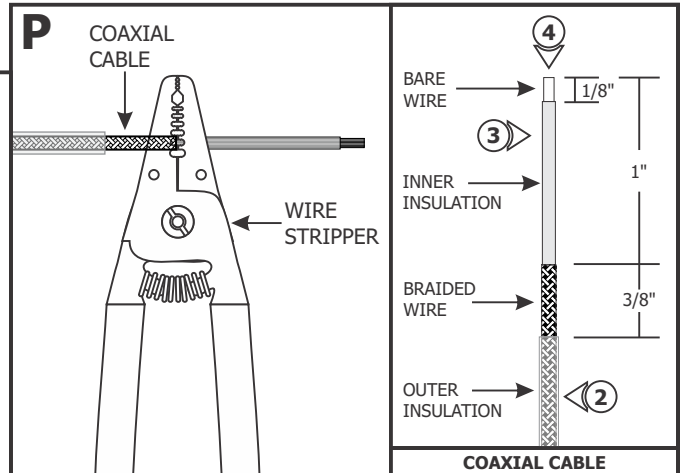

5: Unscrew the coaxial connector covers and remove from the connector assembly.

6: Using the provided 1.5mm Allen wrench, remove the M3 set screw from the coaxial connector assembly.

7: Using the provided 2mm Allen wrench to loosen (**Do Not Remove**) the M4 set screw.

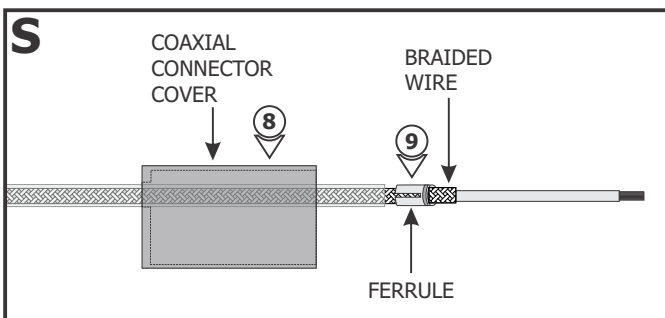
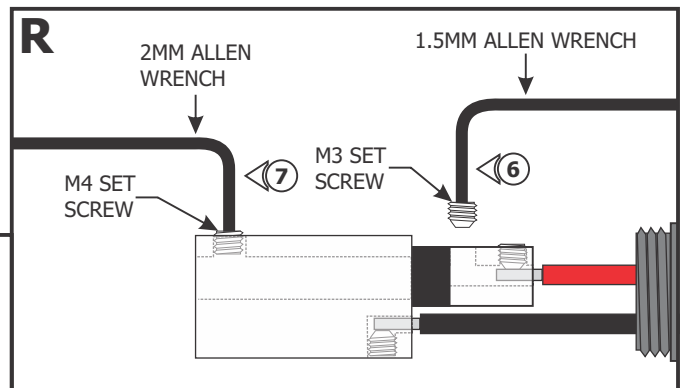

8: Slide the connector cover over the coaxial cable.

9: Place the ferrule over the 3/8" braided wire of the coaxial cable.

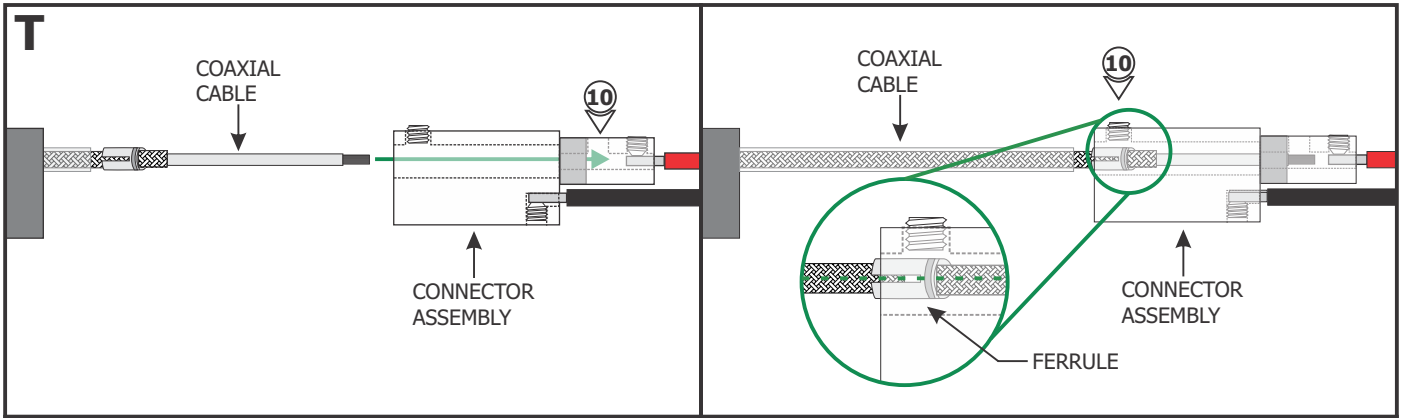

10: Insert the coaxial cable into the coaxial connector until the wires of the center conductor are visible through the M3 set screw hole.

NOTE: Ensure that the split in the ferrule is aligned 90° from the M4 set screw (see inset).

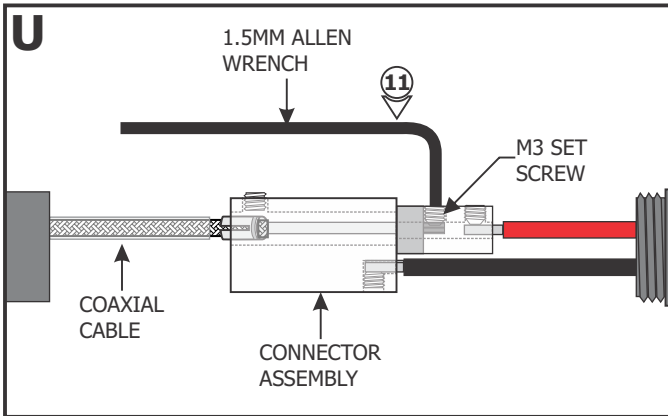

11: Use the provided 1.5mm Allen wrench to replace and securely tighten the M3 set screw.

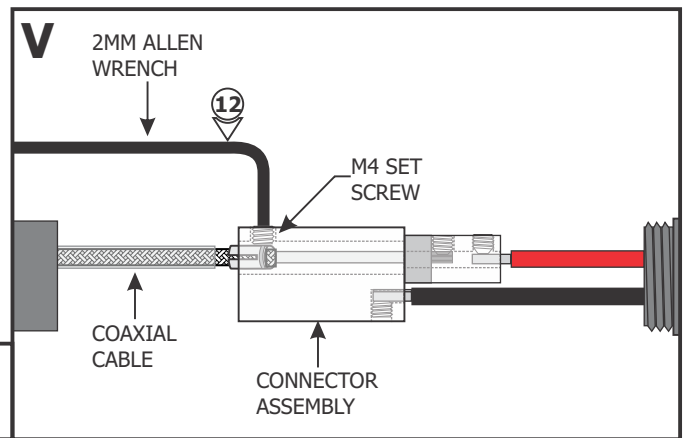

12: Use the provided 2mm Allen wrench to securely tighten the M4 set screw until it squeezes the wire ferrule tightly to the coaxial cable.

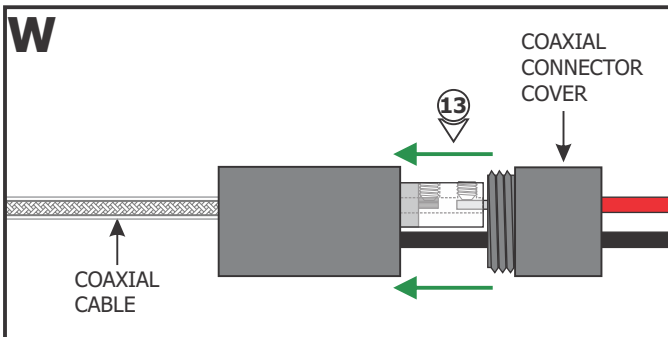

13: Replace the coaxial connector cover and tighten into place.

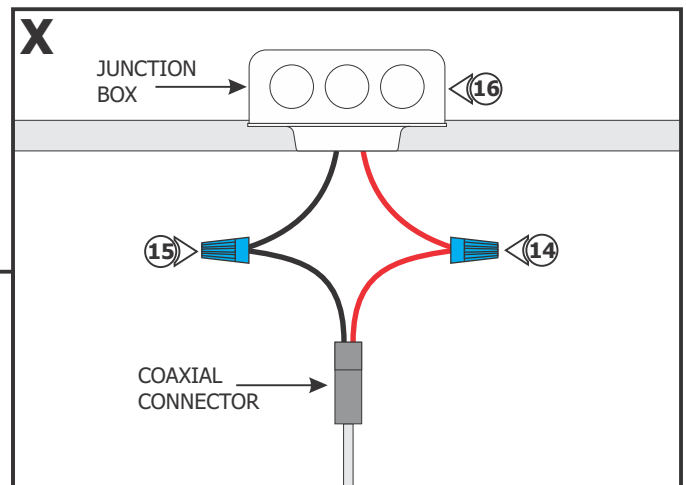

14: Connect the red wire of the coaxial connector to the +24VDC power supply wire with a wire nut.

15: Connect the black wire of the coaxial connector to the -24VDC power supply wire with a wire nut.

16: Place all connections inside the junction box.

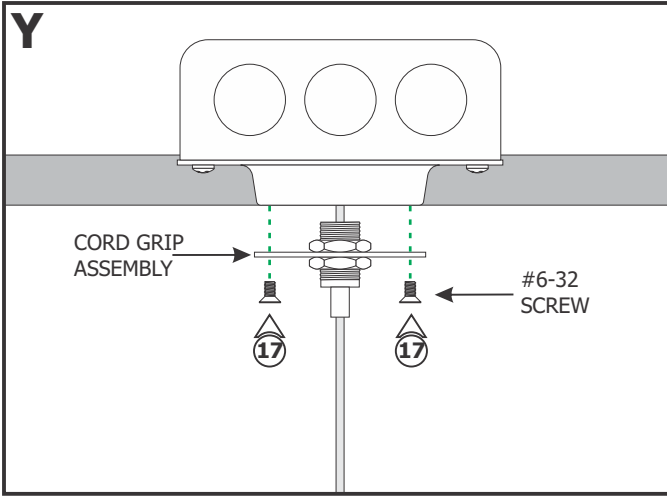

17: Mount the cord grip assembly to the 2" plaster ring using two #6-32 screws.

18: Place the canopy over the cord grip against the ceiling. Secure it in place by tightening the knurled nut to the cord grip. **Make sure the knurled cap is not cross threaded.**

19: If necessary, press the tab on the cord grip to adjust the cable height.

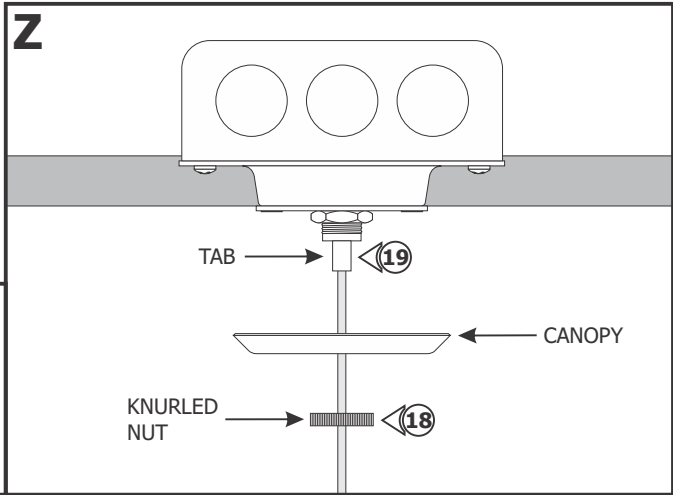

Section Six: Multiple Channel Sections

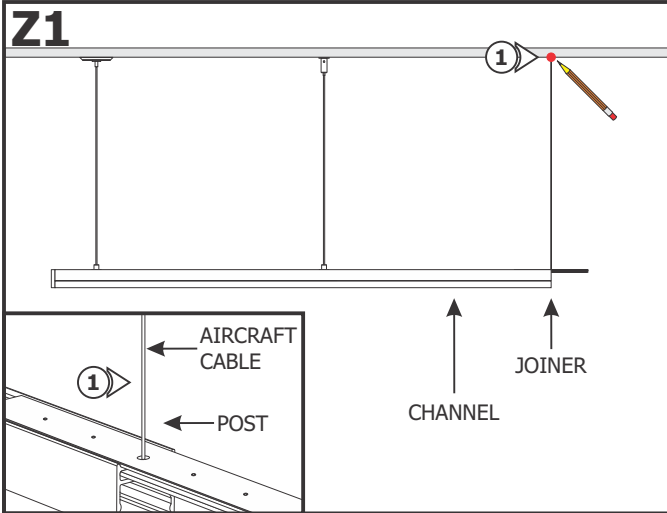

NOTE: If applicable, multiple channels must be installed one by one.

NOTE: Omit this section if the joiner did not come with the fixture depending on the overall fixture length.

NOTE: Omit Steps 1 through 9 if the joiner did not come with aircraft cable depending on the overall fixture length.

1: Lift the other end of the aircraft cable against the ceiling to mark the location of the standoff.

2: Tap the anchors onto the marked points up to the threaded portion with a hammer.

3: Screw in the threaded portion of the anchors with a Phillips screwdriver.

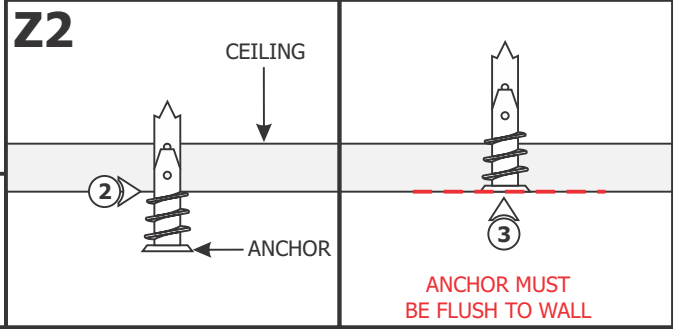

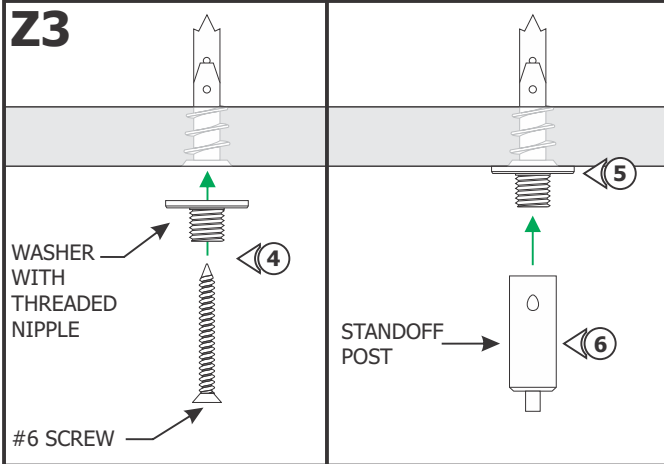
Z3

NOTE: Omit steps 4 through 9 if using support canopy. Refer to Section Three: Install the Support Canopy.

4: Feed the #6 screw through the washer with threaded nipple into the anchor.

5: Tighten the #6 screw completely into the anchor.

6: Tighten the standoff post completely onto the threaded nipple.

7: Feed the aircraft cable coming from the channel through the standoff post.

8: Adjust the fixture height by pushing the tab and pulling the aircraft cable out of the side of the standoff post. Release the tab to secure the cable in place.

9: If necessary, trim excess aircraft cable using sharp cutters.

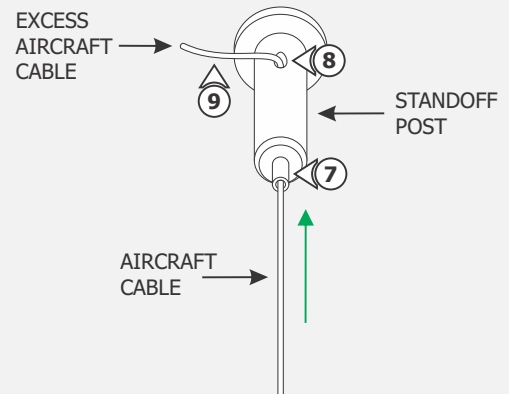
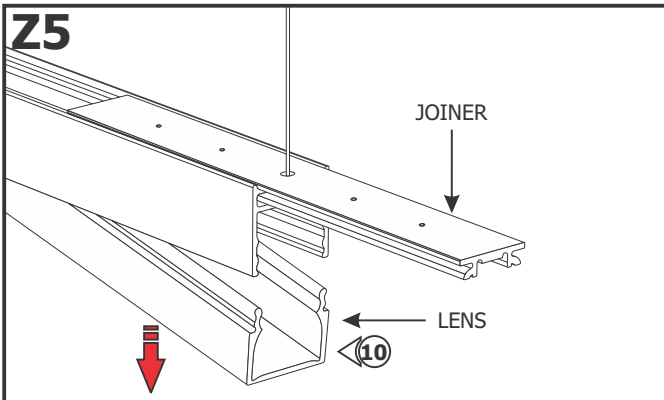
Z4**Z5**

10: Lift a section of the lens at the end of the channels where the connectors are visible. Slide the channel over the joiner and ensure the male & female connectors mate properly.

11: Push the lens back into the channel.

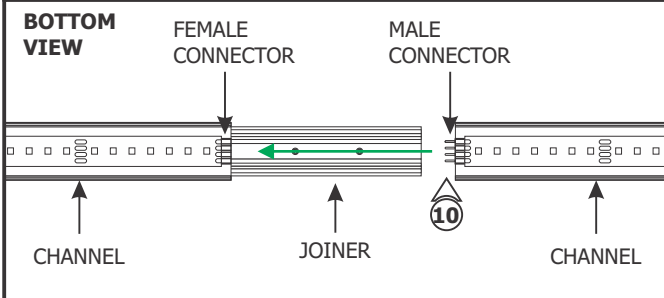
BOTTOM VIEW

12: Tighten the remaining #4-40 set screws using the 0.05" Allen wrench.

13: Refer to Sections Two or Three to install remaining standoffs and continue to connect additional channels one at a time until the fixture is complete.

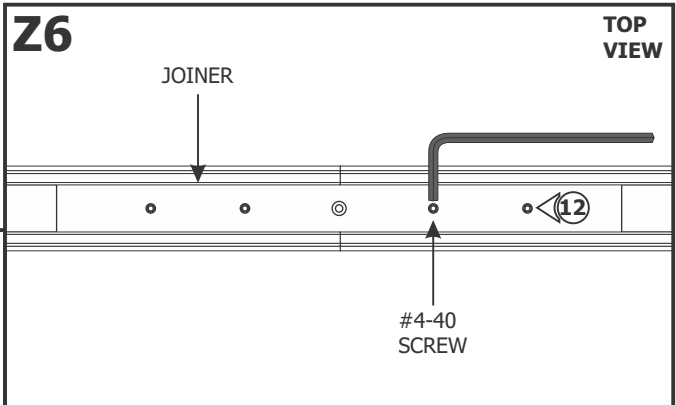
Z6

General ELV Wiring Diagram

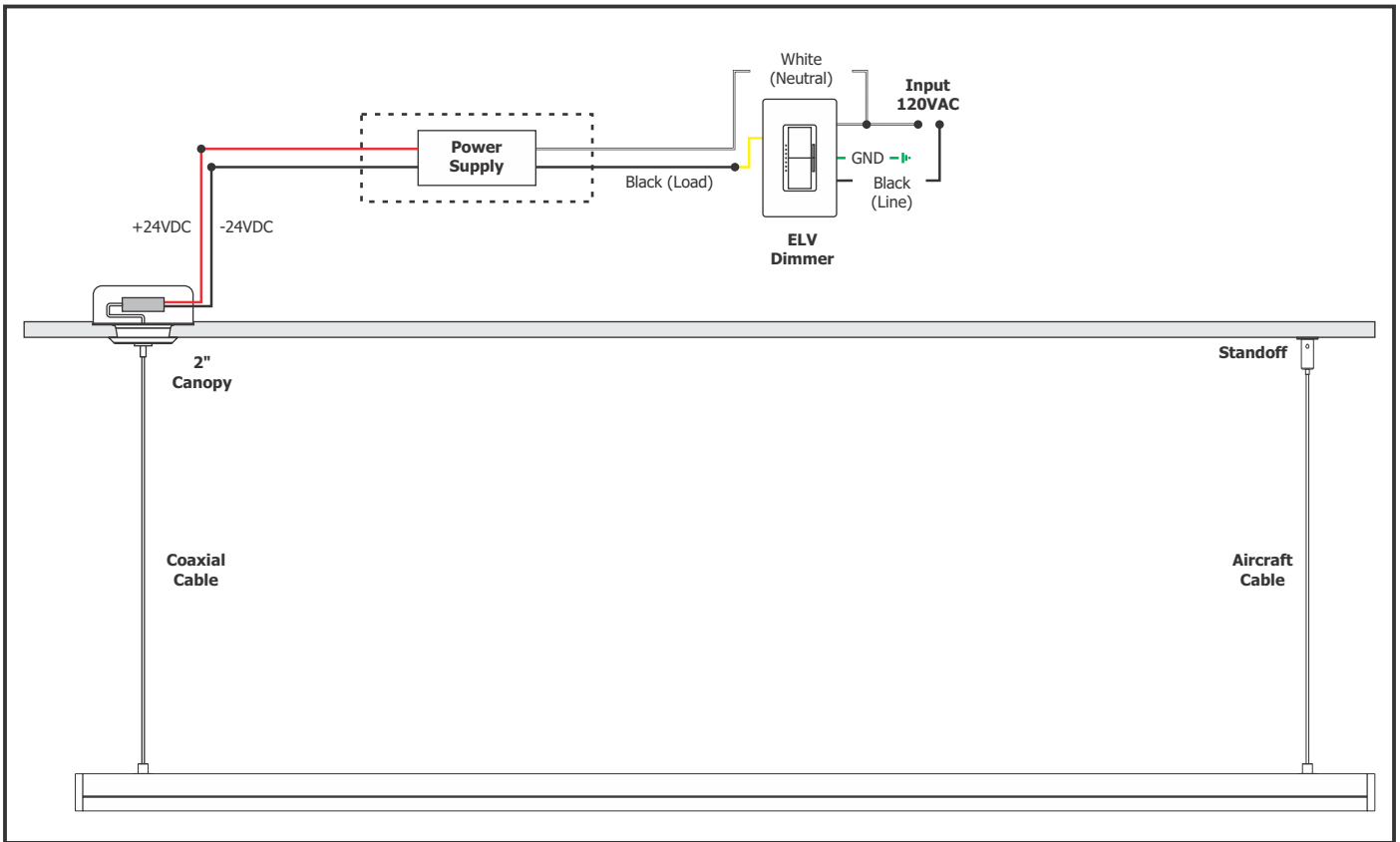

General 0-10V Wiring Diagram

