



1718 W. Fullerton Chicago, IL 60614
 Ph: 773.770.1195 • Fax: 773.935.5613
 www.PureEdgeLighting.com • info@PureEdgeLighting.com
 © 2016 PureEdge Lighting. All Rights Reserved.

Installation Instructions for Cirrus MIYO Square and Rectangle LED Suspension with Lit Corners - Center Feed, Remote Power Tunable White

CSD_-SQ-C_-

CSD_-RE-C_-

IMPORTANT INFORMATION

- This product is suitable for indoor locations.
- This instruction shows a typical installation.
- Before beginning any electrical work, ensure that power to the junction box is turned off.

SAVE THESE INSTRUCTIONS!

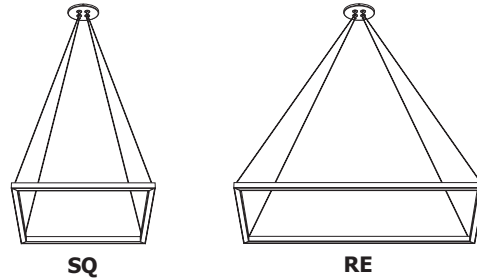

Section One: 4" Flush Canopy

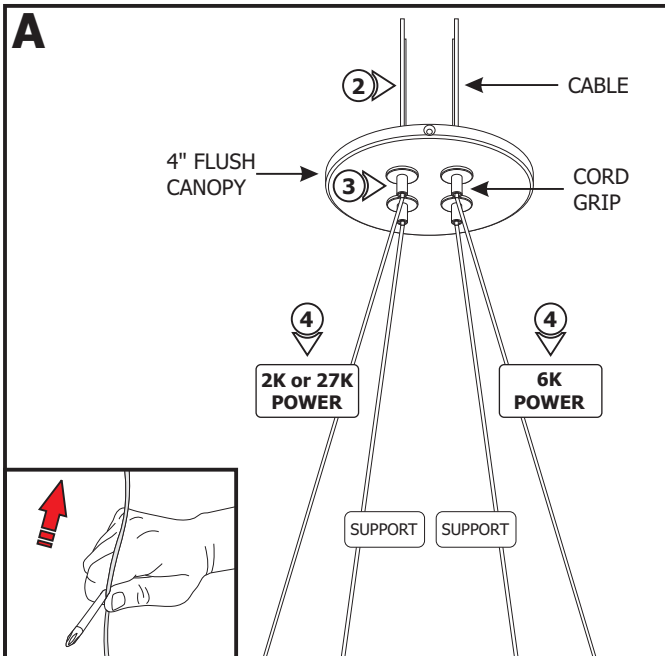

NOTE: Cord grips hold the fixture weight only. **DO NOT** pull on the fixture during installation or cleaning which may cause the **power wires to nick and short**.

NOTE: If the wire is curled or kinked, straighten by holding between the shaft of the screwdriver and thumb and pulling the wire through (see inset).

- 1: Determine the fixture height from the bottom of the channel to the top of the canopy.
- 2: Push each cable through the cord grips on the canopy.
- 3: Adjust the fixture height by pushing the cord grip tab to slide the fixture up and down. Release the cord grip tab to lock the cable in place.
- 4: Identify the **power** cables which are marked with "**POWER**" labels.

NOTE: The wires with "**SUPPORT**" labels are for support only. **DO NOT** use the support wires for power.

Section Two: Install the Coaxial Connector

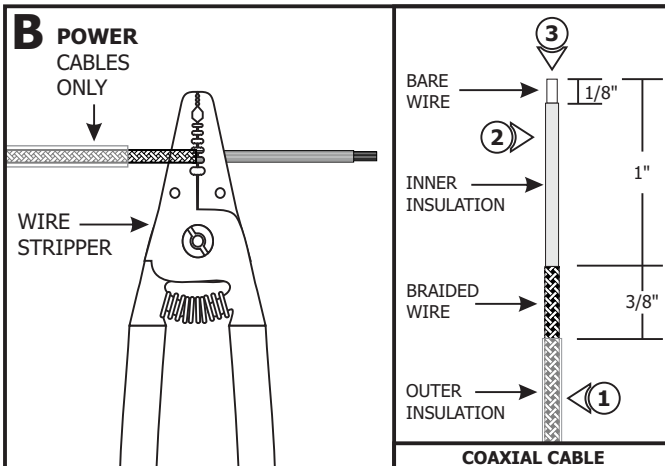

NOTE: Scan the QR Code to watch the video clip of the following steps or visit www.PureEdgeLighting.com/video_feed/installation_cxc_connector

NOTE: Steps 1 through 12 are for the **POWER** cables only.

- 1: Use the 18AWG hole of the wire stripper to remove 1-3/8" of the outer insulation to expose the braided wire.
- 2: Use the 18AWG hole of the wire stripper to remove 1" of the braided wire making sure not to nick the inner wire insulation.
- 3: Use the 20AWG hole of the wire stripper to remove 1/8" of the inner insulated wire.

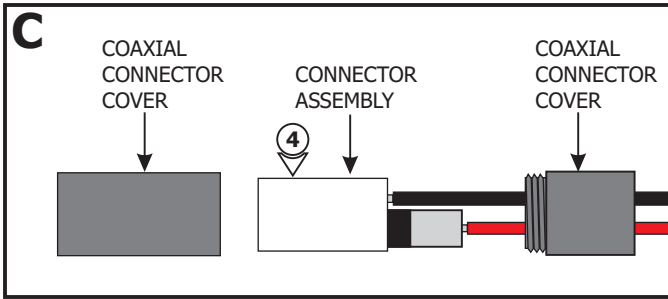

4: Unscrew the coaxial connector covers and remove from the connector assembly.

5: Using the provided 1.5mm Allen wrench, remove the M3 set screw from the coaxial connector assembly.

6: Using the provided 2mm Allen wrench to loosen (do not remove) the M4 set screw.

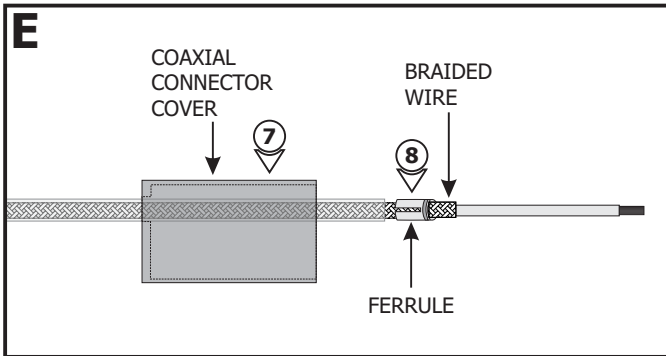
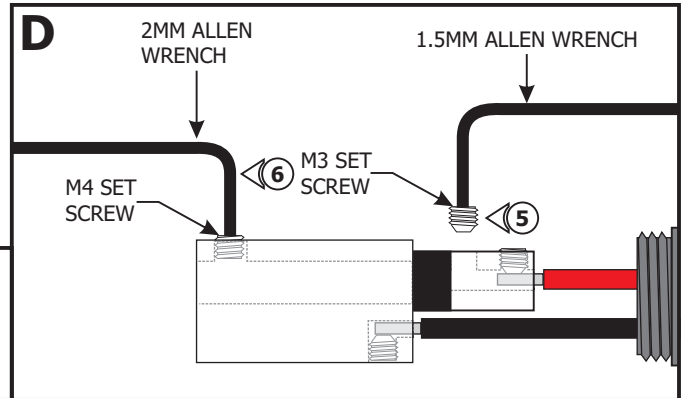

7: Slide the connector cover over the coaxial cable.

8: Place the ferrule over the 3/8" braided wire of the coaxial cable.

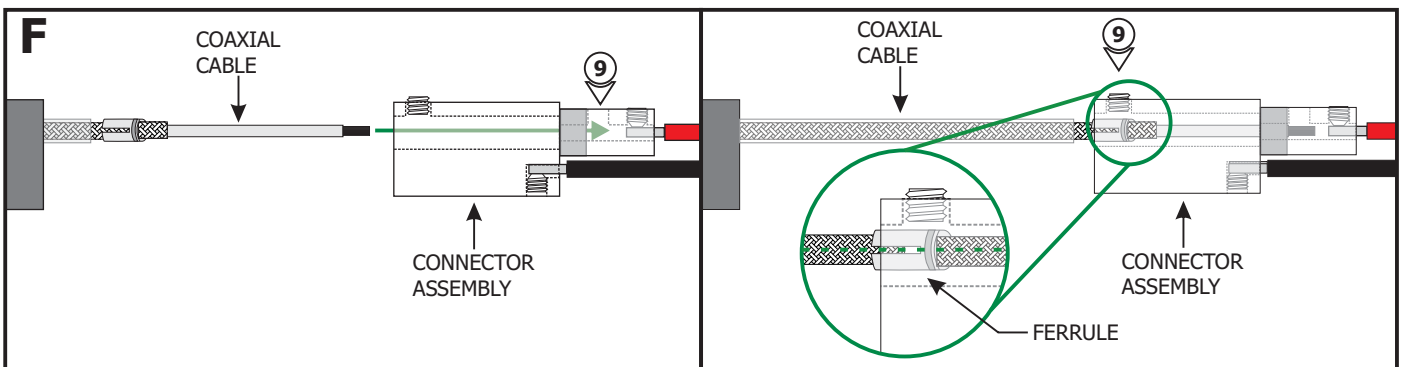

9: Insert the coaxial cable into the coaxial connector until the wires of the center conductor are visible through the M3 set screw hole.

NOTE: Ensure that the split in the ferrule is aligned 90° from the M4 set screw (see inset).

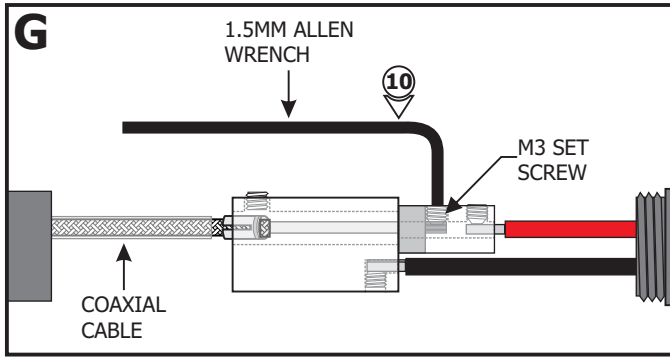

10: Use the provided 1.5mm Allen wrench to replace and securely tighten the M3 set screw.

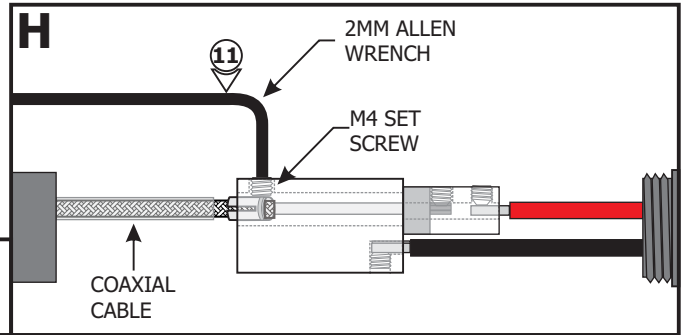

11: Use the provided 2mm Allen wrench to securely tighten the M4 set screw until it squeezes the wire ferrule tightly to the coaxial cable.

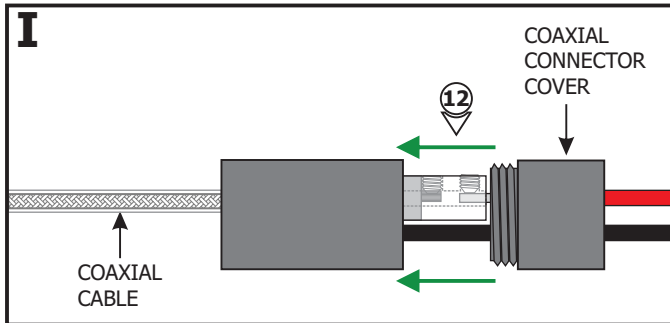

12: Replace the coaxial connector cover and tighten into place.

13: Repeat steps 1 through 12 to connect the other coaxial connector to the other power cable.

Section Three: Power the Fixture

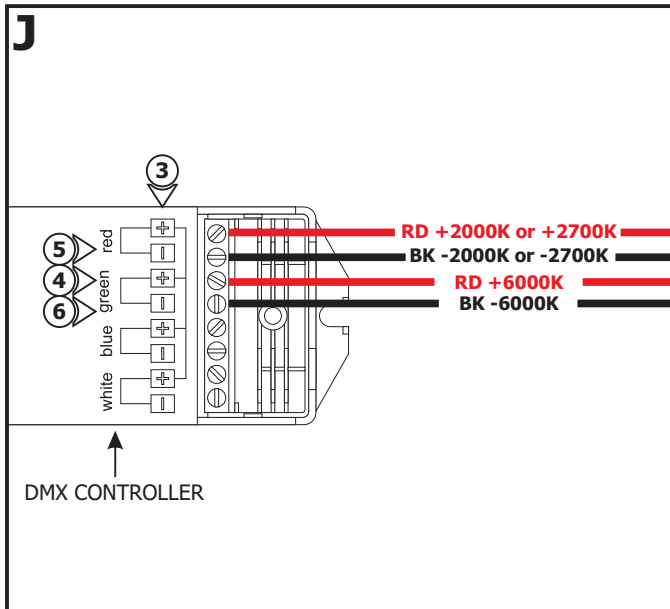

NOTE: Omit steps 1 through 6 if using two channel controls. Refer to wiring diagram on page 6.

1: Use the "Low Voltage Wire Size Chart" below to determine proper wire size connecting to the DMX controller terminals.

2: Run the proper size red and black wires from the power supply enclosure to the fixture.

3: Connect the red wire for +2000K or +2700K to the red "+" DMX terminal and tighten the screw.

4: Connect the red wire for +6000K to the green "+" DMX terminal and tighten the screw.

5: Connect the black wire for -2000K or -2700K to the red "-" DMX terminal and tighten the screw.

6: Connect the black wire for -6000K to the green "-" DMX terminal and tighten the screw.

100W, 24VAC LOW VOLTAGE WIRE SIZE CHART					
3% VOLTAGE DROP	WIRE LENGTH IN FT	UP TO 31FT	32FT-49FT	50FT-81FT	82FT-124FT
	WIRE SIZE	14 AWG	12 AWG	10 AWG	8 AWG
	VOLTAGE AT END OF THE WIRE	23.28 VAC	23.29 VAC	23.28 VAC	23.28 VAC

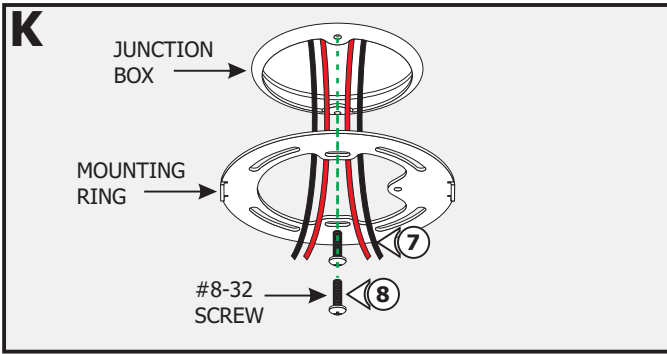

NOTE: Ensure remote power supply wires are present in the junction box. Refer to instructions provided with the power supply.

7: Feed the wires coming from the power supply through the center hole of the mounting ring.

8: Mount the ring to the junction box holes with two #8-32 screws.

NOTE: Omit steps 9 through 11 if using two channel controls. Refer to wiring diagram on page 6.

9: Connect the red and black coaxial connector wires to the red and black power supply wires for 2000K (2700K) respectively using wire nuts.

10: Repeat step 9 for the other coaxial connector and remaining power supply wires for connecting 6000K.

11: Refer to wiring diagram on page 5.

CAUTION: Test the fixture before removing the labels.

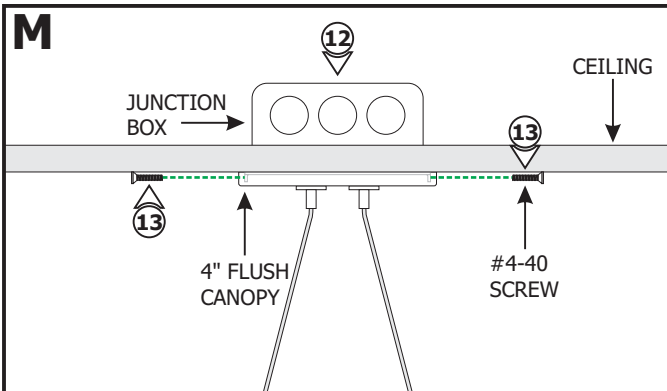
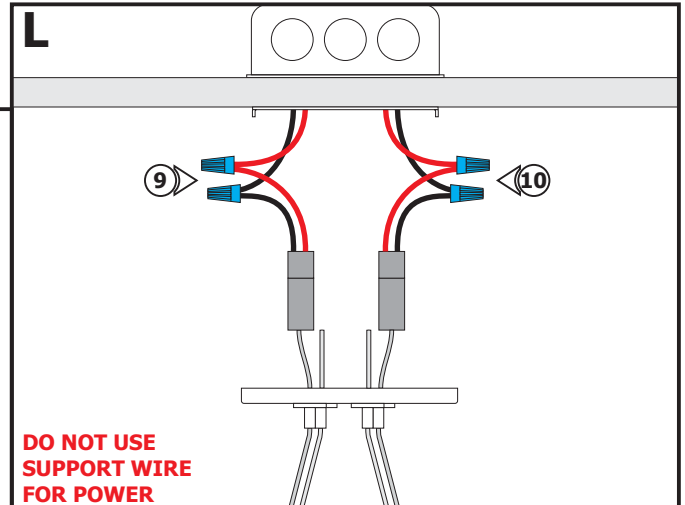

12: Place all wires and wire nut connections inside the junction box.

13: Align the canopy with the mounting ring and secure it with the two #4-40 screws using a 1/16" Allen wrench.

General Wiring Diagrams

Using LED Power Supply with CDP, CTP, or CDMX Control

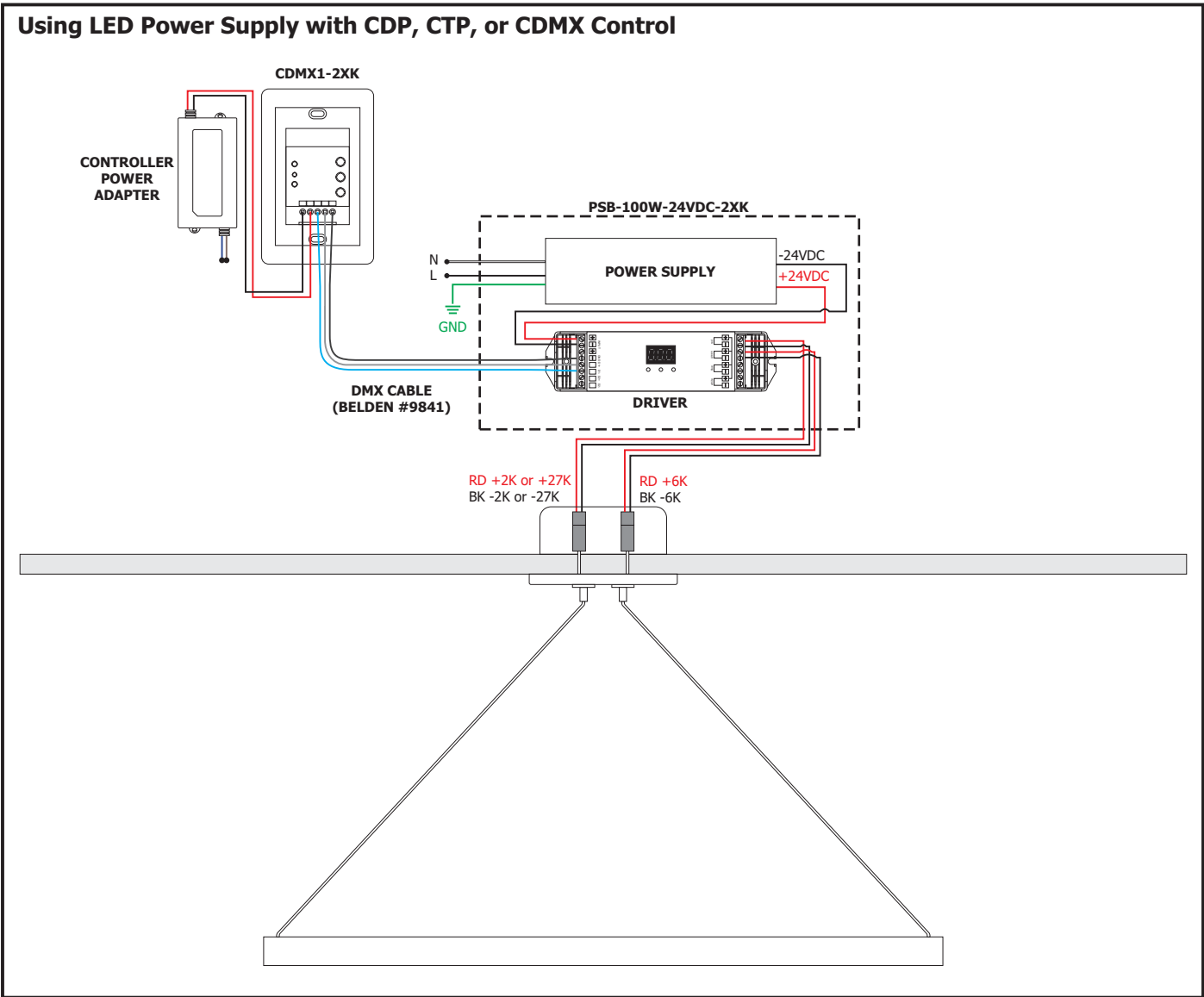

Using LED Power Supply with two Channel Controls, for Intensity and Color Temperature

