

Installation Instructions for **Bubble Ball 14 and 17 Linear Canopy**

IMPORTANT SAFETY INSTRUCTIONS

To reduce the risk of fire, electrical shock, exposure to excessive UV radiation, or injury to persons:

- Use this fixture indoors only.
- Do not look directly at the lamp while the fixture is on.
- **RISK OF FIRE:** Use only the type of lamp and maximum wattage indicated in this instruction manual.
- Never cover the halogen lamp with anything other than a lamp shield provided by Edge Lighting and never place flammable material close to the fixture.
- Never turn the fixture on and off by connecting and disconnecting the halogen lamp.
- Do not touch the fixture head, shade or lamp shield while the fixture is on. These surfaces may be **VERY HOT**.
- Do not touch lamp at anytime. Use a soft cloth instead as oil from skin may damage lamp.
- It is normal for a new halogen lamp to produce minor smoke when first turned on.
- Do not operate the luminaire with a missing or damaged shield.
- Turn power off and allow to cool before replacing lamp.

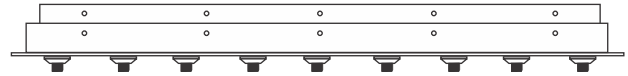

IMPORTANT INFORMATION

- This instruction shows a typical installation.

SAVE THESE INSTRUCTIONS!

Install the Canopy

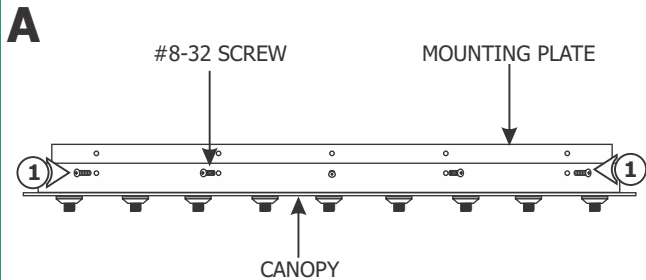

- 1:** Remove the fourteen #8-32 screws around the canopy to remove the mounting plate.

NOTE: It is recommended that a person to hold the mounting plate while the electrician installs it.

- 2:** Feed the power wires through mounting plate center hole.
- 3:** Align the mounting plate slots with the electrical box holes and secure it to the electrical box holes with the provided two #8-32 screws.

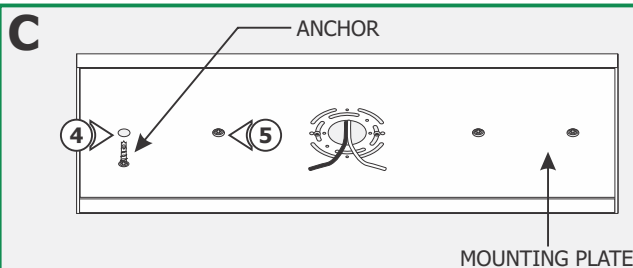
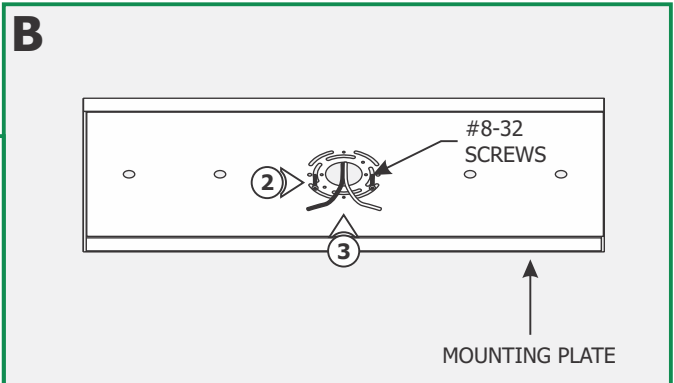

- 4:** Tap the anchors through the mounting plate holes onto the marked point up to the threaded portion with a hammer.
- 5:** Screw in the threaded portion of the anchors with a Phillips screwdriver.

NOTE: All 4 anchors must be installed to balance the pendants weight.

D

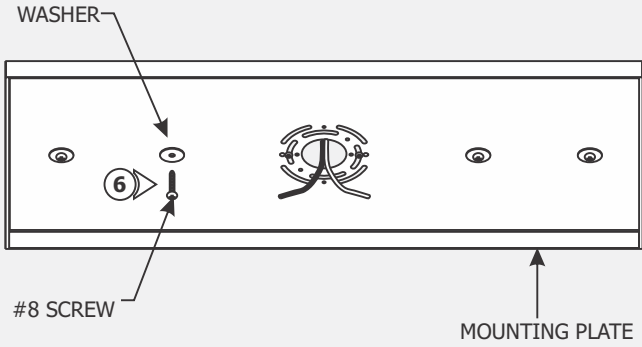

6: Secure the mounting plate to the anchors with the provided #8 screws and washers.

7: Make sure that the mounting plate is grounded in accordance with local electrical codes.

NOTE: Make sure a person holds the Fast Jack canopy while the electrician connects the wires and completes the installation.

8: Connect the Fast Jack white canopy wire to the neutral power wire with a wire nut.

9: Connect the Fast Jack black canopy wire to the hot power wire with a wire nut.

E

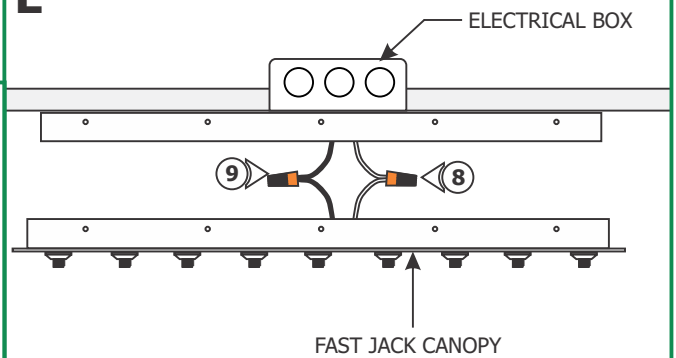

Installing Fixture on Canopy

F

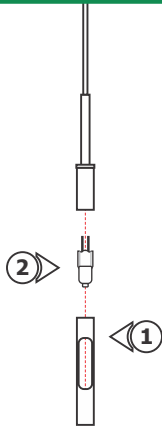

1: Unscrew the bottom portion of the fixture to attach lamp

2: Insert lamp into 2-pronged socket, and re-attach the bottom portion of the fixture

NOTE: Do not loosen or otherwise modify the power cable set screw. This will cause damage to the fixture.

3: Feed the coaxial cable through the glass shade, and rest the glass shade over the socket assembly.

G

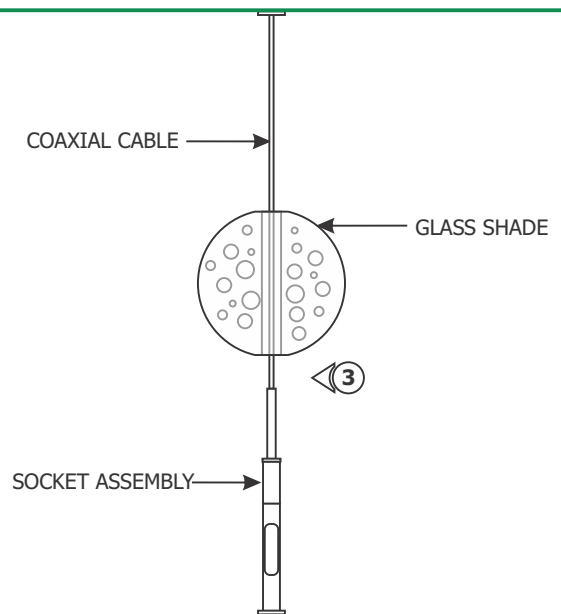

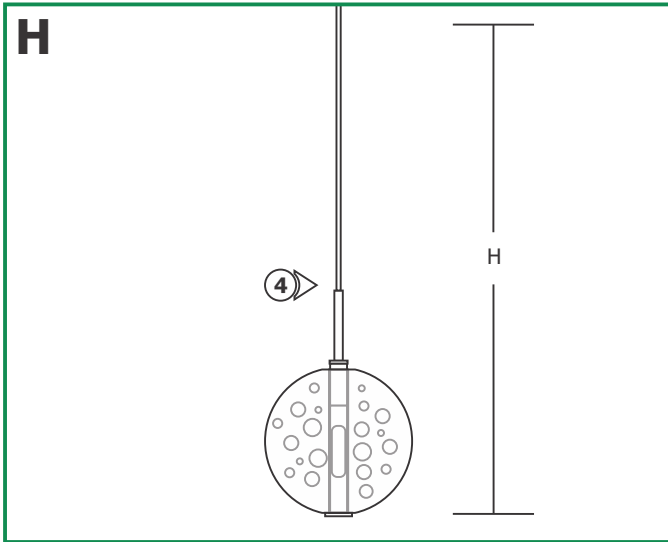

4: Cut the coaxial cable to the desired height (H) with a sharp cutter. The overall fixture height is measured from the bottom of the glass shade to the end of the coaxial cable.

5: Loosen the two M4 set screw on base of the coaxial fixture connector with the 2mm Allen wrench provided. **Do not remove these set screws.**

6: Remove the M3 set screw on tip of the connector with the 1.5mm Allen wrench provided.

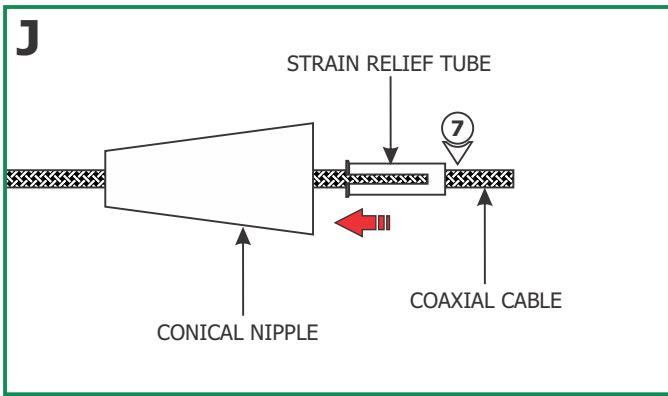
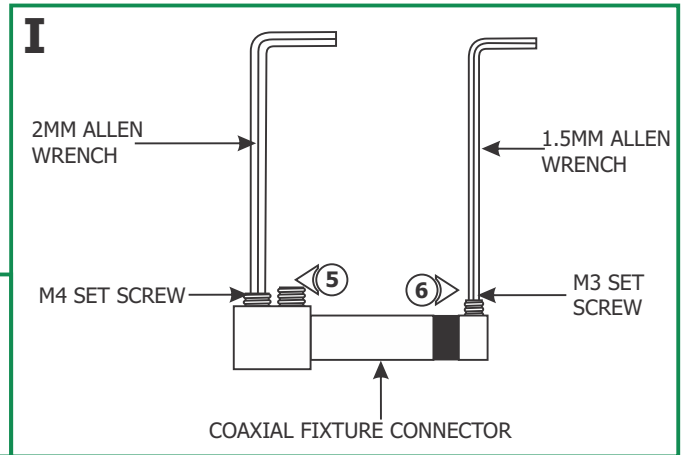

7: Feed the coaxial cable through the conical nipple and flared side of the strain relief tube. Slide the conical nipple and strain relief tube down the coaxial cable.

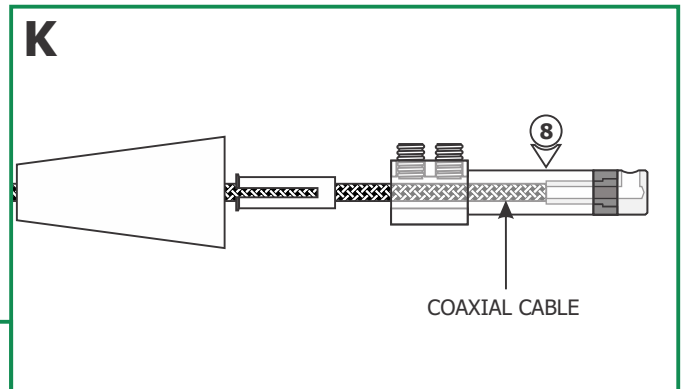

8: Feed the coaxial cable into the coaxial fixture connector. The coaxial cable will come to a stop point.

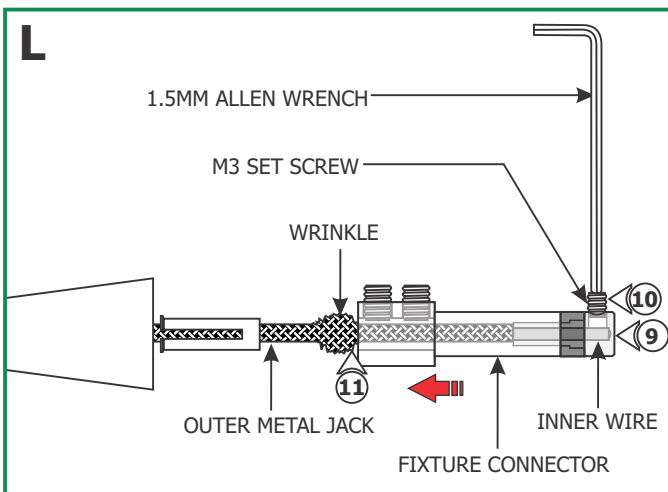

9: Keep feeding the coaxial cable in until the inner wire is visible in the screw hole of the fixture connector tip. The outer metal jacket will start to wrinkle.

10: Hold the fixture connector in place. Replace and tighten the M3 set screw on fixture connector tip with the 1.5mm Allen wrench.

11: Pull down the outer metal jacket to smooth the wrinkles.

M

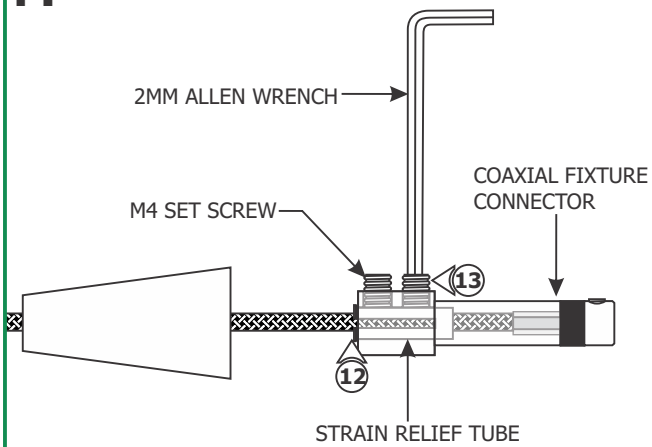

12: Push the strain relief tube completely into the coaxial fixture connector. Make sure the slot on the strain relief tube is not inline with the M4 set screw.

13: Tighten the two M4 set screws with the 2mm Allen wrench.

CAUTION: Maximum load of each port is **20 watt**. Use only fixtures that are rated 20 Watt or less, or relamp each fixture with a **Maximum 20 watt** lamp.

14: Use fingers to tighten each Fast Jack fixture connector into one Fast Jack canopy port.

N

